

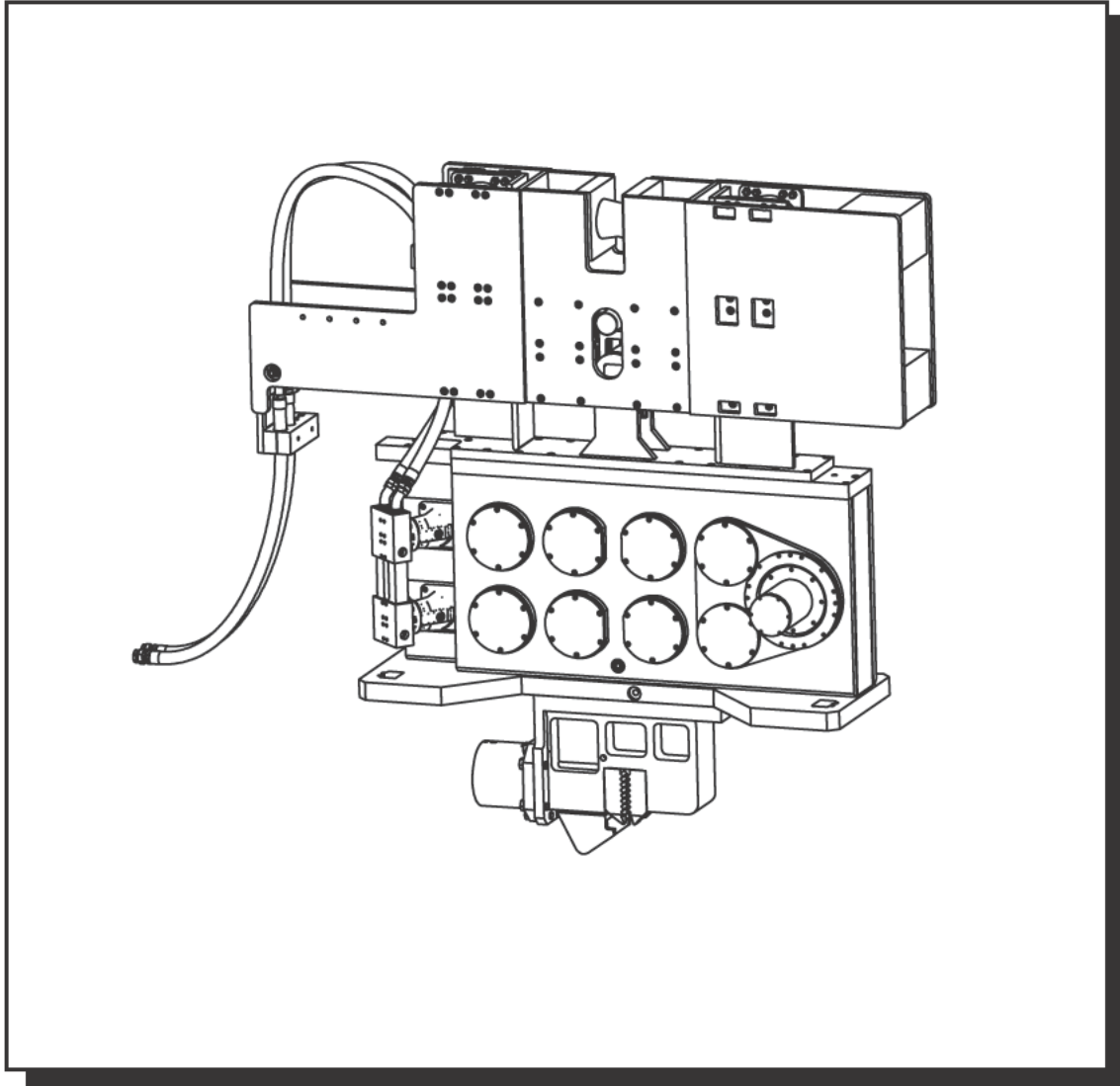

OPERATION / MAINTENANCE MANUAL

MODEL 250VM VIBRATORY DRIVER WITH MODEL 700VM POWER UNIT

7032 SOUTH 196th - KENT, WA. 98032 - (253) 872-0141 / FAX (253) 872-8710



SERIAL NUMBER:

**MODEL 250VM VIBRO
WITH MODEL 700VM POWER UNIT**

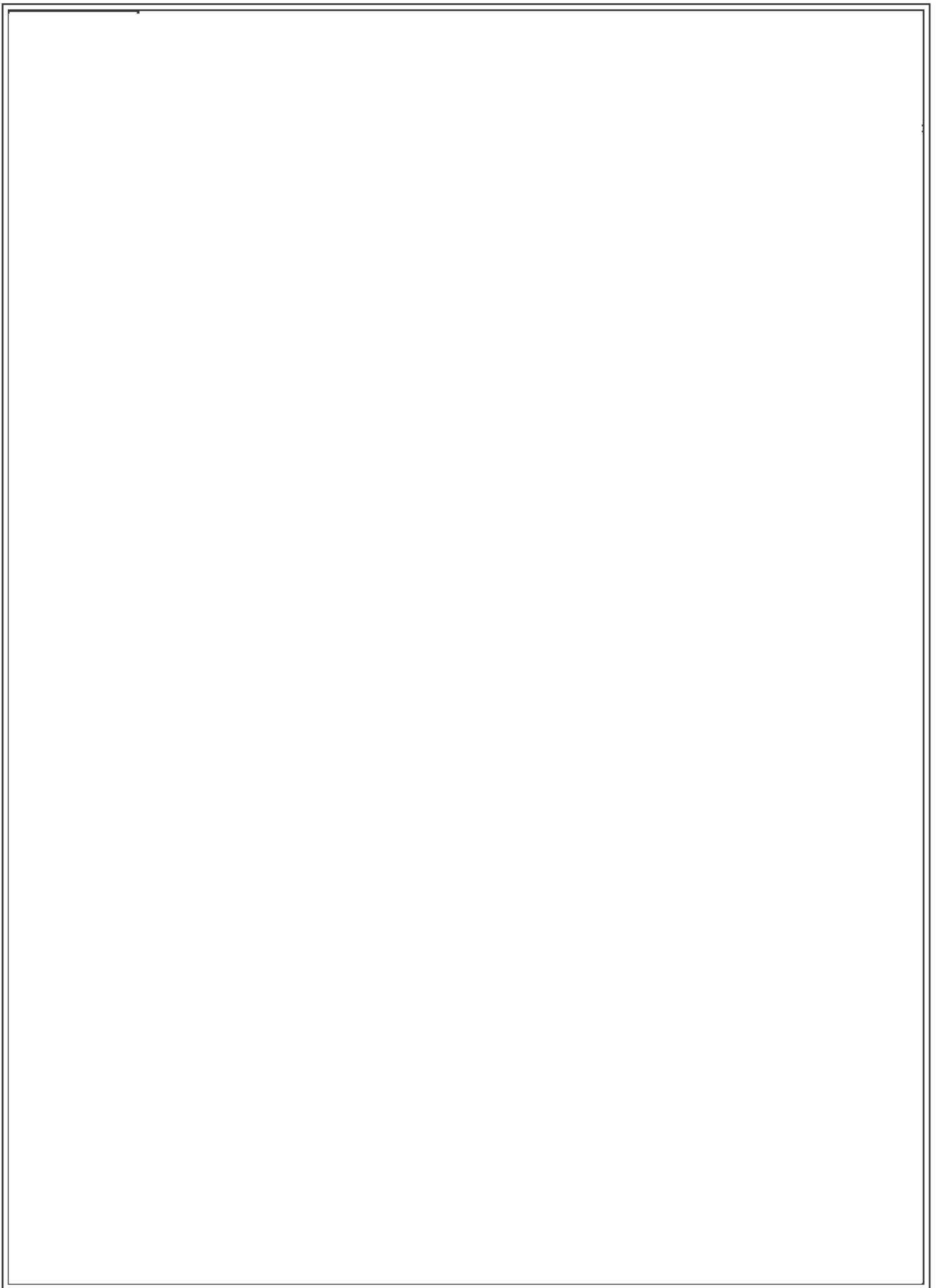



OPERATION / MAINTENANCE MANUAL

MODEL 250VM VIBRATORY DRIVER WITH MODEL 700VM POWER UNIT

7032 SOUTH 196th - KENT, WA. 98032 - (253) 872-0141 / FAX (253) 872-8710

Revision Record

Change Number	Page Number	Date	Revision Description
1	4-7 & 4-8	3-30-12	Updated verbage for Auto / Manual control
2	Sec 8	5-3-13	Added section 8



OPERATION / MAINTENANCE MANUAL

MODEL 250VM VIBRATORY DRIVER WITH MODEL 700VM POWER UNIT

7032 SOUTH 196th - KENT, WA. 98032 - (253) 872-0141 / FAX (253) 872-8710

Preface

General

This manual covers the **Model Model 250VM Vibratory Driver/Extractors and the Model 700VM Power Unit**. Most information contained in this manual is identical for all the models covered. The data provided in this manual gives the necessary information to operate and maintain APE equipment. The listed procedures are to be performed by qualified personnel who have an understanding of the equipment and who follow all safety precautions.

Guide to Using the Manual

1. Refer to the Table of Contents for the page location of applicable sections.
2. All weights and measurements in this manual are in both English and Metric units.
3. The manual will be revised as necessary to reflect current information.

Abbreviations

The following are abbreviations used within this manual.

lbs.	= Pounds	HCLW	= High Collar Lock Washer
psi.	= Pounds per Square Inch	P/N	= Part Number
hp.	= Horse Power		
gpm.	= Gallons Per Minute		
rpm.	= Revolutions Per Minute		
eng.	= Engine		
cyl.	= Cylinder		
mm.	= Millimeter		
mtg.	= Mounting		
S/N	= Serial Number		
sol.	= Solenoid		

Serial Number Locations

1. **VIBRATOR:** Above and in between the eccentric covers on both sides of the machine.
2. **POWER UNIT:** On both sides in front of reservoir near the top.



OPERATION / MAINTENANCE MANUAL

MODEL 250VM VIBRATORY DRIVER WITH MODEL 700VM POWER UNIT

7032 SOUTH 196th - KENT, WA. 98032 - (253) 872-0141 / FAX (253) 872-8710

Table of Contents

	Page
Revision Record	i
Preface	ii
Table of Contents	iii
Safety Precautions	v
Illustration List	vi
Table List	vi
Warranty	vii
I. GENERAL INFORMATION	
I-1. Machine Features	1-1
I-2. Machine Specifications	
A. Model 250VM Vibro	1-2
B. Model 700VM Power Unit	1-2
I-3. General Description of 250VM Vibro	
A. Suppressor Housing	1-4
B. The Vibrator Gearbox	1-5
C. Clamp Attachment	1-6
D. Optional Attachments	1-7
I-4. General Description of Model 700VM Power Unit	1-8
II. MAJOR COMPONENT DEFINITION	
II-1. 250VM Assembly Identification	2-2
II-2. Suppressor Identification	2-4
II-3. Gearbox Identification	2-6
II-4. 250VM Phase Shifter Identification	2-8
II-5. Model 200 Clamp Identification	2-10
II-6. Hose Identification	2-12
II-7. Model 700VM Power Unit Skid Identification	2-14
II-9. Quick Disconnect Coupling Identification	2-15
II-10. Tool Set Identification	2-16
II-11. Caisson Clamp Identification	2-17
II-11. Control Panel and Parts	2-18
II-12. Control Pendant and Parts	2-22
III. LOADING AND UNLOADING	
III-1. Model 250VM Vibratory Hammer	3-1
III-2. Model 700VM Power Unit	3-1
III-3. What to do if damaged during shipment	3-1
IV. PREPARATION AND OPERATION	
IV-1. Rigging of Vibratory Hammer	4-1
IV-2. Installing the Clamp Attachment	4-1
IV-3. Plumbing the Vibro Hoses to the Power Unit	4-2
IV-4. Filling Vibrator Pressure Hoses	4-3
IV-5. Bleeding Clamp Attachment Hydraulic Hoses	4-3
IV-6. Precautions and Rules for Operation	4-4
IV-7. Relief Valve Settings Prior to Operation - Model 700VM	4-5
IV-8. Shut-down Procedures	4-7
IV-9. Operation of the Control Pendant	4-8
IV-10. Normal Steps to Operate Vibrator	4-8



OPERATION / MAINTENANCE MANUAL

MODEL 250VM VIBRATORY DRIVER WITH MODEL 700VM POWER UNIT

7032 SOUTH 196th - KENT, WA. 98032 - (253) 872-0141 / FAX (253) 872-8710

Table of Contents (Continued...)

V. MAINTENANCE

V-1. Daily Maintenance Required Prior to Operation	5-1
V-2. Checklist After Power Unit Engine Has Started	5-1
V-3. Maintenance and Adjustments: (75 Hours) (for lubrication see V-6)	5-2
V-4. Maintenance and Adjustments: (Eccentric Bearings)	5-2
V-5. Maintenance and Adjustments in Severe Conditions	5-2
V-6. Lubrication	
A. Vibratory Gearbox	5-2
B. Clamp Attachment	5-2
V-7. Power Unit	
A. Power Unit Filters, Fluid Types and Capacities	5-3
B. Hydraulic Fluid	5-4
C. Two Part Hydraulic Fluid Tank	5-4
D. Draining and Filling Hydraulic Fluid Tank	5-4
E. Changing Hydraulic Return Filter Element	5-5
F. Steps to Remove Filter Element	5-5
V-8 Pump drive	5-7

VI. TROUBLE-SHOOTING: Model 250VM Vibro	6-1
---	-----

VII. MODEL 700VM POWER UNIT

VII-1. Hydraulic Circuitry	7-1
A. Clamp Circuitry	7-1
B. Drive Circuit	7-1
C. Phase In / Out	7-1
D. Vibro High / Low Circuit	7-1
E. Hydraulic Schematic	7-2
F. Hydraulic Components - Clamp / Drill Manifold	7-3
G. Hydraulic Components - Drive Manifold	7-5
H. Hydraulic Components - Phase In / Phase Out Manifold	7-7
I. Hydraulic Components - Hose Identification and Routing	7-10
J. Hydraulic Components - Tank Detail	7-11
K-N. Hydraulic Components - Misc	7-13
O. Hydraulic Components - Pumps	7-14
VII-2. Electrical Circuitry	7-16
A. Main Circuit Breaker	7-16
B. Tachometer	7-16
C. Hourmeters	7-16
D. Engine Safety Shutdown Switch	7-16
E. Murphy "Engine Oil Press" gage	7-16
F. Murphy "Engine Coolant Temp" gage	7-17
G. Murphy "Hyd Oil Temp" gage	7-17
H. Hydraulic Oil Level Float Switch	7-17
I. "Emergency Stop" button	7-17
J. Pilot lights	7-17
K. Engine Control Switches "OFF-ON-START"	7-18
L. "LOCAL--PENDANT" Switch	7-18
M. Governor Control Switches "RAISE-off-LOWER"	7-18
N. Clamp Control Switches ("OPEN-off-CLOSE")	7-18
O. Drive Control Switches ("FORWARD/off/REVERSE")	7-19
P. Phase Control Switches ("OUT/IN")	7-19
Q. Phase Control Switches ("AUTO")	7-20
R. Preparing the Electrical System for Engine Startup	7-20
S. Electrical Schematic	7-21
VII-3. Control Pendant	7-23
A. Control Pendant Wiring Diagram	7-24



OPERATION / MAINTENANCE MANUAL

MODEL 250VM VIBRATORY DRIVER WITH MODEL 700VM POWER UNIT

7032 SOUTH 196th - KENT, WA. 98032 - (253) 872-0141 / FAX (253) 872-8710

Safety Precautions

(This list of precautions must be followed at all times to ensure personal & equipment safety.)

1. Read this manual from beginning to end before operating or working on this machine.
2. When operating in a closed area, pipe exhaust fumes outside. (**WARNING:** Breathing exhaust fumes can cause serious injury and even death.)
3. When servicing batteries, avoid any type of spark or open flame. Batteries generate explosive gases during charging. There must be proper ventilation when charging batteries.
4. Never Adjust or repair the unit while it is in operation.
5. Make sure the Control Pendant is in the "OFF" position before starting the unit.
6. Remove all tools and electrical cords before starting the unit.
7. Keep oily rags away from the exhaust system.
8. Never store flammable liquids near the engine.
9. Never stand under vibro at any time and keep your eyes on the vibro when it is in operation. Keep a look out for loose bolts or leaking hydraulic lines.
10. Avoid pulling on hose quick dis-connect fittings. Move power unit closer to work if hoses cannot reach. Do not use hoses as a tow line to tug the power unit! If a hose fails at the hydraulic couplers then it is a result of "hose tugging by the pile crew".
11. Avoid kinks in the hoses. Kinks will cut the hose safety factor by 50 percent.
12. Always wear eye and ear protection.
13. Avoid standing downwind of vibrating piles. Dirt and other matter may become airborne and fall into the unprotected eye.
14. Always wear a hardhat, gloves, and safety shoes.
15. Always attach safety line to pile when extracting or hoisting into position.
16. (**WARNING**) Never clamp vibro to pile and dis-connect from crane line. Lay vibro down on ground when not in use.
17. Do not truck power unit with quick disconnect caps and plugs screwed on to fittings unless the caps and plugs have wire rope safety lines attached. Store in storage box under control panel.



OPERATION / MAINTENANCE MANUAL

MODEL 250VM VIBRATORY DRIVER WITH MODEL 700VM POWER UNIT

7032 SOUTH 196th - KENT, WA. 98032 - (253) 872-0141 / FAX (253) 872-8710

Illustration List		
Figure	Title	Page
1-A.	Machine Features	1-1
1-B.	General Description of 250VM Vibro	1-3
1-C.	General Description of Suppressor Housing	1-4
1-D.	General Description of Vibratory Gearbox	1-5
1-E.	General Description of Clamp Attachment	1-6
1-F.	Clamp Attachment Hole Configuration	1-6
1-G.	Optional Attachments	1-7
1-H.	General Description of Model 700VM Power Unit	1-8
2-A.	250VM Assembly Identification	2-2
2-B.	Suppressor Identification	2-4
2-C.	Gearbox Identification	2-6
2-D.	Phase Shifter Identification	2-8
2-E.	Clamp Identification	2-10
2-F.	Hose Identification	2-12
2-G.	Model 700VM Power Unit Skid Identification	2-14
2-H.	Quick Disconnect Coupling Identification	2-15
2-I.	Tool Set Identification	2-16
2-J.	Caisson Clamp Identification	2-17
2-K.	Control Panel	2-18
2-L.	Control Panel - Gages	2-21
2-M.	Control Pendant and Parts	2-22
4-A.	Power Unit Coupler Layout	4-2
4-B.	Bleeding Clamp Attachment	4-3
4-C.	Setting Relief Valve	4-5
4-D.	Checking Clamp Pressure Switch Setting	4-6
4-E.	Control Pendant	4-8
5-A.	Hydraulic Pump Drive	5-7
7-A.	Schematic Power Unit Hydraulic	7-2
7-B.	Clamp Drill Manifold Detail	7-3
7-C.	Schematic Hydraulic - Clamp / Drill Manifold	7-4
7-D.	Drive Manifold Detail	7-5
7-E.	Schematic Hydraulic - Drive Manifold	7-6
7-F.	Phase IN / Phase OUT Manifold Detail	7-7
7-G.	Schematic Hydraulic Phase IN /Phase OUT Manifold	7-8
7-H.	Tank Detail	7-11
7-I.	Hydraulic Pumps w/ Dump Valve Detail	7-14
7-J.	Schematic Power Unit Electrical	7-21
7-K.	Electrical Symbol Legend	7-22
7-L.	Control Pendant - Detail	7-23
7-M.	Schematic Control Pendant	7-24

Table List		
Table	Title	Page
1-A.	Machine Specifications - Model 250VM Vibro	1-2
1-B.	Machine Specifications - Model 700VM Power Unit	1-2
2-A.	250VM Assembly	2-3
2-B.	Suppressor	2-5
2-C.	Gearbox	2-7
2-D.	Phase Shifter	2-9
2-E.	Clamp	2-11
2-F.	Hose Identification	2-13
2-G.	Model 700VM Power Unit Skid Identification	2-14
2-H.	Quick Disconnect Coupling Identification	2-15
2-I.	Tool Set Identification	2-16
2-J.	Caisson Clamp Identification	2-17
2-K.	Control Panel and Parts	2-19
2-L.	Control Panel - Gages	2-21
2-M.	Control Pendant and Parts	2-23
5-A.	Power Unit - Filters, Fluid Types and Capacities	5-3
6-A.	Trouble-Shooting	6-1
7-A.	Clamp / Drill Manifold	7-3
7-B.	Drive Manifold	7-5
7-C.	Phase IN / Phase OUT	7-7
7-D.	Hydraulic Hose Identification and Routing	7-10
7-E.	Tank Detail	7-12
7-F.	Hydraulic Pumps w/ Dump Valve	7-14



OPERATION / MAINTENANCE MANUAL

MODEL 250VM VIBRATORY DRIVER WITH MODEL 700VM POWER UNIT

7032 SOUTH 196th - KENT, WA. 98032 - (253) 872-0141 / FAX (253) 872-8710

Warranty

American Piledriving Equipment, Inc. J&M Foundation Equipment LLC STANDARD WARRANTY

American Piledriving Equipment, Inc./J&M Foundation Equipment LLC (APE/J&M) warrants new products sold by it to be free from defects in material or workmanship for a period of one year after the date of delivery to the first user and subject to the following conditions:

APE/J&M's obligation and liability under this WARRANTY is expressly limited to repairing or replacing at APE/J&M's option, any parts which appear to APE/J&M upon inspection to have been defective in material or

workmanship. Such parts shall be provided at no cost to the user, at the business establishment of APE/J&M or the authorized APE/J&M distributor of the product during regular working hours. This WARRANTY, shall not apply to component parts or accessories of products not manufactured by APE/J&M and which carry the warranty of the manufacturer thereof, or to normal maintenance (scraped and scived lube and fuel lines, worn cushion material in the drive base) or normal maintenance parts (such as fouled injectors, weakened check valve springs, damaged grease zirts caused by use over time).

Replacement or repair parts installed in the product covered by this WARRANTY are warranted only for the remainder of the warranty as if such parts were original components of said product. APE/J&M makes no other warranty, expressed or implied and makes no warranty of merchantability of fitness for any particular purpose.

APE's obligation under this WARRANTY shall not include any transportation charges, costs of installation, duty, taxes or any other charges whatsoever, or any liability for direct, indirect, incidental or consequential damage or delay. If requested by APE/J&M, products or parts for which a warranty claim is made are to be returned transportation prepaid to APE/J&M. Any improper use, including operation after discovery of defective or worn parts, operation beyond rated capacity, substitution of any parts whatsoever, or parts not approved by APE/J&M or any alteration or repair by others in such manner as in APE/J&M's judgment affects the product materially and adversely, shall void this warranty.

ANY TYPE OF WELDING ON EQUIPMENT WILL VOID THE WARRANTY

Refusal: Vibros: If the pile does not move one foot in 30 seconds of vibro operation at full speed. Resort to a larger vibro. APE/J&M equipment may exceed the refusal driving criteria for short periods of time as may be needed to penetrate hard soil layers or obstacles. In such cases, a heat gun is used to monitor the temperature of the bearings and related components to prevent use of the machine beyond 210 degrees. Contact APE/J&M or your local APE/J&M distributor for special instructions when faced with refusal conditions.

Refusal: Diesels: Do not exceed 10 blows per inch or 120 blows per foot. In cases of setting of the pile it is permitted to increase the blow count to 250 blows per foot, but only for one foot of driving penetration. Pile inspectors should consult the APE factory for permission to exceed these limits. Failure to do so will void the warranty. This standard specification is accepted by the DFI (Deep Foundations Institute) and the PDCA

(Pile Contractors Association) and by all manufacturers of pile driving equipment.

I-1. Machine Features. - Model 250VM Vibratory Hammer

Patented breakthrough suppressor cuts down weight while increasing line pull.

Suppressor is modular and can be removed to reduce suspended weight and height.

One piece eccentric/ gear design eliminates bolts, keyways, splines and pins.

Eccentrics filled with "heavy metals" (250V only) produce more amplitude with less parts.

Giant spherical bearings are five times larger than those found on other machines.

Hydraulic motor is recessed which eliminates the need for bolted on guards. Less parts - less problems.

Heavy cylinder needs no guards and all hoses are tucked out of harms way. The one piece design eliminates rear seals, tie rods & nuts.

Shortest vibro in its class. Gain more headroom and reach.

Safety pin prevents over-pullings.

150 Ton pull.

Gear box incorporates a machined O-ring groove to seal the top plate with no leaky gaskets.

Rifle bored top plate eliminates unwanted hoses that can cause serious downtime. (15-less hoses.)

Computer designed gear-box is perfectly balanced with low center of gravity. Release crane line without the worry of bending piles.

Phase-shifter provides infinite amplitude control, eliminating vibration during start-up and stopping. Also, eliminates crane line vibration.

The 250V vibro can be shipped fully assembled on a Boeing 747 aircraft.

Gear box drilled to accept attachments manufactured by APE and by other manufacturers.

High speed gear train will allow vibro to operate off many different power units.

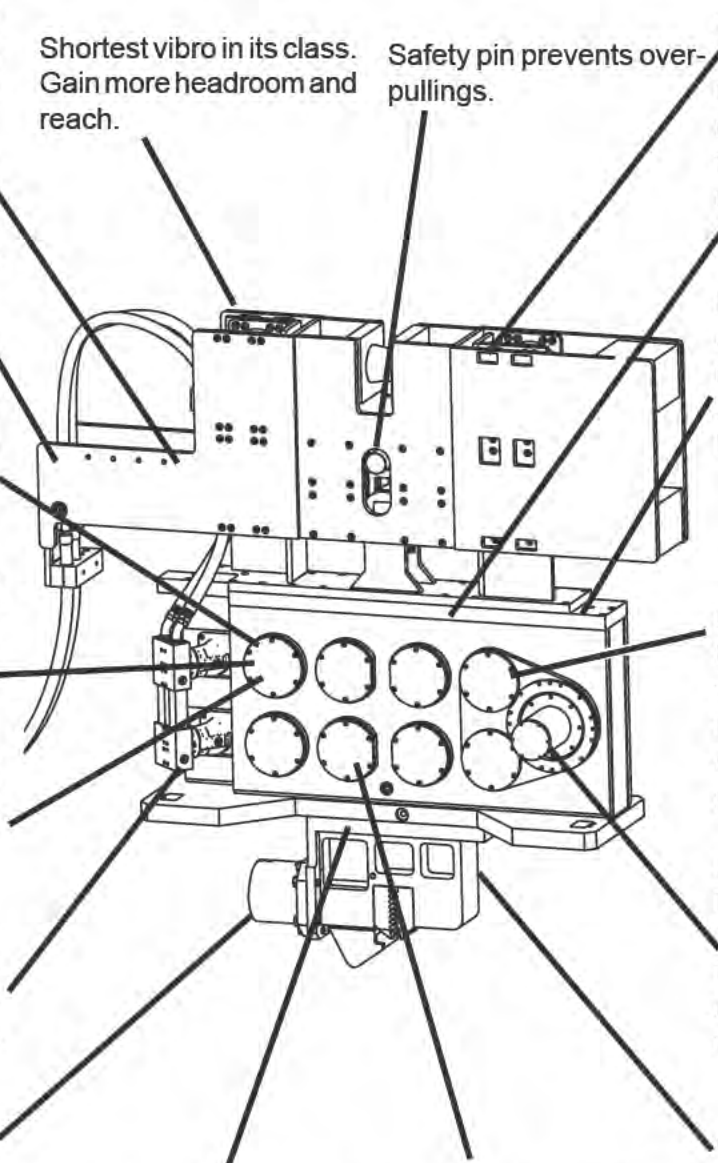

Figure 1-A. Machine Features



OPERATION / MAINTENANCE MANUAL

MODEL 250VM VIBRATORY DRIVER WITH MODEL 700VM POWER UNIT

7032 SOUTH 196th - KENT, WA. 98032 - (253) 872-0141 / FAX (253) 872-8710

I. GENERAL INFORMATION (Continued...)

I-2. Machine Specifications

I-2A. Model 250VM Vibro

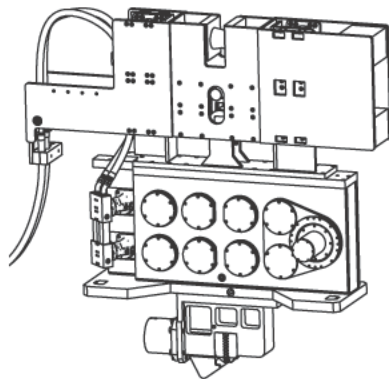

Model 250VM

Eccentric Moment	4,500 in-lbs (52 kg-m)
Drive Force	243 Tons (2,224 kN)
Frequency (cpm)	400 to 1,950
Amplitude w/o attachment	1.25" (32 mm)
Pile Clamp Force	125 Tons (1,112 kN)
Line Pull for Extraction	150 Tons (1,335 kN)
Hydraulic Hose Length	150' (45 m)
Suspended Weight*	17,500 lbs. (7,936 kg)
Length	125" (318 mm)
Width at Throat	14" (356 mm)
Height	83.6" (2,124 mm)
Height with Clamp*	113" (2,870 mm)

*Weight and height includes sheeting clamp and 1/2 of hose bundle.

**Drive force increases with increase in frequency. However, an increase in drive force may reduce productivity in some soils. APE provides variable frequency on all v bros so that frequency can be adjusted to suit many different soil conditions. For more details on what frequency works best for the soil conditions on your site please call APE directly.

Table 1-A. - Vibro

I-2B. Model 700VM Power Unit

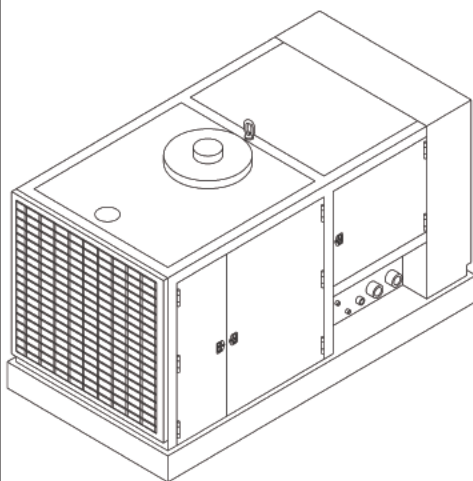

Model 700VM

Engine	700h.p Caterpillar C18
Maximum Power	700(522 kW)
Operating Speed	800 to 1950 rpm
Maximum Drive Pressure	5,000 psi (344 bar)
Hyd. Flow-FWD/REV	170 gpm (644 lpm)
Max.Hyd.Flow-HI	195 gpm (738lpm)
Clamp Pressure	4,800 psi (331 bar)
Clamp Pump Flow	10 gpm (38 lpm)
Weight	9,000 lbs (8,618 kg)
Length	152" (3,861 mm)
Width	82.25" (2089 mm)
Height	94" (2388 mm)

**Dimensions may vary depending on the year and model.
Consult the factory for certifications on unit being used.**

Table 1-B. - Power Unit

I. GENERAL INFORMATION (Continued...)

I-3. General Description of Model 250VM Vibro

The **APE Model 250VM** is a variable frequency vibratory pile driver/extractor designed to drive and extract all types of piles including sheet, pipe, timber, concrete, H-beam, I-beam and steel plates. In addition, the vibrator can be used for soil compaction, installing well casings, and installation of tie-backs and wick drains.

The Model 250VM operates in a frequency range of 400 to 1,950 cycles per minute depending on the hydraulic flow and on the hydraulic motors fitted to the gear train. The Model 250VM is especially suited for driving or extracting piles that are near buildings or other structures. This is because the Model 250VM employs a phase shifter that eliminates vibration during start-up and stopping, and, during driving, vibrates at higher frequencies and thus is less damaging to surrounding soils.

The three major parts to the Model 250VM are as follows:

- A.) The Suppressor housing.**
- B.) The Gearbox.**
- C.) The Phase Shifter**
- D.) The Clamping Attachment.**

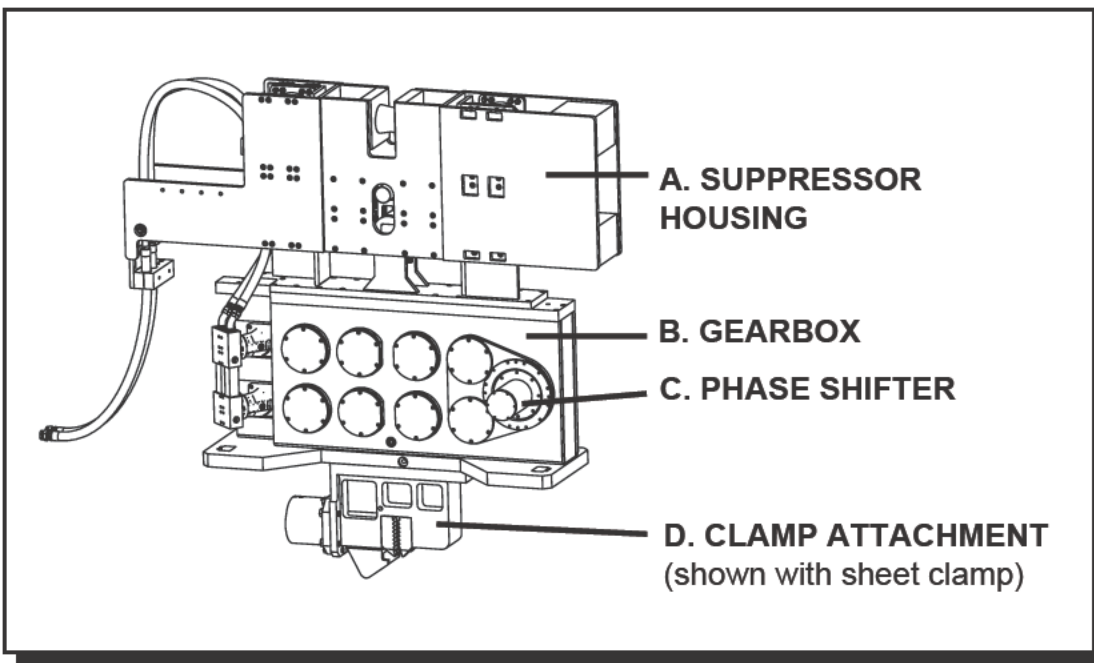

Figure 1-B. General Description of 250VM Vibro.

I. GENERAL INFORMATION (Continued...)

I-3A. The Suppressor Housing

The suppressor housing utilizes a total of four, first stage large elastomers and 8 small, second, stage small elastomers. During extraction, the first stage displaces approximately 4 inches and then engages the inner second stage and engagement pin plate. The engagement pin will then come into motion and provide an additional 8 inches until the safety pin bottoms out in the visual slot registering the total line pull with a total maximum line pull of 128 tons to 150 tons depending upon the stiffness of the elastomers installed. (**WARNING! Hard pulling for long periods of time will heat and damage the large elastomers. The heat generated from constant heavy line pull will destroy the chemical bond between the rubber and mounting plate which will cause elastomer failure.**) When engaged in hard extracting, break every 15 minutes to allow elastomers to cool.

Note: for better operations it has been discovered that slightly reducing the oil level in the vibrator gearcase will reduce heat. In these cases, fill the gearbox until the oil level is half way up the sight glass and then drain until the level is near the bottom.

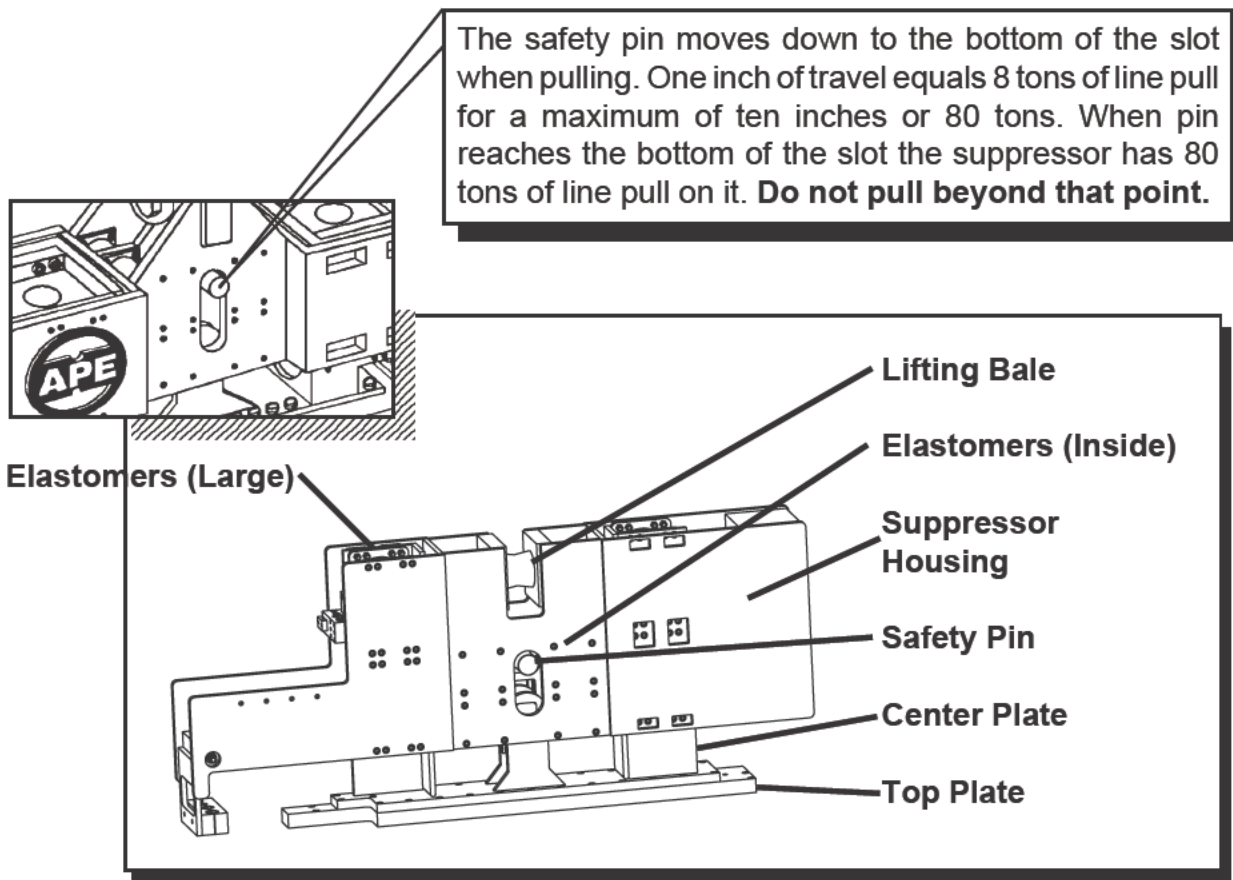

Figure 1-C. General Description of Suppressor Housing.

I. GENERAL INFORMATION (Continued...)

I-3B. The Vibrator Gearbox

The vibrator gearbox contains eight high amplitude eccentric weights cast in one piece with the gear. This design is unique to the industry and was developed by the engineers of APE to solve a number of problems associated with other types of vibrator machines. The eccentric and the drive gears have been helically cut to provide high speed operation with reduced noise and wear. During start-up and stopping, the eccentrics are phased such that there is no vibration. Upon operator command, the phase shifter causes the eccentrics to work together. Vibration is caused by the vertical movement created when the eccentrics are rotated. The eccentric and drive gears are all driven in line by a Rexroth 180 motor tucked in on the outboard side of the gearbox. The motor is recessed for maximum protection. The eccentrics rotate on eight shafts housed by sixteen giant spherical bearings. The gears and bearings receive lubrication as a result of the fluid splashing inside the gearbox when the gears are rotated. The oil level is quickly determined by looking at the site gauge. The Model 250VM can be operated under water to a depth of 30 feet without modifications. (Consult factory for depths below 30 feet.)

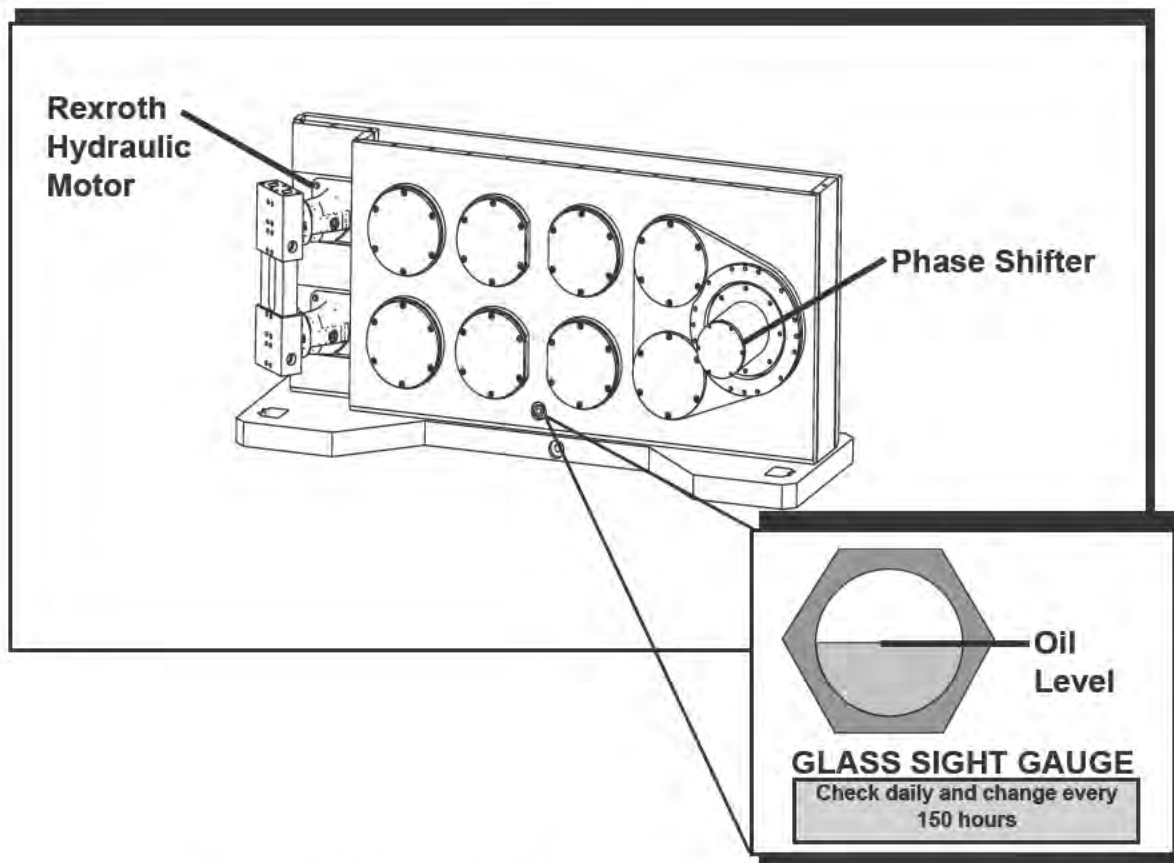

Figure 1-D. General Description of Vibrator Gearbox.



OPERATION / MAINTENANCE MANUAL

MODEL 250VM VIBRATORY DRIVER WITH MODEL 700VM POWER UNIT

7032 SOUTH 196th - KENT, WA. 98032 - (253) 872-0141 / FAX (253) 872-8710

I. GENERAL INFORMATION (Continued...)

I-3C. The Clamp Attachment

The APE 250VM come with a **standard sheet pile clamp attachment**. The clamp contains two gripping jaws. One is "fixed" and one is "moveable". A large hydraulic cylinder operates the moveable jaw with up to 250 tons of clamping force depending on clamp pump relief pressure. The jaws open and close by turning a switch on the remote control pendant or may be operated by turning the switch at the main control panel mounted behind one of the doors on the power unit. The valve can be manually operated with a screwdriver if all electrical fails. **The APE standard sheet pile clamp** can be fitted with jaws to fit many different types of piles including sheet piles, H-Beams, steel plates, steel rods, pipe piles, wood piles, and concrete piles. (Contact APE or your local APE distributor for more information on clamp attachments for special pile types.)

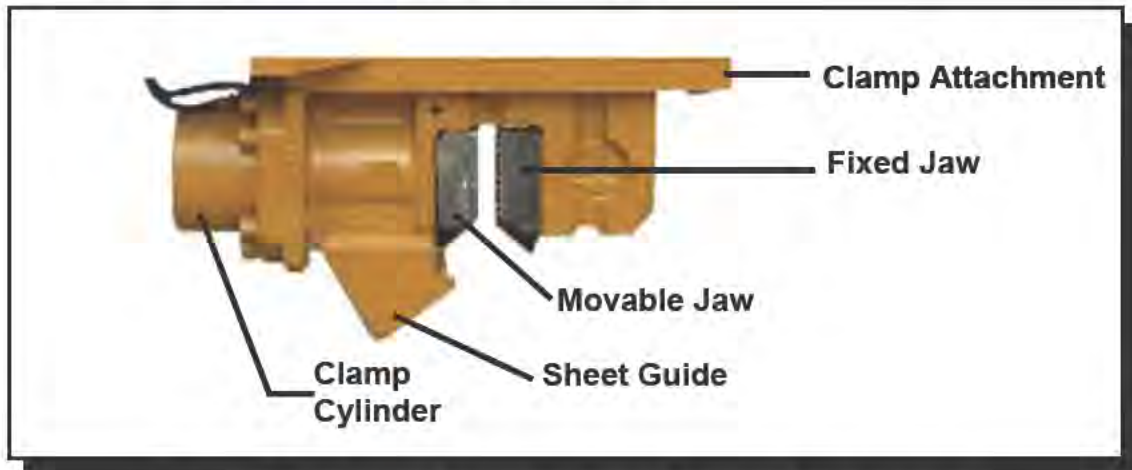

Figure 1-E. General Description of Clamp Attachment.

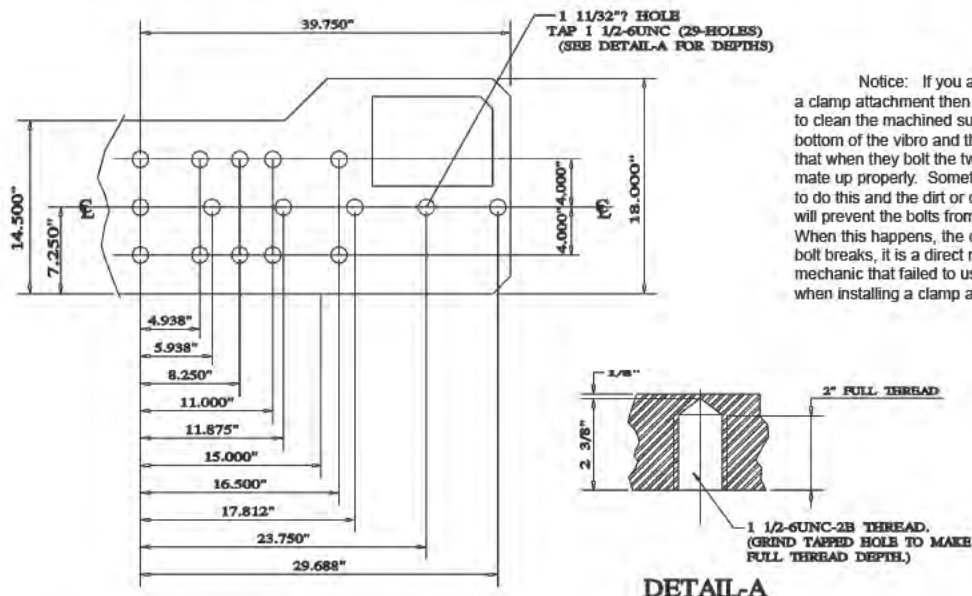

Figure 1-F. Clamp Attachment Hole Configuration.



OPERATION / MAINTENANCE MANUAL

MODEL 250VM VIBRATORY DRIVER WITH MODEL 700VM POWER UNIT

7032 SOUTH 196th - KENT, WA. 98032 - (253) 872-0141 / FAX (253) 872-8710

I. GENERAL INFORMATION (Continued...)

I-3D. Optional Attachments

The following are some of the optional attachments for the Model 250VM Vibratory hammer. (Contact APE or your local APE distributor for more information about these and other available equipment.)

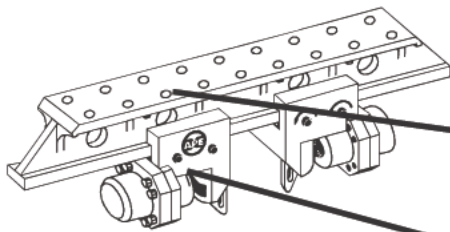

7 ft. Caisson Beam (#901000)

8 ft. Caisson Beam (#902000)

11ft. Caisson Beam (#903000)

Caisson Clamp (#250000)

APE CAISSON CLAMP

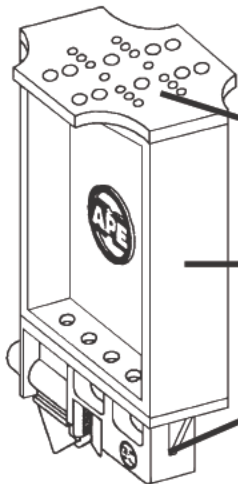

**90 Degree Adapter
Plate (#905000)**

**4 ft. Extension Adapter
(#906000)**

Clamp Attachment

APE 90 DEGREE ADAPTER WITH EXTENSION

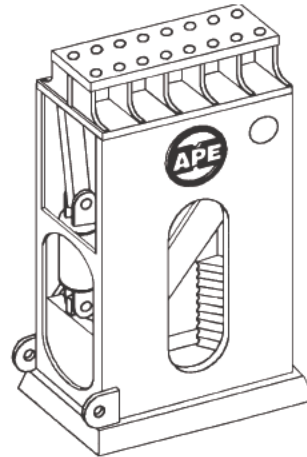

APE DELUXE WOOD CLAMP (#907000)

Figure 1-G. Optional Attachments



OPERATION / MAINTENANCE MANUAL

MODEL 250VM VIBRATORY DRIVER WITH MODEL 700VM POWER UNIT

7032 SOUTH 196th - KENT, WA. 98032 - (253) 872-0141 / FAX (253) 872-8710

I. GENERAL INFORMATION (Continued...)

I-4. General Description of Model 700V Power Unit

The 250VM vibrator runs off the APE 700VM power unit. The APE 700VM has a 700 horsepower (522kW) CATERPILLAR C18 engine. The engine is mounted to a tubular frame that also serves as a diesel fuel tank. A sheet metal and tube frame covers the engine and is equipped with locking doors for protection from the environment. A control panel is located behind one of the doors and comes complete with a 50 foot (15.2 M) control pendant. There are two hydraulic tanks on the power unit. One is the main tank and the other is a storage tank for extra oil in case the main tank becomes depleted. A hydraulic tank supplies oil to four pumps. Two pumps feed the vibrator motors. A small dual pump feeds the clamp attachment and phase shifter. There is also a recirculation pump to keep the oil cool and filtered. The Vibrator is connected to the power unit via eight hydraulic hoses. The 1 1/2" (ID) hoses are the pressure line and the return line for the vibrator motors. Two small 3/8" (ID) hoses are for the clamp system, and two 3/8" (ID) hoses are for the phase shifter. The 3/4" (ID) hose is for the vibrator motor case drain line, and the 1/2" (ID) hose is for the phase shifter filter manifold drain line. The hoses are attached to the power unit by connecting the "quick disconnect fittings" on the end of the hoses leading from the vibrator. The fittings go on only one way so there is no chance of hooking up the hoses improperly.

WARNING: Clean with ether or a clean rag before installing quick disconnects. Make sure you seat the quick disconnect fittings all the way tight. Failure to tighten the quick disconnects will stop the flow of oil and will prevent the vibro from operating. Failure to tighten the clamp fittings completely tight will cause the jaws to either not open or not close. If this happens you may have to crack the fitting and bleed off the pressure to release the quick disconnects.

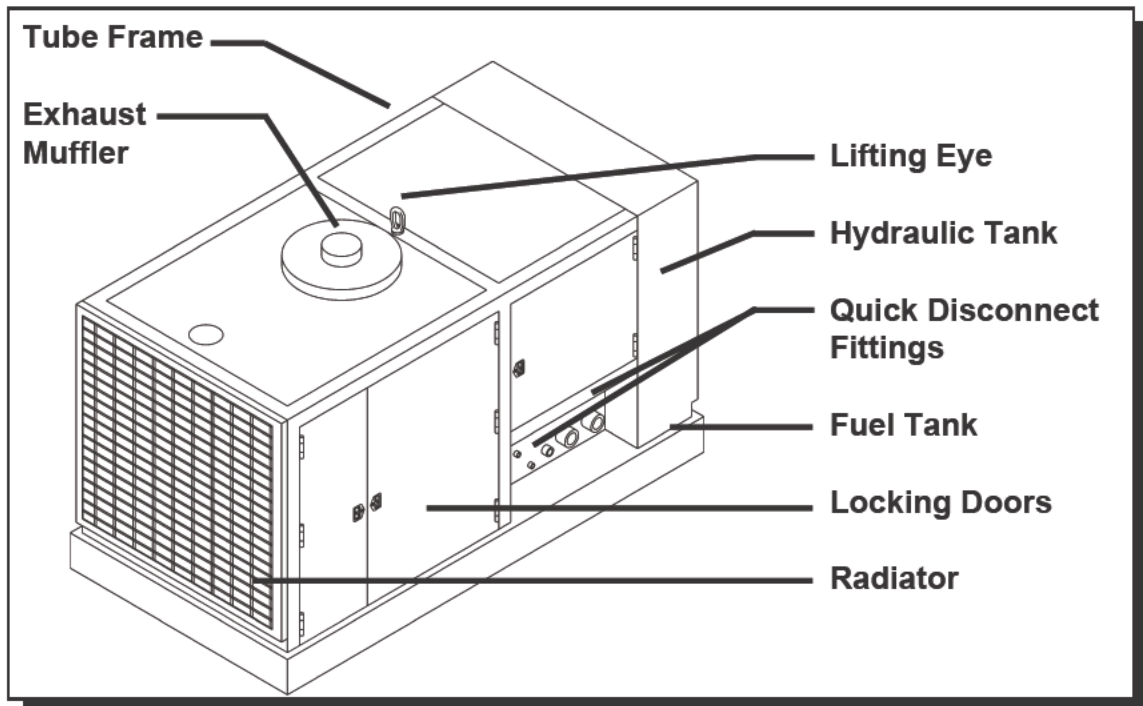

Figure 1-H. General Description of Model 700VM Power Unit

OPERATION / MAINTENANCE MANUAL

MODEL 250VM VIBRATORY DRIVER WITH MODEL 700VM POWER UNIT

7032 SOUTH 196th - KENT, WA. 98032 - (253) 872-0141 / FAX (253) 872-8710

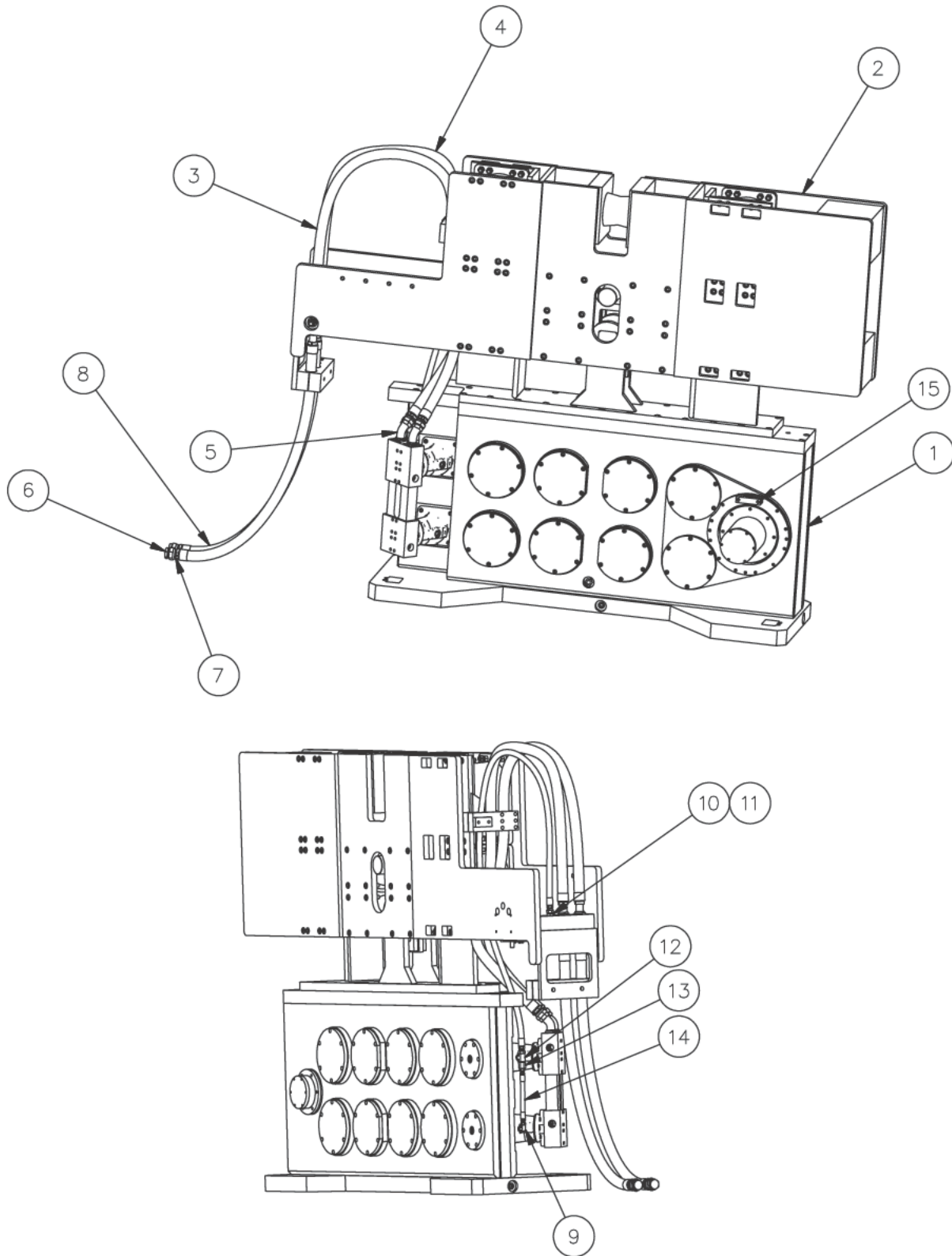

Figure 2-A. Model 250VM Assembly



OPERATION / MAINTENANCE MANUAL

MODEL 250VM VIBRATORY DRIVER WITH MODEL 700VM POWER UNIT

7032 SOUTH 196th - KENT, WA. 98032 - (253) 872-0141 / FAX (253) 872-8710

Parts List			
ITEM	QTY	STOCK NUMBER	DESCRIPTION
1	1	APE P/N	TRANSMISSION ASSEMBLY
2	1		SUPPRESSOR ASSEMBLY
3	1		HOSE150R13F024J024L12300
4	1		HOSE150R13F024J024L12300
5	2		FITT2V-24F24M
6	2		FITT2P-24M
7	1		HOSE150R13F024J024L07200
8	1		HOSE150R13F024J024L07200
9	1		FITT2L-08M10R
10	1	100609	FITT2S-12M12R000-000H001
11	1		HOSE075R02J012J012L11300
12	1		FITT2T-12M12M10R
13	1		FITT2S-12J08M
14	1		HOSE050R02J008J008L01200
15	1		SHIFTER HOSE BLOCK

Table 2-A. Model 250VM Assembly

II. MAJOR COMPONENT DEFINITION

II-1. Suppressor Identification

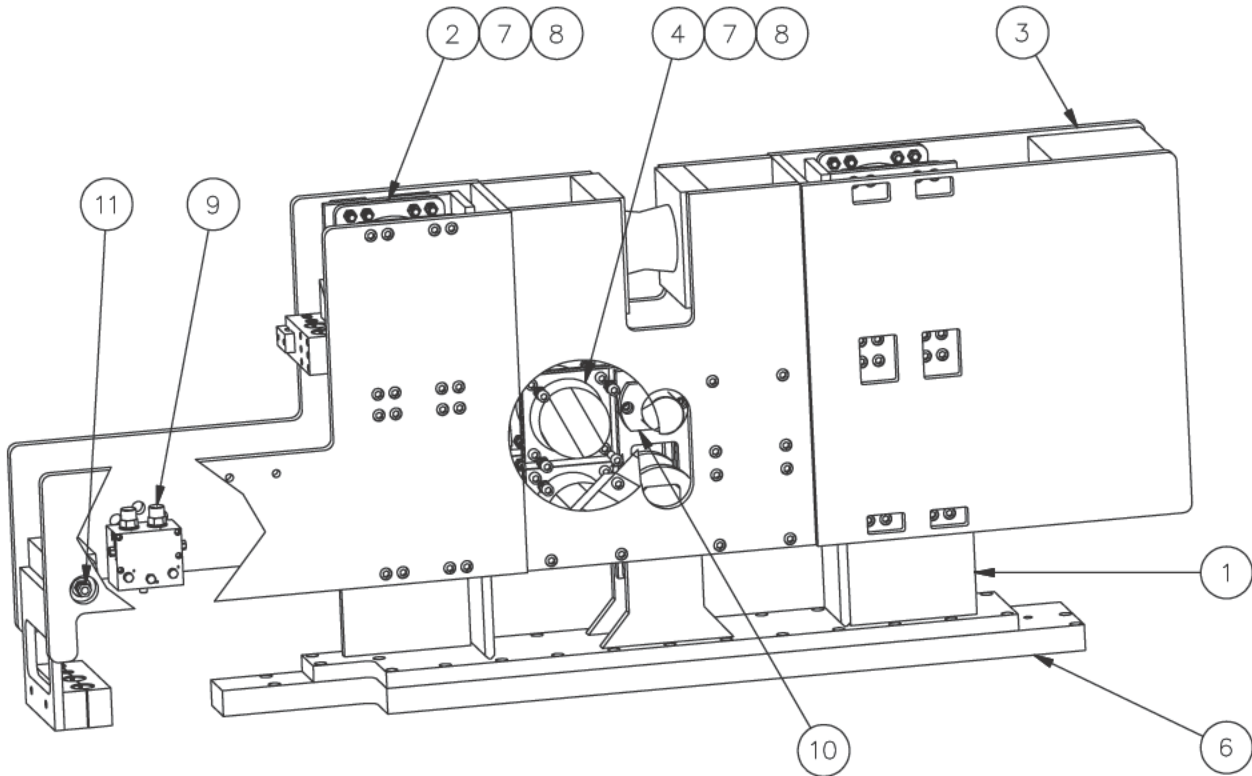

Figure 2-B. Model 250VM Suppressor



OPERATION / MAINTENANCE MANUAL

MODEL 250VM VIBRATORY DRIVER WITH MODEL 700VM POWER UNIT

7032 SOUTH 196th - KENT, WA. 98032 - (253) 872-0141 / FAX (253) 872-8710

Parts List			
ITEM	QTY	STOCK NUMBER	DESCRIPTION
1	1		INNER SUPPRESSOR HOUSING
2	4		LARGE ELASTOMER
3	1		SUPPRESSOR HOUSING
4	8		ELASTOMER
5	1		CENTER MOUNTING PLATE
6	1		TOP PLATE
7	112		0.75-10UNC X 2.50 SHCS
8	104		0.75-10UNC HEX NUT
9	1		FILTER MANIFOLD ASM
10	1		STOP PIN
11	1		POP OFF RELIEF

Table 2-B. Model 250VM Suppressor Components

II. MAJOR COMPONENT DEFINITION

II-2. Gearbox Identification

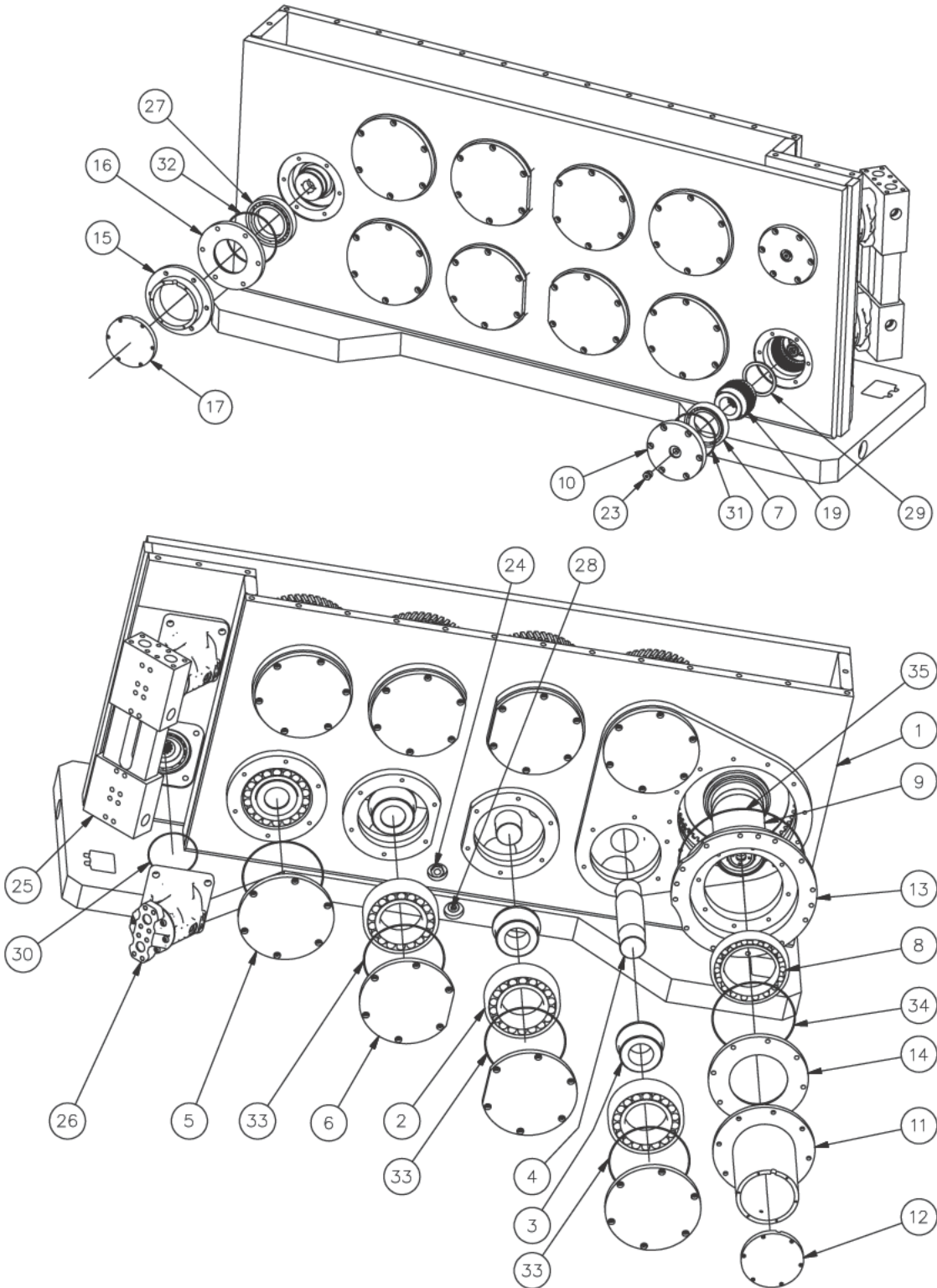

Figure 2-C. Model 250VM Gearbox



OPERATION / MAINTENANCE MANUAL

MODEL 250VM VIBRATORY DRIVER WITH MODEL 700VM POWER UNIT

7032 SOUTH 196th - KENT, WA. 98032 - (253) 872-0141 / FAX (253) 872-8710

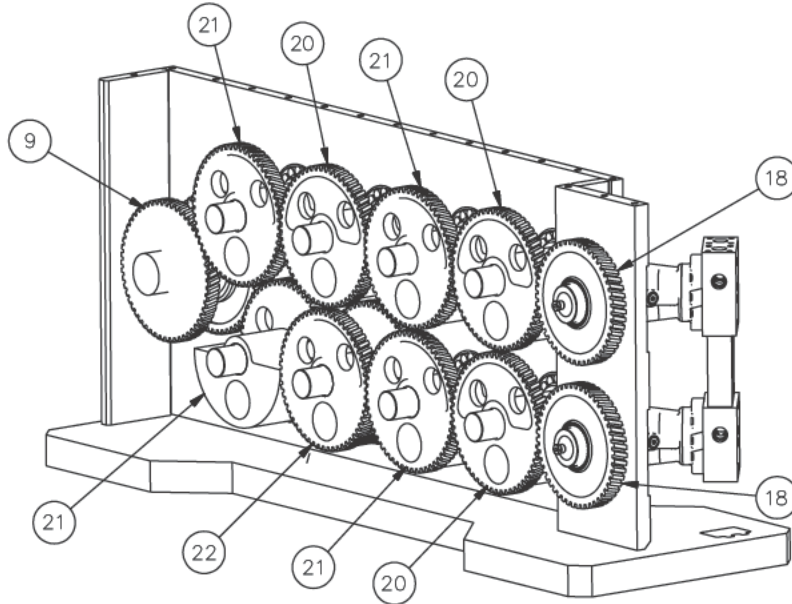

Parts List			
ITEM	QTY	STOCK NUMBER	DESCRIPTION
1	1	V120-001	GEAR BOX FRAME
2	16	121001A	EC CENTRIC BEARING
3	16	V120-005	EC CENTRIC SHAFT SLEEVE
4	8	V120003	EC CENTRIC SHAFT
5	8		EC CENTRIC BEARING COVER
6	8	V120-004	EC CENTRIC BEARING COVER EDGE CUT
7	4	122002	MOTOR BEARING
8	1	V120-012	LARGE PHASE SHIFTER BEARING
9	1		PHASE SHIFTER ASM
10	2	122005	BEARING COVER W/BREATHER PORT
11	1	V170-015	PHASE SHIFTER GUARD
12	1	V170-018	PHASE SHIFTER GUARD END PLATE
13	1	V170-002	PHASE SHIFTER BEARING CARRIER
14	1		PHASE SHIFTER BEARING COVER
15	1	V170-013	SMALL PHASE SHIFTER GUARD
16	1		PHASE SHIFTER BEARING COVER
17	1	V170-017	SMALL PHASE SHIFTER GUARD END PLATE
18	2	152006	DRIVE GEAR RIGHT HAND
19	2	122010	GEAR CARRIER
20	3		EC CENTRIC LEFT HAND
21	4		EC CENTRIC RIGHT HAND
22	1		DOUBLE GEAR LEFT HAND
23	2	122015	GEAR BOX BREATHER
24	1	123005	SIGHT GLASS
25	1		MOTOR MANIFOLD
26	2	152001A	GEAR BOX MOTOR (180)
27	1	V120-011	6022 BALL BEARING
28	3	123004	1" MAG PIPE PLUG
29	4	V120-009	GEAR SPACER
30	2		2-162 O-RING
31	2	100680	2-258 O-RING
32	1		2-262 O-RING
33	16	352081	2-272 O-RING
34	1		2-273 O-RING
35	1		2-281 O-RING

Table 2-C. Model 250VM Gearbox Components

II. COMPONENT DEFINITION

II-3. 250VM Phase Shifter Identification

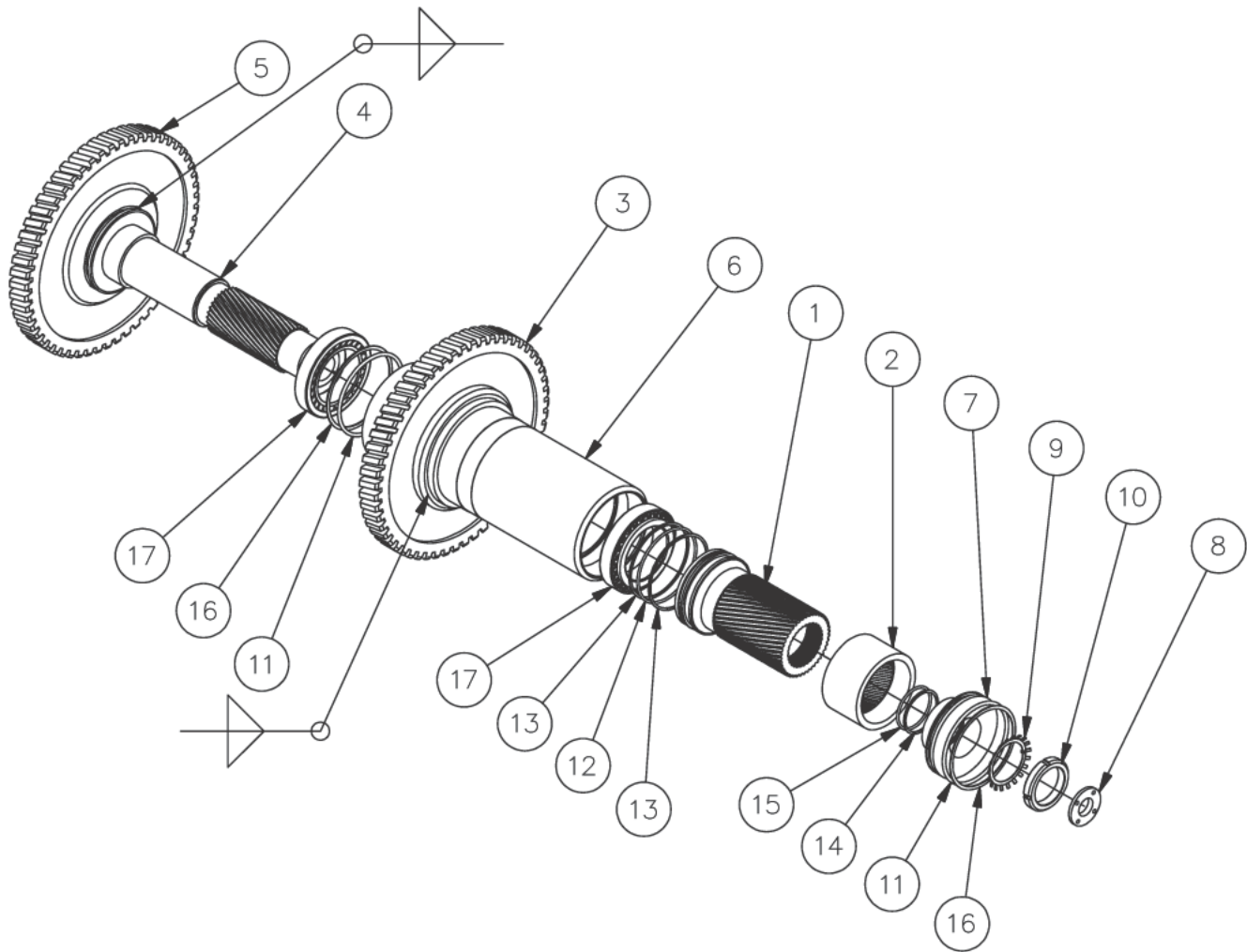

Figure 2-D. 250VM Phase Shifter Assembly



OPERATION / MAINTENANCE MANUAL

MODEL 250VM VIBRATORY DRIVER WITH MODEL 700VM POWER UNIT

7032 SOUTH 196th - KENT, WA. 98032 - (253) 872-0141 / FAX (253) 872-8710

Parts List			
ITEM	QTY	STOCK NUMBER	DESCRIPTION
1	1		PISTON
2	1		SLPINED SLEEVE
3	1		RIGHT GEAR
4	1		SHAFT
5	1		LEFT GEAR
6	1		HOUSING
7	1		BEARING CARRIER
8	1		END PLATE
9	1		LOCK WASHER
10	1		LOCK NUT
11	2		2-354 O-RING
12	1		2-248 O-RING
13	2		248 PAR BAK
14	1		231 PAR BAK
15	1		2-231 O-RING
16	2		354 PAR BAK
17	2		31018XA TAPPERED ROLLER BEARING

Table 2-D. 250VM Phase Shifter Components

II. COMPONENT DEFINITION

II-4 . Clamp Identification

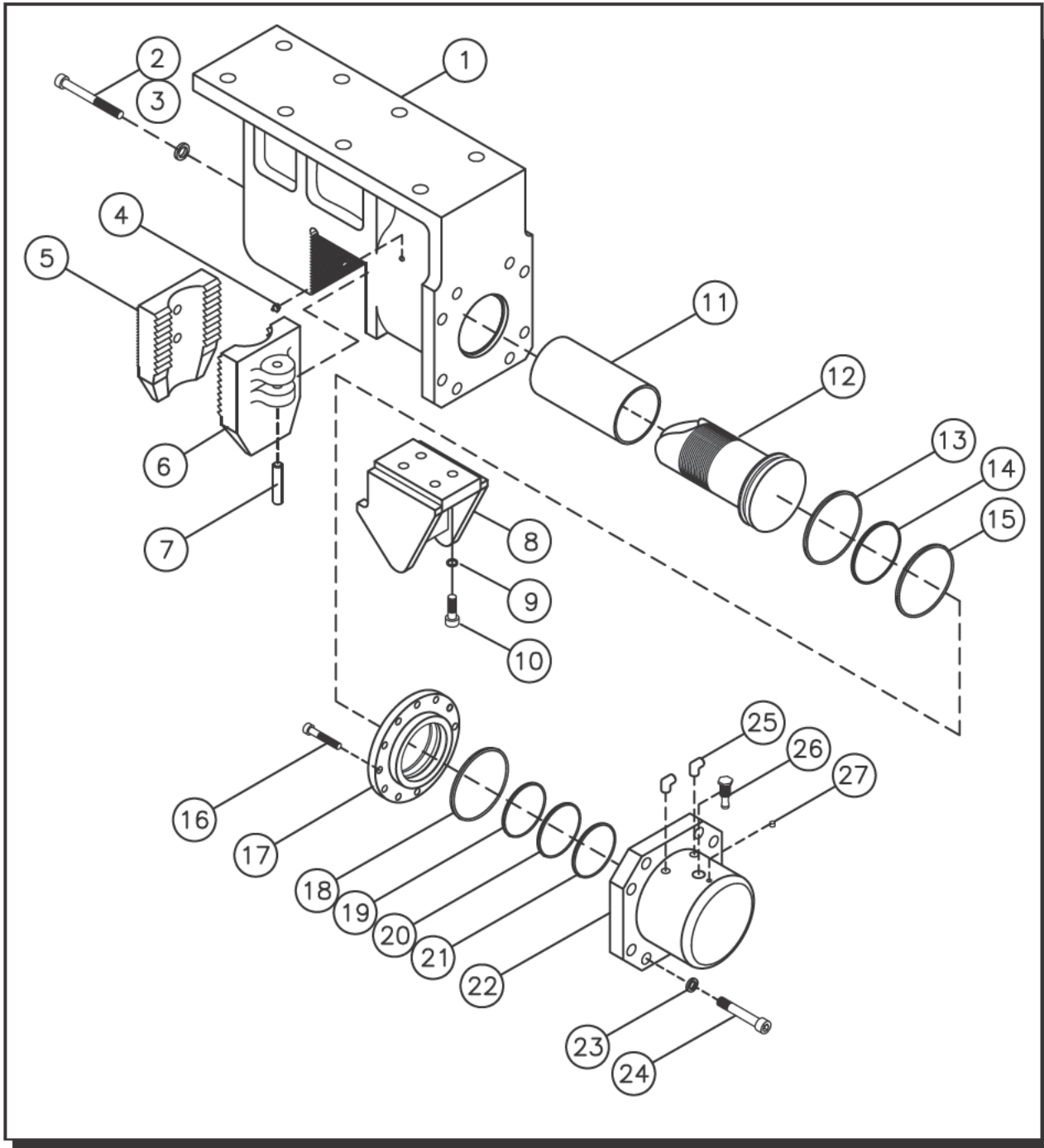

Figure 2-E. Model 200 Clamp Assembly



OPERATION / MAINTENANCE MANUAL

MODEL 250VM VIBRATORY DRIVER WITH MODEL 700VM POWER UNIT

7032 SOUTH 196th - KENT, WA. 98032 - (253) 872-0141 / FAX (253) 872-8710

<u>QTY</u>	<u>DESCRIPTION</u>	<u>PART #</u>
1	Clamp Body	231000
2	Bolt-SHCS 1" NC X 9" Lg	124206
2	1" High Collar Lock Washer	124207
1	1/8" Grease Zerk	221001
1	Fixed Jaw Double	221011
1	Moveable Jaw Double	221005
1	Jaw Pin	221002
1	Sheet Pile Guide	221017
4	1" High Collar Lock Washer	124207
4	Bolt-SHCS 1" NC X 3" Lg	124208
1	Plastic Sleeve	221024
1	Piston / Rod	232007A
1	Parker O-Ring R-5100-128	222010
1	Parker Expander #442	222010
1	Parker Molygard W2-8000-750	222010
12	Bolt-SHCS 5/8 NF (Machined)	124209
1	Cylinder Gland	222004
1	Parker O-Ring 2-367 w/ 8-367	222010
1	Parker Wiper SH959-53	222010
1	Parker Polypack 2500-6000-375B	222010
1	Parker Molygard W2-6250-750	222010
1	Clamp Cylinder Barrel	232001B
8	1-1/4" High Collar Lock Washer	124205
8	Bolt-SHCS 1-1/4" NF X 3-1/2" Lg	124204
2	#6 SAE - #6 JIC 45° Fitting	222002
1	Check Valve	222016
1	#6 SAE Allen Plug	222017
Note: All Seals & O-Rings are part of Seal Kit		222010

Table 2-E. Model 200 Clamp Components

II. COMPONENT DEFINITION (Continued...)

II-5. Hose Identification.

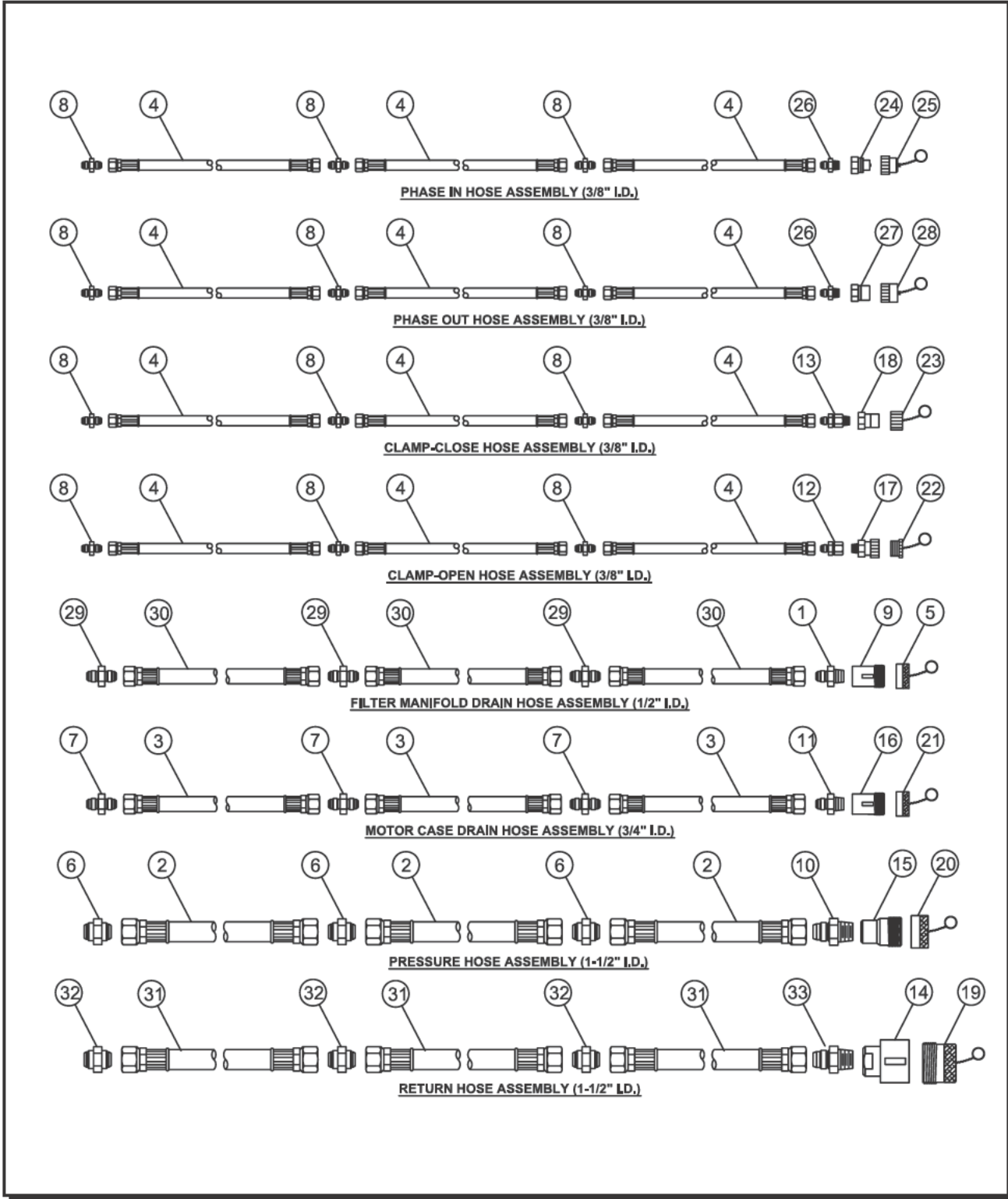

Figure 2-F. Hose Bundle Identification - Vibro.



OPERATION / MAINTENANCE MANUAL

MODEL 250VM VIBRATORY DRIVER WITH MODEL 700VM POWER UNIT

7032 SOUTH 196th - KENT, WA. 98032 - (253) 872-0141 / FAX (253) 872-8710

II. COMPONENT DEFINITION (Continued...)

II-5. Hose Identification.

The following is a general listing of the standard hoses that are shipped with the Model 250VM Vibratory Driver.

Item	Qty	Description	Part No.
1	1	Fitting #8 MJIC/#12 M. Pipe	#555181
2	3	1-1/2" x 50' c/w 1-1/2"2" FJIC e/e Hose (5000 psi rated)	#421008
3	3	3/4" x 50' c/w 12" FJIC e/e Hose (2000 psi rated)	#421009
4	12	3/8" x 50' c/w 3/8" FJIC e/e Hose (CPB 5500 psi)	#421010
5	1	3/4" Dust Cap	#421021
6	3	Fitting #24 Male JIC Union	#421012
7	3	Fitting #16 Male JIC Union	#421013
8	6	Fitting #6 Male JIC Union	#421014
9	1	3/4" QD. Male Coupling	#421020
10	1	Fitting #24 MJIC/#24 M.Pipe	#421015
11	1	Fitting #12 MJIC/#16 M. Pipe	#555175
12	1	Fitting #6 MJIC/#6 F. Pipe	#421011
13	1	Fitting #6 MJIC/#6 M. Pipe	#421017
14	1	1-1/2" QD Female Coupling	#400301
15	1	1-1/2" QD. Male Coupling	#400303
16	1	1" QD Male Coupling	#421020
17	1	3/8" Safeway Female QD #S35-3	#421024
18	1	3/8" Safeway Male QD #S31-3	#421025
19	1	APE 1-1/2" Dust Plug	#400704
20	1	APE 1-1/2" Dust Cap	#400703
21	2	Aeroquip Dust Cap #5100-S7-12	#421021
22	1	3/8" Safeway Plug #S34-3	#421027
23	1	3/8" Safeway Cap #S39-3	#421026
24	1	1/2" QD. Male Coupling	#555161
25	1	1/2" Dust Cap	#555165
26	2	Fitting #6 MJIC/#8 M. Pipe	#555171
27	1	1/2" QD. Female Coupling	#555159
28	1	1/2" Dust Plug	#555169
29	3	Fitting #8 Male JIC Union	#555179
30	3	1/2" x 50' c/w 8" FJIC e/e Hose (2000 psi rated)	#555183
31	3	2" x 50' c/w 2" FJIC e/e (5000psi)	#421008
32	3	Fitting #32 Male JIC Union	#421048
33	1	Fitting #32 Male JIC / #24 M. Pipe	#421051

Table 2-F. Hose Identification - Vibro.



OPERATION / MAINTENANCE MANUAL

MODEL 250VM VIBRATORY DRIVER WITH MODEL 700VM POWER UNIT

7032 SOUTH 196th - KENT, WA. 98032 - (253) 872-0141 / FAX (253) 872-8710

II. COMPONENT DEFINITION (Continued...)

II-6. Model 700VM Power Unit Skid Identification.

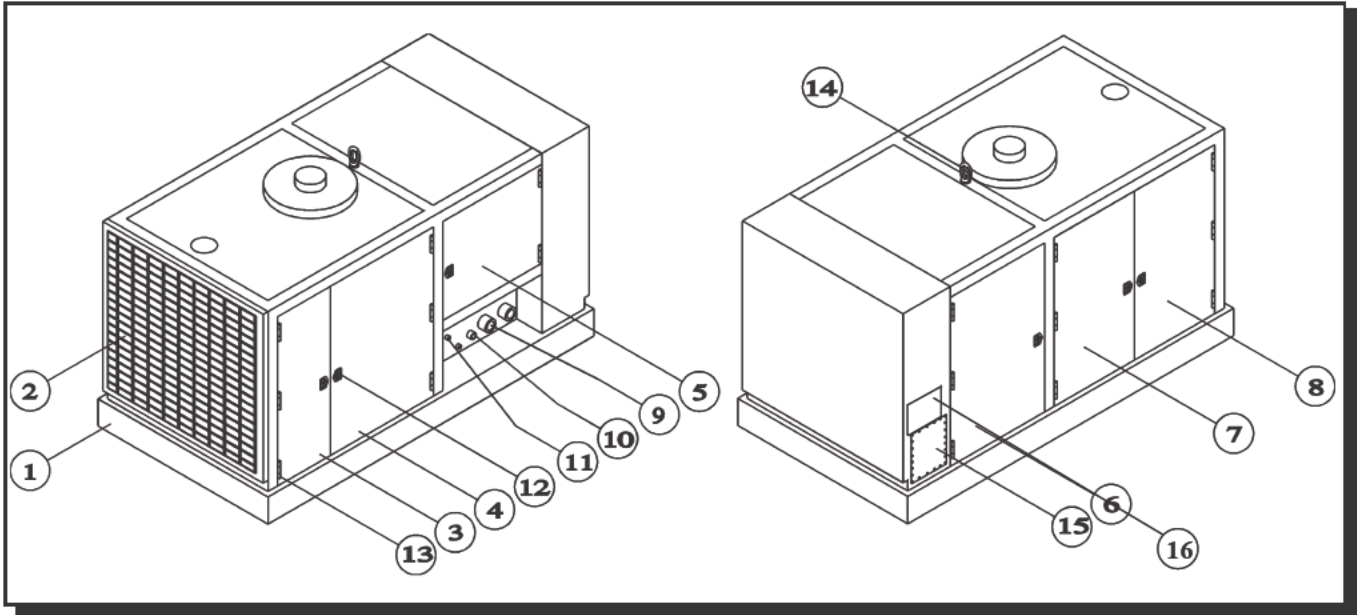

Figure 2-F. Model 700VM Power Unit Skid Identification.

Item	Qty	Description	Part No.
1	1	Model 700VM Power Unit Skid	
2	1	Radiator Grill	
3	1	Door 27 1/2" x 67 1/2"	
4F	1	Door 23 5/8" x 67 1/2"	
4R	1	Door 23 5/8" x 67 1/2"	
5	1	Door 33 1/2" x 36"	
6	1	Door 33 1/2" x 67 1/2"	
7F	1	Door 23 5/8" x 67 1/2"	
7R	1	Door 23 5/8" x 67 1/2"	
8	1	Door 27 1/2" x 67 1/2"	
9A	1	1-1/2" Hyd. Quick Disconnect Female"REV"	
9B	1	1-1/2" Hyd. Quick Disconnect Male "FWD"	
10A	1	3/4" Hyd. Quick Disconnect Female Phase Case Drain	421019
10B	1	1" Hyd. Quick Disconnect Female Vibro Case Drain	555151
11A	1	3/8" Hyd. Quick Disconnect Female Clamp ""	421024
11B	1	3/8" Hyd. Quick Disconnect Male Clamp ""	421025
11C	1	3/8" Hyd. Quick Disconnect Male Drill Shift	555155
11D	1	1/2" Hyd. Quick Disconnect Female Phase "OUT"	555159
11E	1	1/2" Hyd. Quick Disconnect Male Phase "IN"	555161
12	6	Lock-#EMC 56462W Two Point Lock Handle-#EMC 48742W Locking Handle	
13	17	Hinges #R140-150 Weld On Hinge	
15	2	Access Cover Plate 18" x 21"	
16	1	Access Cover Plate 12" x 15"	

II. MAJOR COMPONENT DEFINITION (Continued...)

II-7. Quick Disconnect Couplings.

The APE Quick Disconnect Couplings are high pressure hydraulic couplings designed for rugged applications. Service in many such applications has proven the design compatible to extreme pressures, structural and system induced shock loads. The construction of the coupling assembly promotes ease of use and maintenance.

Design Features:

- Excellent flow characteristics for continuous duty applications.
- High strength design endures high surge and shock conditions.
- Flat crested stub-ACME threads and all steel construction withstand storage and rig-up damage.
- Structurally compatible with weight of 5,000 P.S.I. flex-hose and system induced shockloads.

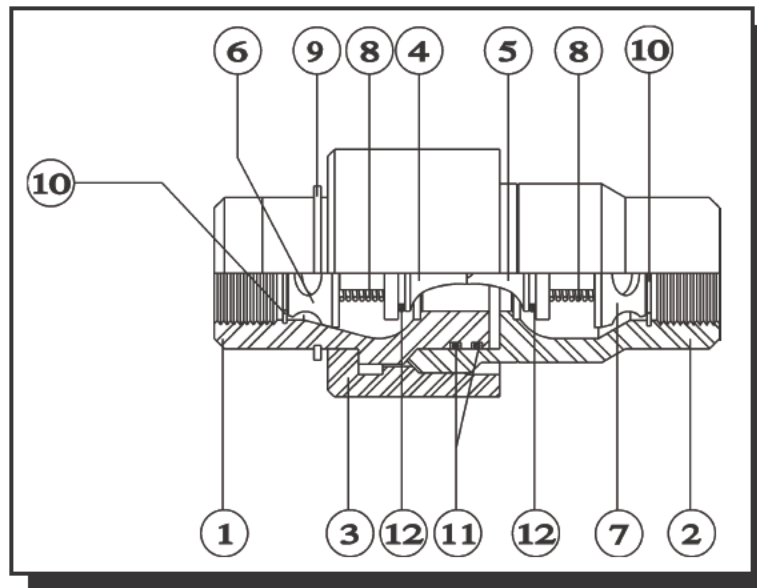

Figure 2-H. Quick Disconnect Coupling Identification.

Item	Qty	Description
1	1	Q.D. Hydraulic Female Coupling #400301
2	1	Q.D. Hydraulic Male Coupling #400303
3	1	Q.D. Hydraulic Coupling Sleeve #400302
4	1	Q.D. O-Ring Carrier "A" #400202
5	1	Q.D. O-Ring Carrier "B" #400201
6	1	Q.D. Plunger #400101
7	1	Q.D. Plunger #400101
8	1	Q.D. Plunger Spring #400701
9	1	Retaining Ring - "Inverted External" #I-275
10	2	Retaining Ring - "Truarc Internal" #N5000-168
11	2	Parker O-Ring #2-230 & One Parback
12	2	Parker O-Ring #2-216



OPERATION / MAINTENANCE MANUAL

MODEL 250VM VIBRATORY DRIVER WITH MODEL 700VM POWER UNIT

7032 SOUTH 196th - KENT, WA. 98032 - (253) 872-0141 / FAX (253) 872-8710

II. MAJOR COMPONENT DEFINITION (Continued...)

II-8. Tool Set Identification.

Mounted inside the **Model 700V Power Unit** is a set of tools frequently used for the maintenance of the **APE Model 250V Vibratory Driver**. The following figure and table shows the location and the use for each tool.

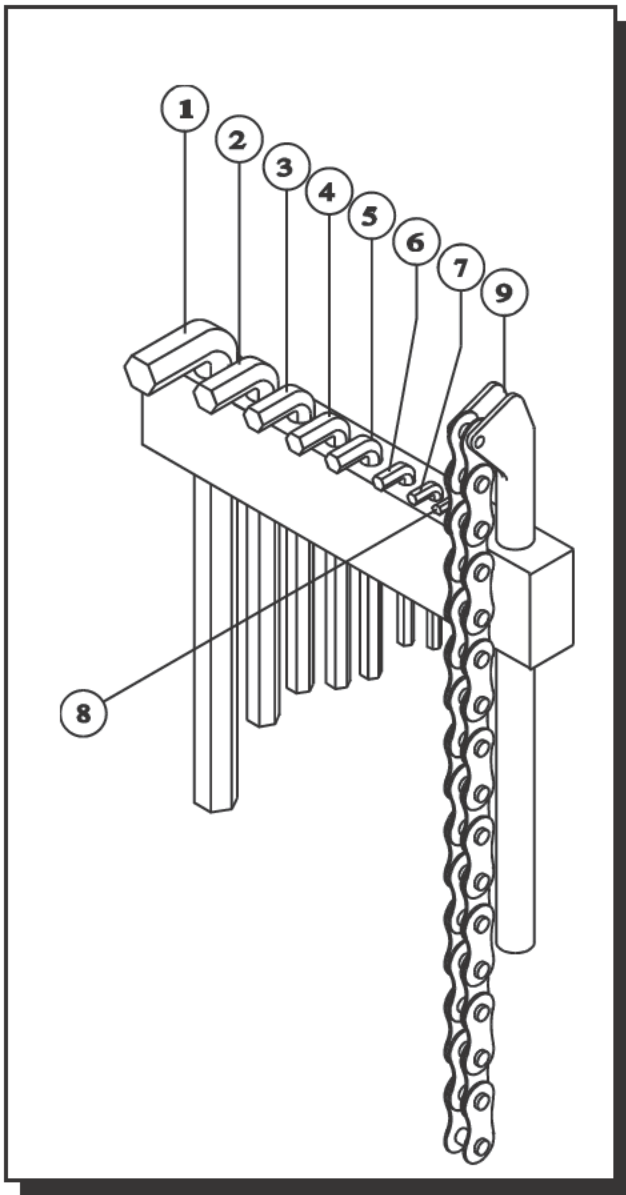

ITEM	QTY	DESCRIPTION	PART#
1	1	1" Allen Wrench	#50004
For use with the clamp attachment bolts			
2	1	3/4" Allen Wrench	#50006
For use with clamp fixed jaw, sheet guide			
3	1	5/8" Allen Wrench	#95007
For hydraulic motor, drain plug, top plate			
4	1	9/16" Allen Wrench	#50013
For use with the hose bracket bolts			
5	1	1/2" Allen Wrench	#50008
6	1	3/8" Allen Wrench	#50009
For use with bearing cover bolts			
7	1	5/16" Allen Wrench	#50014
For use with the hose bracket bolts			
8	1	1/4" Allen Wrench	#50015
For use with the vibro oil level check			
9	1	Chain Wrench	#50011
Used to tighten the quick disconnects			

Table 2-I. Tool Set Identification.

Figure 2-I. Tool Set Identification.



OPERATION / MAINTENANCE MANUAL

MODEL 250VM VIBRATORY DRIVER WITH MODEL 700VM POWER UNIT

7032 SOUTH 196th - KENT, WA. 98032 - (253) 872-0141 / FAX (253) 872-8710

II. MAJOR COMPONENT DEFINITION (Continued...)

II-9. Caisson Clamp Identification.

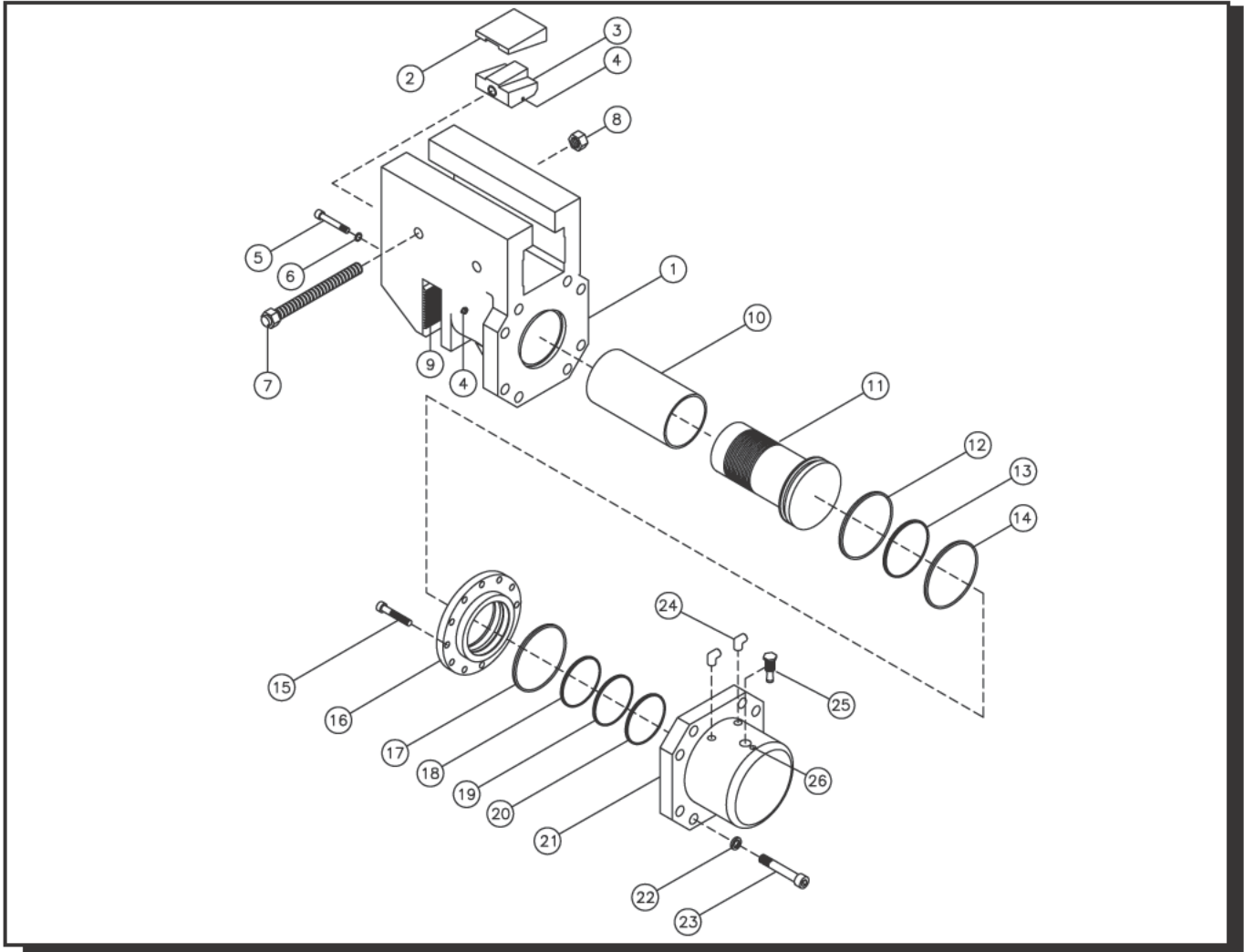

Figure 2-J. Caisson Clamp Identification.

Item	Qty	Description	Part #
1	1	Caisson Clamp Body	#250101
2	2	Male Wedge Half (Bronze)	#243102
3	2	Female Wedge Half (Steel)	#24310516
4	6	Grease Zert	#221001
5	2	Bolt - SHCS 5/8" x 4"	#12421418
6	2	Lock Washer 5/8" High Collar	#124115
7	2	Wedge Bolt w/Washer	#124211
8	2	Wedge Nut w/Washer	#124212
9	1	Caisson Clamp Fixed Jaw #250202	
10	1	Plastic Sleeve	#250224
11	1	Piston Rod	#250003
12	1	O-Ring R-5100-128	#222010
13	1	Expander #442	#222010

Item	Qty	Description	Part #
14	1	Molygard 8000	#222010
15	12	Bolt SHCS 5/8 NF (Machined)	#124209
16	1	Cylinder Gland	#222302
17	1	O-Ring 2-367	#222010
18	1	Wiper Seal 959-53	#222010
19	1	Polypak 6000	#222010
20	1	Molygard 6250	#222010
21	1	Clamp Cylinder	#222001
22	8	1-1/4" High Collar Lock Washer	#124205
23	8	Bolt - SHCS 1-1/4" NF x 4.00	#124204
24	2	#6 SAE - #6 JIC 45 deg Fitting	#222002
25	1	Check Valve	#222016
26	1	#6 SAE Allen Plug	#222017

Table 2-J. Caisson Clamp Identification

II. MAJOR COMPONENT DEFINITION (Continued...)

II-10. Control Panel and Parts.

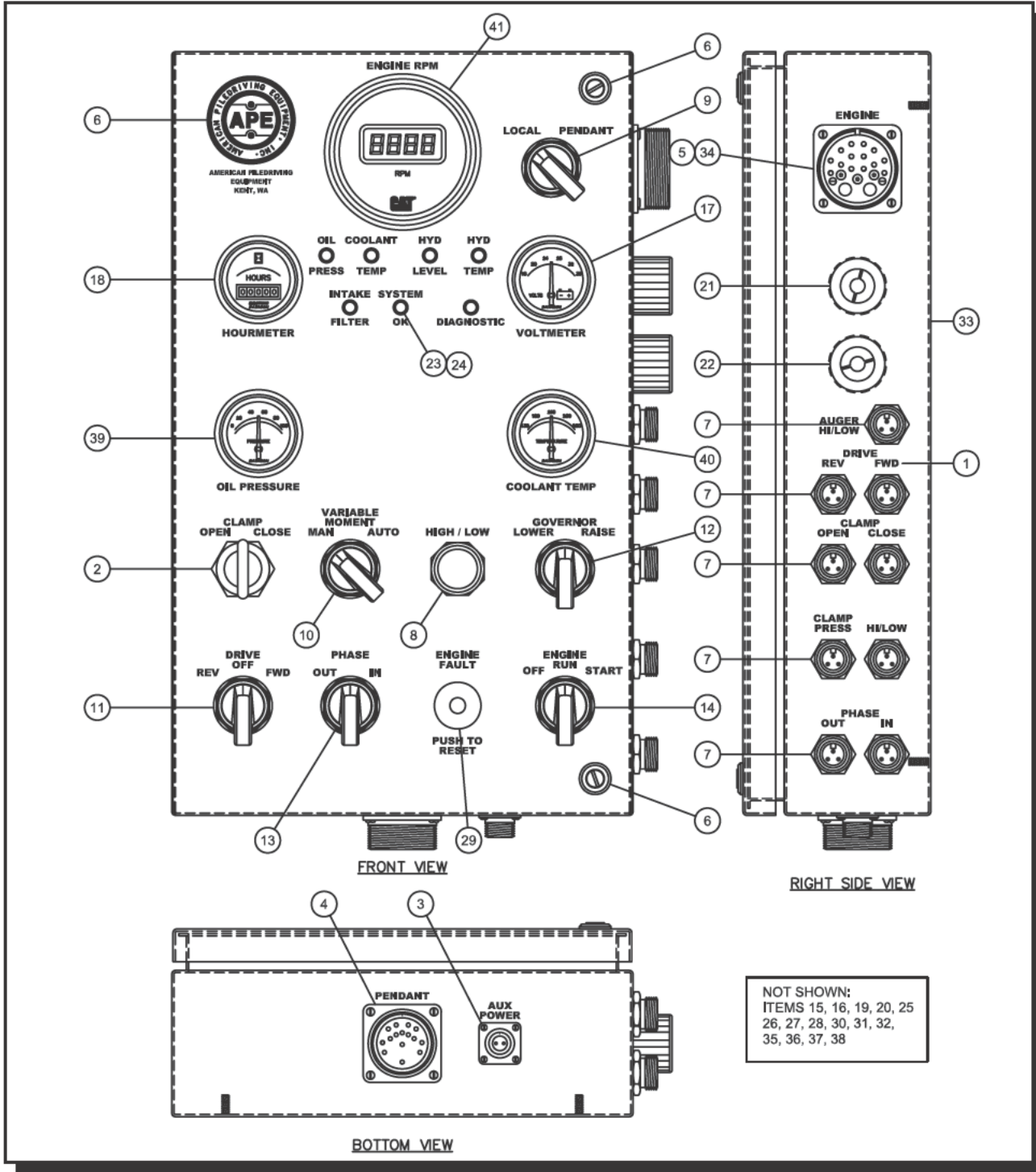

Figure 2-K. Control Panel Front View.



OPERATION / MAINTENANCE MANUAL

MODEL 250VM VIBRATORY DRIVER WITH MODEL 700VM POWER UNIT

7032 SOUTH 196th - KENT, WA. 98032 - (253) 872-0141 / FAX (253) 872-8710

II. MAJOR COMPONENT DEFINITION (Continued...)

<u>ITEM</u>	<u>DESCRIPTION</u>	<u>QTY</u>	<u>PART BREAKDOWN</u>	<u>MFG.</u>	<u>MFG. PART #</u>
1	S.O. Cord Description	1	Side Legend Plates	AAA	
2	Lighted Clmp. Open/Cl. Sw.	1	Illuminated 3-Pos. Spr. Ret. from L	A-B	3700SP11
		1	Diode	I/R	606S
3	Auxiliary Pwr. Receptacle	1	PM 2-socket Aux. Receptacle	Amphenol	MS3102A-12S-3-S
		1	PM Aux Receptacle Gasket	Amphenol	10-40450-12
		1	PM Aux Receptacle Cover	Amphenol	MS25043-12D
4	Pendant Receptacle	1	PM 15 Socket Pendant Receptacle	Amphenol	MS3102A28-17S
		1	PM Pen Receptacle Gasket	Amphenol	10-40450-28
		1	PM Pen Receptacle Cover	Amphenol	MS25043-28D
		1	PM 23-Pin Engine Receptacle	Amphenol	MS3102A32-
5	Engine Receptacle	1	PM Engine Receptacle Gasket	Amphenol	10-40450-32
6P		1	VM 350 M11 Door Silk Screen	ASP	VM350DSS
6	SS Door Silk Screen	2	Door Hardware		
		8	Side PM Male Receptacle	Brad Harrison	1R3006A24A120
7	PM S.O. Cord Hookups	8	1/2" Lock Nut	Regal	801
		1	Push Button	C-H	10250T101
8	High/Low Push Button	1	Contact Block	C-H	10250T2
		1	2-Position Operator (Maint.)	C-H	10250T3011
9	Local/Pendant Switch	2	Contact Block, 2 N.O. / 2 N.C.	C-H	10250T44
		1	2-Position Operator (Maint.)	C-H	10250T3011
10	Variable Moment Switch	2	Contact Block, 2 N.O. / 2 N.C.	C-H	10250T44
		1	3-Position Operator (Maint.)	C-H	10250T3023
11	Drive Rev/Fwd Switch	1	Contact Block, 2 N.O.	C-H	10250T2
		1	Contact Block, 2 N.C.	C-H	10250T3
		2	Diode	I/R	606S
		1	3-Position Operator (Mom.)	C-H	10250T3043
12	Governor Lower/Raise Sw.	1	Contact Block, 2 N.O.	C-H	10250T2
		1	3-Position Operator (Mom)	C-H	10250T3043
13	Phase In/Out Switch	1	Contact Block, 2 N.O.	C-H	10250T2
		1	3-Position Operator (Maint/Mom)	C-H	10250T3053
14	Engine Control Switch	1	Contact Block	C-H	1 10250T1
		1	Timer: Multifunction, 24VDC	Crouzet	ORCR1 88 867 135
15	TD2	1	Timer Socket	Idec	SR2P-06
		1	Timer: Multifunction, 24VDC	Crouzet	ORCR1 88 867 215
16	TD1	1	Timer Socket	Idec	SR2P-06
		1	Voltmeter Gauge	Datcon	100161
17	Volteter Gauge	1	Voltmeter Gauge	Datcon	100223
18	Hourmeter Gauge	1	Hourmeter Gauge	Datcon	100223
19	Speed Switch	1	Speed Switch	ECU	ECU-SS40
20	Drive Rev/Fwd Hourmeter	1	Drive Hourmeter	Hobbs	85094-12
		1	Drive Hourmeter Bracket	Hobbs	23944
21	Cord Connector	1	3/4"-3/8"-1/2" Cord Connector	Hubbell	SHC1035CR
		1	3/4" Lock Nut	Regal	802
		1	3/4" Rubber Gasket	T&B	5303
22	Cord Connector	1	3/4" Cord Connector	Hubbell	SHC1036CR
		1	3/4" Lock Nut	Regal	802

Table 2-K. Control Panel Parts.



OPERATION / MAINTENANCE MANUAL

MODEL 250VM VIBRATORY DRIVER WITH MODEL 700VM POWER UNIT

7032 SOUTH 196th - KENT, WA. 98032 - (253) 872-0141 / FAX (253) 872-8710

II. MAJOR COMPONENT DEFINITION (Continued...)

II-10. Control Panel and Parts (Continued...)

Table 2-J. Control Panel Parts (Continued...)

<u>ITEM</u>	<u>DESCRIPTION</u>	<u>QTY</u>	<u>PART BREAKDOWN</u>	<u>MFG.</u>	<u>MFG. PART #</u>
23	Panel Alarm Lights	5	Red L.E.D.	Idec	AP8M222-R
24	System OK Light	1	Green L.E.D.	Idec	AP8M222-G
25	Panel Terminal Blocks	1	Terminal Block End Piece	Idec	BNE15W
		3	Terminal Block	Idec	BNH15LW
		44	Terminal Block	Idec	GNH15MW
		2	Terminal Block End Clips	Idec	BNL5
		14	Diode	I/R	60S6
26	Oil Press. Lockout Relay	1	2-Pole Lighted Relay	Idec	RH2BUL-24VDC
		1	2-Pole Relay Base	Idec	SH2B-05C
27	Governor Lower Relay	1	2-Pole Lighted Relay	Idec	RH2BUL-24VDC
		1	2-Pole Relay Base	Idec	SH2B-05C
28	High/Low Relay	1	2-Pole Lighted Relay	Idec	RH2BUL-24VDC
		1	2-Pole Relay Base	Idec	SH2B-05C
29	Engine Fault Switch	1	Magnetic Switch	Murphy	117PH
30	10 Amp Circuit Breaker	1	Circuit Breaker, 10 Amp	Siemens	5SX2110-8
31	Tachometer Transducer	1	Tachometer Transducer	Red Lion	IFMA0035
32	Rubber Stand Offs	4	Shock Mount Legs (1/4")	Vib. Elim.	40B
33	SS Enclosure Back Pan	1	SS Enclosure Back Pan	Vulcan	Stainless
34	Engine Plug	1	CM 23 Socket Engine Receptacle	Amphenol	MS3106A32-6S
		1	CM Engine Receptacle Clamp	Amphenol	MS3057-20A
35	Eng. Mount Fem. Receptacle	1	Eng. Mount Fem. Receptacle	Brad Harrison	1R3004A20A120
36	4 M Yellow S.O. Cord	7	4 M Yellow S.O. Cord	Brad Harrison	103000A02F120
37	4 M Double-Ended S.O. Cord	1	4 M Double-Ended S.O. Cord	Brad Harrison	113022A01F120
38	Shock Mount Foot	2	Shock Mount Foot	Vib. Elim.	T22-3
39	Oil Pressure Gauge	1	Oil Pressure Gauge	Murphy	20P100
40	Coolant Temperature Gauge	1	Water Temperature Gauge	Murphy	20T25010
41	Engine RPM Gauge	1	Engine RPM Gauge		Caterpillar
197-7348					

II. MAJOR COMPONENT DEFINITION (Continued...)

II-10. Control Panel and Parts (Continued...)

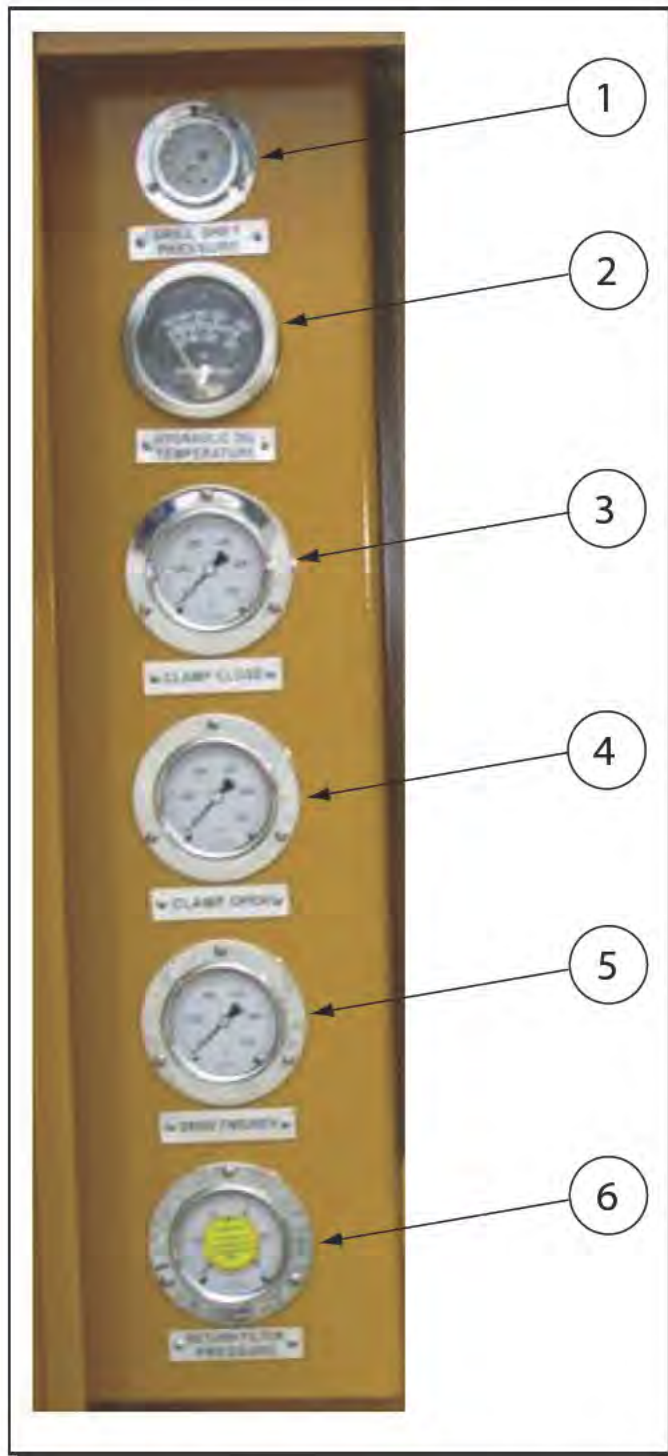

<u>ITEM</u>	<u>APE P/N</u>
1. DRILL SHIFT PRESS.	555051
2. OIL TEMP. GAGE	523016
3. CLAMP CLOSE GAGE	513007
4. CLAMP OPEN GAGE	513007
5. DRIVE GAGE	513007
6. RET. FILTER PRESS.	513007A

Table 2-L. Control Panel-Gages.

Figure 2-L. Control Panel-Gages.

II. MAJOR COMPONENT DEFINITION (Continued...)

II-11. Control Pendant and Parts.

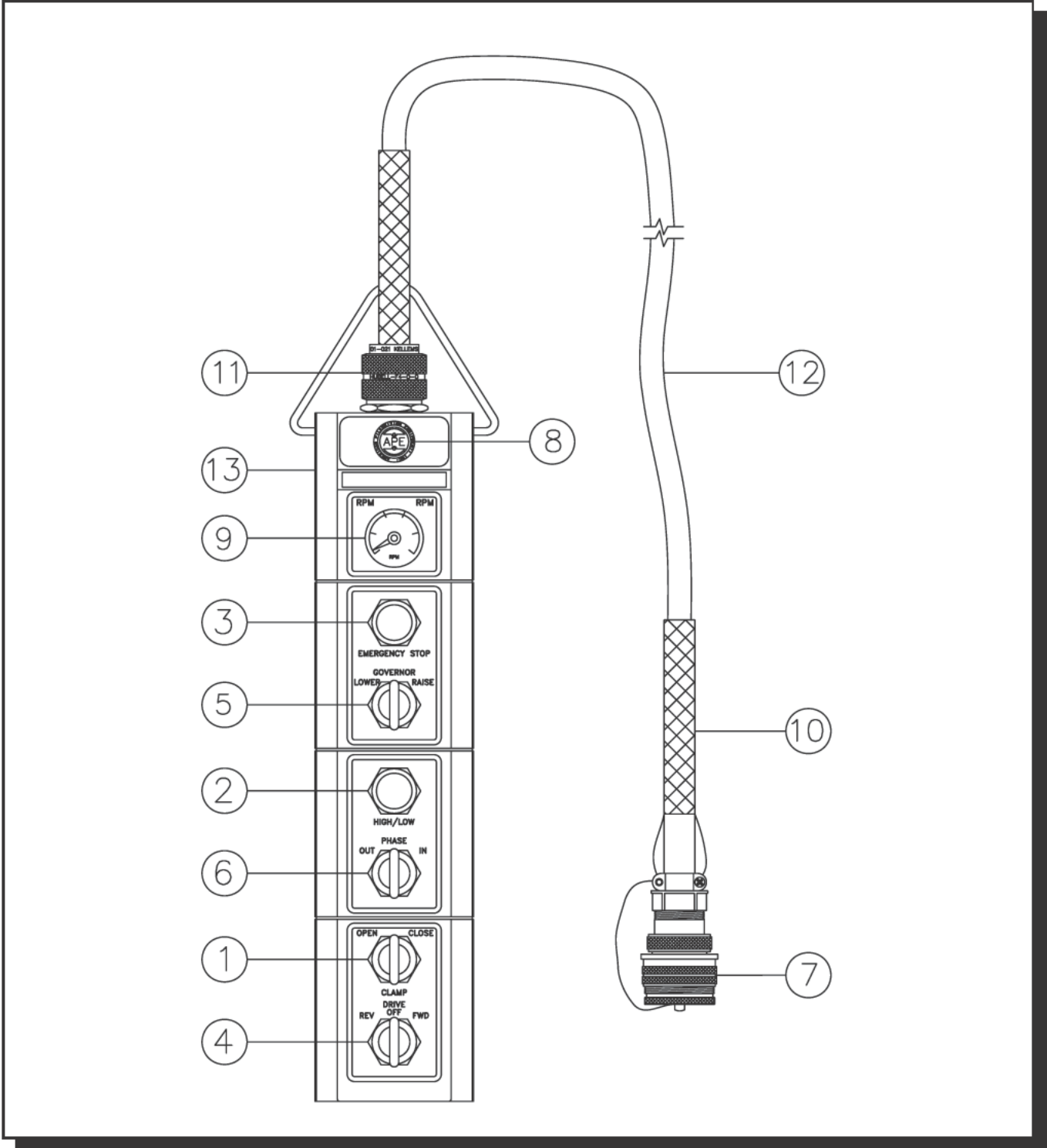

Figure 2-M. Control Pendant and Parts.



OPERATION / MAINTENANCE MANUAL

MODEL 250VM VIBRATORY DRIVER WITH MODEL 700VM POWER UNIT

7032 SOUTH 196th - KENT, WA. 98032 - (253) 872-0141 / FAX (253) 872-8710

<u>Item #</u>	<u>QTY.</u>	<u>DESCRIPTION</u>	<u>PART DESCRIPTION</u>	<u>MFG.</u>	<u>MFG. PART #</u>
1	1	Illum. 3 Pos. Spr Ret From L	Clamp Open/Close Sw.	A-B	800T-24JG4KB7AX60S6
	1	Diode	Diode	I/R	60S6
2	1	Flush Head Black PB 1 n.o.	High/Low Push Button	A-B	800T-A2D1
3	1	Flush Head Red PB 1 n.o.	Emergency Stop PB	A-B	800T-A6D1
4	1	3 Pos. Maintained Switch	Drive Rev/Fwd Switch	A-B	800T-J2KC1
	1	Contact Block 1N.O./N.C.	Contact Block, 1N.O./N.C.	A-B	800T-XA
	2	Diode	Diode	I/R	60S6
5	1	3 Pos. Spr. Ret. From Both	Governor Lower/Raise Sw.	A-B	800T-J91A
6	2	3 Pos. Spr. Ret. From Both	Phase In/Out Switch	A-B	800T-J91A
7	1	CM Pen Plug Cover	CM Pen Plug Cover	Amphenol	MS25042-28D
	1	CM Pendant Plug Clamp	CM Pendant Plug Clamp	Amphenol	MS3057-16A
	1	CM 15 Pin Plug	CM 15 Pin Plug	Amphenol	MS3106A28-17P
8	1	Var. Mom. Decal Set of 5	Logo & Switch Descr.	ASP	VMDS5
9	1	Analog Meter 0-2500 rpm	RPM Gauge	Crompton	082-80R2-215256
	1	Diode	Diode	I/R	60S6
10	1	Kellems Grip	Cable Mount Plug Grip	Hubbell	073-10-003
11	1	Deluxe Cord Grip	Pendant Mount Cord Grip	Hubbell	074-01-021
12	50	16 Awg 16 Con. Pend. Cbl.	16 Awg 16 Con. Pend. Cbl.	Perfaflex	F19061616
13	1	6 Unit Pendant Box	6 Unit Pendant Box	Square-D	9001-SKYP-6

Table 2-M. Control Pendant and Parts.



OPERATION / MAINTENANCE MANUAL

MODEL 250VM VIBRATORY DRIVER WITH MODEL 700VM POWER UNIT

7032 SOUTH 196th - KENT, WA. 98032 - (253) 872-0141 / FAX (253) 872-8710

III. LOADING AND UNLOADING

III-1. Model 250VM Vibratory Driver.

The APE 250VM vibrators are normally shipped in travel stands. Two sliding pins release the vibrator from the stand. To re-install, set vibro in stand and slide pins inward and rotate. Hoist vibro and stand by rigging to the vibro lifting shackle. Vibrators shipped without stands are usually laid flat on the trailer deck and the hose bundle is coiled on top. Lift the vibrator by rigging one line to the lifting shackle and one line around the clamp attachment lifting the vibro and hose bundle as one load. Avoid smashing hydraulic lines. Vibro should be loaded with hydraulic motors down facing the deck and breather valves facing the sky. Before the truck has left, carefully inspect the machine and hoses for any missing equipment or sign of damage that may have occurred during shipment or unloading.

III-2. Model 700VM Power Unit.

The Power Unit is always loaded with the oil cooler facing to the rear of the truck to prevent damage to the cooler and the radiator from flying objects. The Power Unit is usually held to the truck by wrapping a chain around both ends of the fuel tank base and the truck bed. After loading the Power Unit, tape the exhaust rain cap shut to prevent rain water from getting inside. If quick disconnects do not have safety cables then store them under the panel in the storage box rather than risk the possibility of the caps and plugs coming loose and falling off into traffic. Make sure all doors are fully closed. Tighten fuel vent on the fuel cap to prevent diesel fuel from washing out the fill spout.

III-3. What to do if damaged during shipment.

In the event of damage, notify the trucking agent at once. Note all damage on the bill of lading. Fax the information as soon as possible, any delay may make it impossible to find the responsible party.



OPERATION / MAINTENANCE MANUAL

MODEL 250VM VIBRATORY DRIVER WITH MODEL 700VM POWER UNIT

7032 SOUTH 196th - KENT, WA. 98032 - (253) 872-0141 / FAX (253) 872-8710

IV. PREPARATION AND OPERATION

IV-1. Rigging of Vibratory Driver

A steel wire rope sling must be connected to the lifting bail located on top of the vibro. The required strength of this sling depends on the capacity of the crane and the work to be carried out. A safety factor of six is recommended. Several turns of a smaller diameter cable will result in a longer lasting sling than one larger diameter cable. When making a sling, avoid using cheap cable clamps. Check the clamps daily.

IV-2. Installing the Clamp Attachment

The Vibro is fitted with a standard sheet clamp at the factory. However, several types of clamps are used on APE vibros to fit many different types of piles. A step by step procedure is provided as follows:

- 1.) Clean all drilled and tapped threads on the bottom surface of the gearbox. Use a 1 1/2"UNC tap to clean any rusted threads and blow out any remaining fragments with compressed air. If there is a cutting torch on the jobsite then use the oxygen setting to blast the threads clean. Hold a rag over the tapped hole to prevent flying dirt from blasting into your eyes.
- 2.) Clean the machined bottom surface of the gearbox and prepare to mount the clamp. If the clamp bolts should ever break, check the machined surface with a straight edge to make sure it is true and flat.
- 3.) Clean the machined surface of clamp. Eye-ball the entire surface for damage. Make sure the surface is flat and void of all dirt.
- 4.) Start by getting the center bolt in first and work outwards. Do not tighten bolts until you have all of the bolts started.
- 5.) Tighten bolts using a six-foot cheater pipe. If you do not have a cheater pipe then use a sledge hammer.
- 6.) Go around all bolts at least three times making sure they are tight.
- 7.) After vibrating the first pile, check the bolts again.
- 8.) If one bolt breaks, replace them all since they may be weak or cracked.
- 9.) Never operate the vibro with missing clamp bolts.

WARNING: Do not use grade five bolts. All bolts should be allen head cap screw bolts. If one bolt breaks then the others are damaged and must be replaced. Never drive piles if one bolt is broken. Bolts break only because they were not tight and the crew neglected to check them. A good operator insists that every bolt is checked twice daily.

IV. PREPARATION AND OPERATION (Continued...)

IV-3. Plumbing the Vibro Hoses to the Power Unit.

There are eight hoses leading from the vibro that must be connected to the power unit to begin operation (Please see section II-5, "Hose Identification, page 2-5.) The hoses attach to the power unit by screwing the quick dis-connect couplers onto the proper couplers of the power unit. The couplers on the power unit are mated with the couplers on the vibro so there is no chance of putting them on backwards. Please take the following steps when installing the couplers:

WARNING: TURN THE POWER UNIT OFF BEFORE INSTALLING COUPLERS

- 1.) Turn the power unit OFF.
- 2.) Clean all couplers with a can of ether if available. A clean dry cloth will also work but will require extreme care. Fittings must be spotless clean.
- 3.) Install couplers by screwing them onto their respective counterparts. Try to avoid cross-threading and maintain a straight line. Jerk the hose back and forth while turning coupler to aid installation effort. **Push hard to get the big coupler threads started.**
- 4.) Make sure fittings are tight. If they are properly cleaned they should run up tight with just a firm hand grip. However, they should be double checked with a chain wrench.
- 5.) Avoid over-tightening.
- 6.) If near salt water, spray with a light oil to prevent oxidation.
- 7.) Position the Power Unit so that vibrator has enough hose to reach the work. Avoid pulling too hard on hoses. Most hose failures are caused by pulling hoses off couplers.

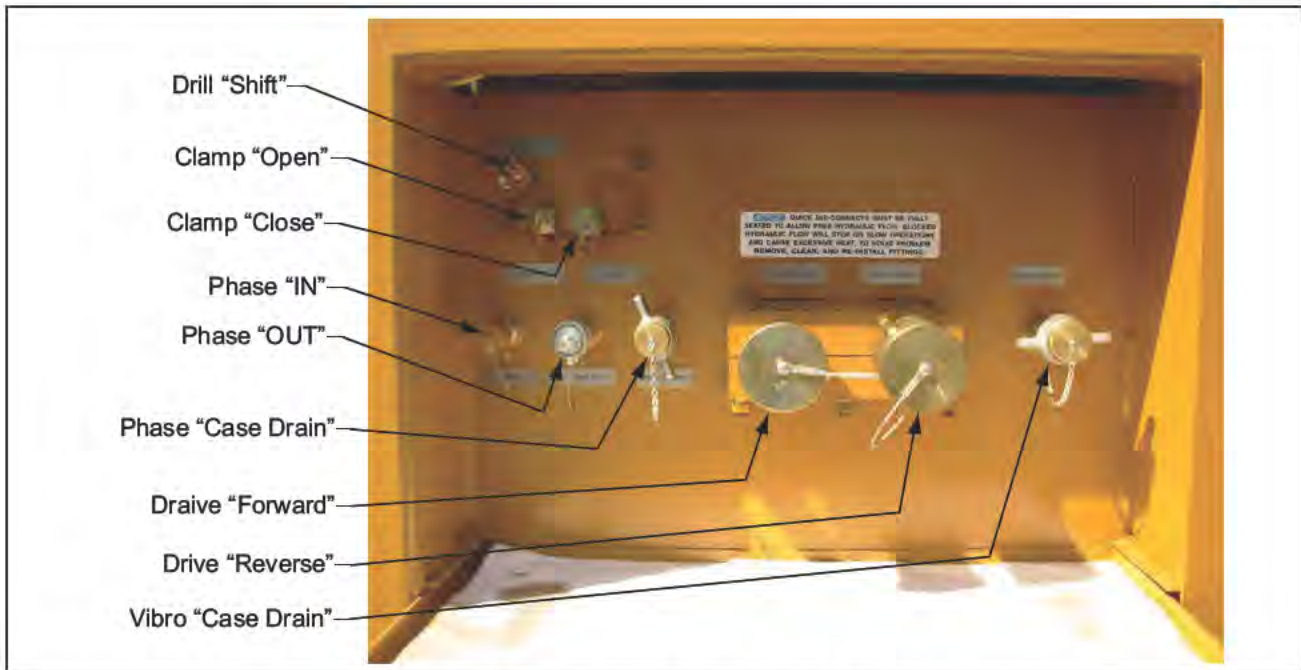

Figure 4-A. Power Unit Hose Plumbing

IV. PREPARATION AND OPERATION (Continued...)

IV-4. Filling Vibrator Pressure Hose.

The vibrator is shipped with the hoses filled with oil. However, if the unit has been sitting for a long period of time or if a damaged hose has been replaced with a new one, then the hoses must be filled. Hook up all the hoses to the power unit (see Section IV-3 on [page 4-2] and Figure 4-A.). Start the power unit and let it run for ten minutes before running the vibro. The hoses will fill up by themselves in ten minutes even if the vibro is not in the vibrate mode.

IV-5. Bleeding the Clamp Attachment Hydraulic Hoses.

If the opening and closing of the jaws seems spongy or slow, it may be a result of air in the clamp hoses. Normally there is no need to worry about bleeding the clamp lines because the unit is shipped fully tested. However, should the vibro sit for a long period of time, if a new attachment is being installed or if a damaged clamp hose has been replaced, then the system may require bleeding to remove unwanted air in the system. To bleed the clamp system, follow the following steps:

- 1.) Shut Power Unit OFF.
- 2.) Make sure the clamp line quick dis-connects are coupled to the power unit.
- 3.) Start the power unit engine and run at 1500 rpm. Give the engine time to warm up.
- 4.) Loosen the clamp lines at the hydraulic cylinder by backing the fittings off just a little.
- 5.) Turn the clamp switch on the power unit control pendant to "CLOSE" and wait for oil to flow from the fittings. WATCH FOR AIR BUBBLES. When air bubbles have stopped then quickly re-tighten the fittings.
- 6.) Repeat the same procedure for "OPEN" side.
- 7.) Operate the jaws. If they are still a bit spongy then repeat bleeding steps once more.

WARNING: DO NOT BLEED SYSTEM AT FULL ENGINE THROTTLE BECAUSE TOO MUCH OIL WILL FLOW FROM THE HOSES AND COULD CAUSE INJURY.

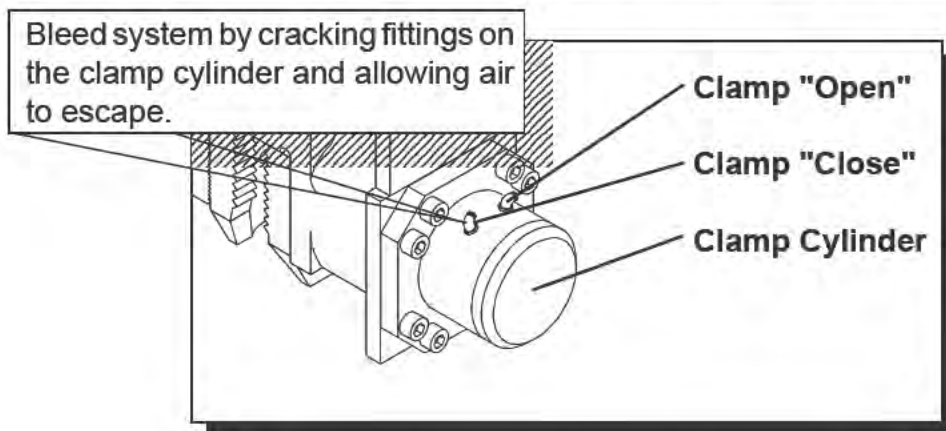

Figure 4-B. Bleeding Clamp Attachment



OPERATION / MAINTENANCE MANUAL

MODEL 250VM VIBRATORY DRIVER WITH MODEL 700VM POWER UNIT

7032 SOUTH 196th - KENT, WA. 98032 - (253) 872-0141 / FAX (253) 872-8710

IV. PREPARATION AND OPERATION (Continued...)

IV-6. Precautions and Rules for Operation.

The following is a list of precautions, suggestions and rules that are intended to help promote the safe and productive use of the APE Model 250VM Vibratory Driver.

- 1.) Follow the Daily Maintenance Required Prior to Operation, [Section V-1].
- 2.) Read and follow the Safety Precautions, [page iii].
- 3.) Follow the start-up procedures listed in the manual for the power unit being used.
- 4.) Start with piles in good condition.
- 5.) Put all teeth in pile.
- 6.) Drive in steps eight feet (2.5M) or less.
- 7.) Keep sheets plumb.
- 8.) Come up to speed before doing work.
- 9.) No dancing. Avoid densifying the soil.
- 10.) Drive past obstacles and then go back.
- 11.) Backhoe on site to remove obstacles.
- 12.) Lead with the ball.
- 13.) Probe the pile if it appears stuck.
- 14.) Keep piles plumb or down the road you go.
- 15.) Never rush the sheet pile foreman.
- 16.) Slow and plumb and the job will get done.
- 17.) Melted inner locks - piles out of plumb.
- 18.) Never stand under pile drivers.
- 19.) Low clamp pressure means jaw failures.
- 20.) Wait for vibro to get to full speed then pull.
- 21.) Don't over excavate - lower the ring.
- 22.) Look at the jaws during driving.
- 23.) Beware of cracked or broken sheets.
- 24.) In sandy soils drive faster. Vibration can cause settlement in loose, granular soils.
- 25.) In clay amplitude is everything.
- 26.) Low drive pressure means easy work.
- 27.) High pressure means friction on piles.
- 28.) Over 5000 psi means get a bigger vibro.
- 29.) No amplitude means get a bigger vibro.
- 30.) Caissons need heavy wall to avoid flex.
- 31.) Check clamp bolts each morning.
- 32.) Read the manual - know your machine.
- 33.) Attach whip line to pile when pulling.
- 34.) Know your line pull.
- 35.) Extract straight - look at boom and cable.
- 36.) Give boom stops some room.
- 37.) Stalled engine means dirty fuel filters.

IV. PREPARATION AND OPERATION (Continued...)

IV-7. Relief Valve Settings Prior to Operation - Model 700VM

The Relief Valve and Pressure Switches are set by the factory. They will need to be re-set if the pressure switch is replaced.

1. Do not hook up quick disconnects. Start and warm engine . Bring to full rpm.
2. Check Clamp relief valve setting. On the Control Panel, turn the clamp switch to "OPEN" and hold it there while you read the CLAMP OPEN GAUGE on the panel. It should read 4800 PSI. If it is not coming up to pressure, then set the relief valve (FACTORY AUTHORIZED PERSONNEL ONLY), by loosening the lock nut and turning the knob in slowly until the proper pressure is reached. Turn in (CW) to increase pressure, and out (CCW) to decrease pressure. Tighten the locknut and recheck the pressure to make sure that the setting did not move during tightening the lock nut. When the clamp switch is turned to "OPEN" and held, a small light on the solenoid is illuminated, showing that there is power to the solenoid. Otherwise, the light on the solenoid should be off.

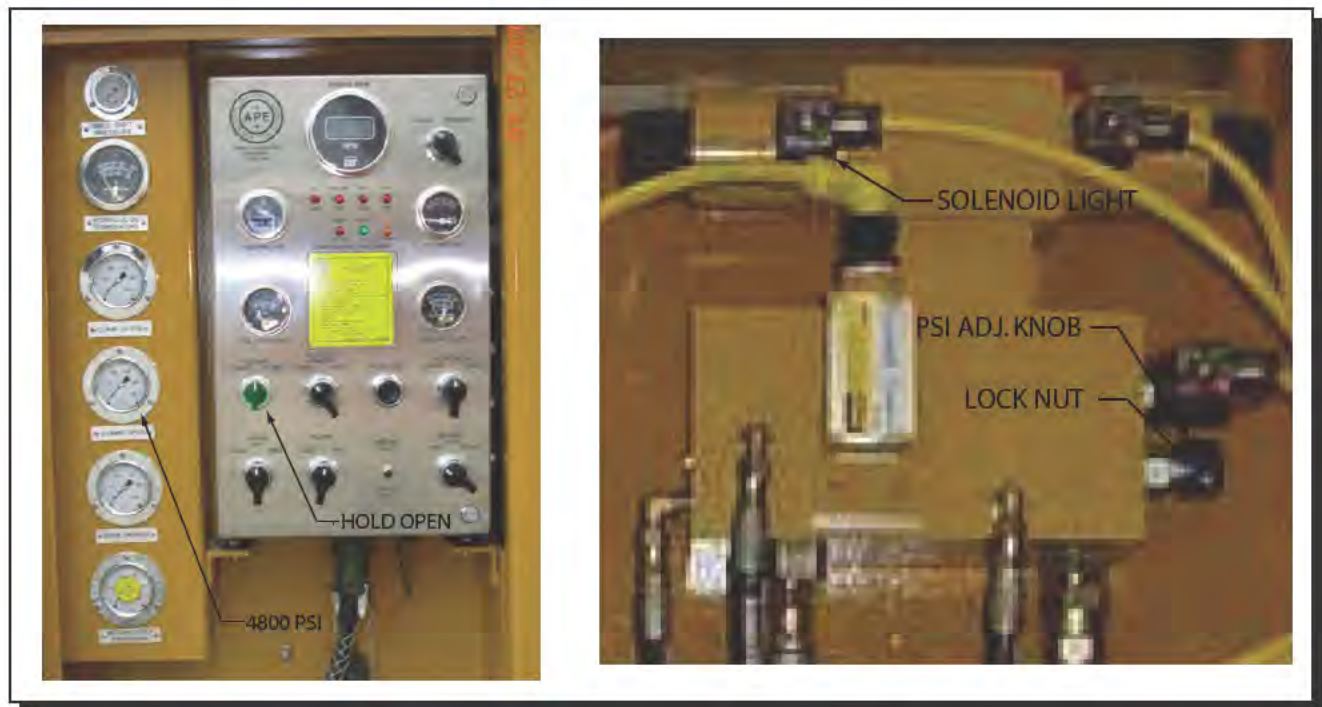

Figure 4-C. Setting Relief Valve

IV. PREPARATION AND OPERATION (Continued...)

IV-7. Relief Valve Settings Prior to Operation - Model 700VM (Continued...)

3. Check the clamp pressure switch setting. Turn the clamp to "CLOSE". If there is proper clamp pressure the CLAMP CLOSE GAUGE should read 4500 PSI to 4800 PSI, and the GREEN LIGHT comes on (see figure 4-D.)

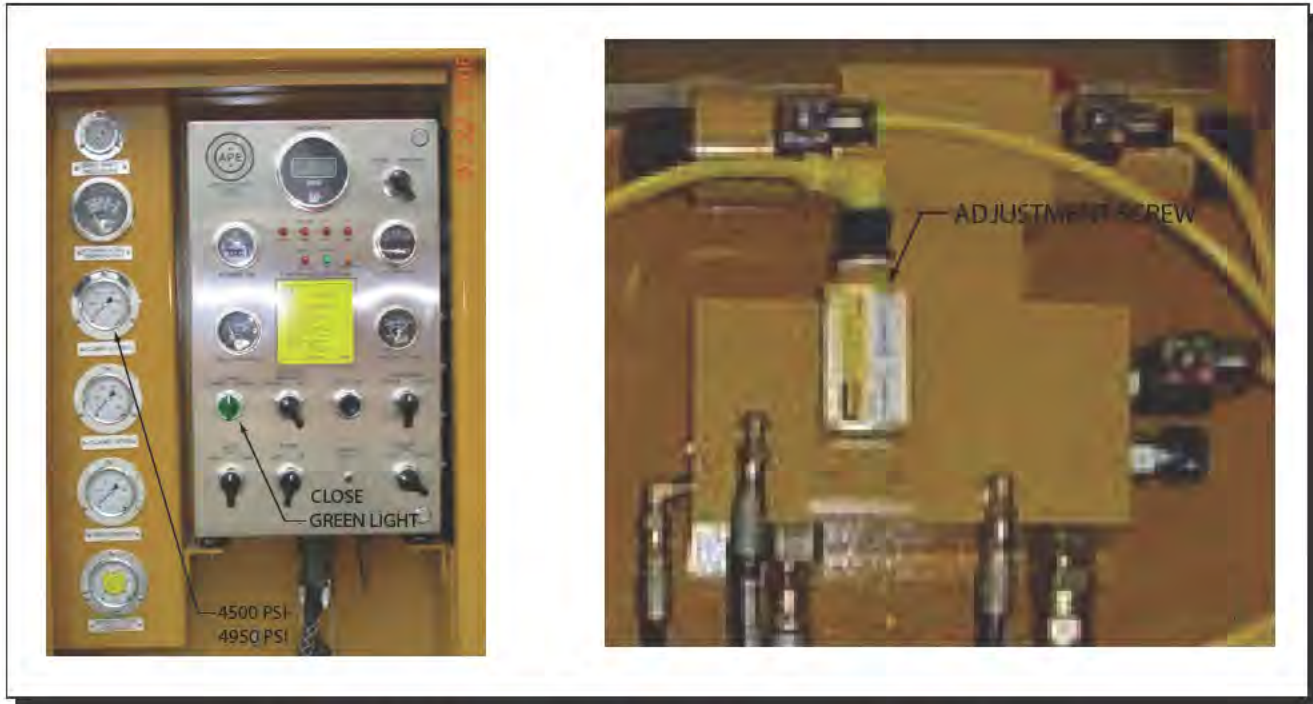

Figure 4-D. Checking Clamp Pressure Switch Setting

4. Adjust the clamp pressure switch setting. (If necessary). To set the pressure switch, turn the adjustment screw out using a screwdriver. (Turn it out a few turns counter-clockwise.) Turn clamp switch to "OPEN" for a second. Make sure the CLAMP OPEN GAUGE reads 4800 PSI. If it does not, then go back to the Step 2 and set the clamp relief valve first.

With clamp relief set at 4800 PSI, turn the clamp switch to "CLOSE". Green light should be on and clamp pressure should be very low or not reading at all.

Turn Adjustment Screw in (CW) until the green light goes off. Then, turn adjustment screw out (CCW) until green light comes on. (About 1/4 to 1/2 turn.) The CLAMP CLOSE GAUGE should read 4000 to 4800 PSI.

To check, turn clamp switch to "OPEN". The green light should be on.

Repeat procedure if necessary.



OPERATION / MAINTENANCE MANUAL

MODEL 250VM VIBRATORY DRIVER WITH MODEL 700VM POWER UNIT

7032 SOUTH 196th - KENT, WA. 98032 - (253) 872-0141 / FAX (253) 872-8710

IV. PREPARATION AND OPERATION (Continued...)

IV-8. Shut-down Procedures.

The following procedures explain what to do with the power unit to correctly shut down the APE Model 250VM Vibratory Driver.

- 1.) Stop the vibrator. (Refer to the power unit operating manual .)
- 2.) Allow the diesel engine to run for five minutes at 1000 engine rpm.
- 3.) Reduce engine speed to low idle for about 60 seconds.
- 4.) Shut engine off by turning off the main power switch.

WARNING: Do not shut the power unit engine down while the vibrator is clamped onto a pile. The clamp check valve will slowly bleed off if there is any leakage in the hose lines or worn clamp seals in the cylinder that moves the jaw open or closed.

IV-9. Operation of the Control Pendant.

1. All functions of the vibro can be controlled by the control pendant. It is the choice of the crew as to where best to locate the control pendant. Some prefer that the crane operator control all functions. Others prefer to give it to one of the ground crew so it can be positioned close to the work at hand. A 50 foot (15.2 M) cord is provided as standard equipment. If this is not long enough, additional 50 foot (15.2 M) sections can be added. Should the control pendant become damaged, all functions can be manually operated.

See page 7-16 in this manual for more details on operation. See page 7-21 of this manual for wiring diagram and control pendant components.

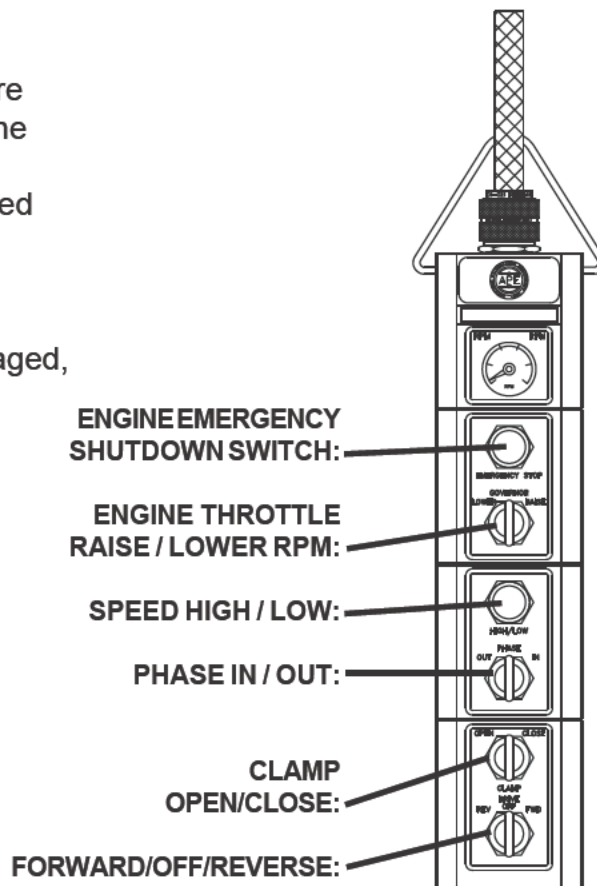

Figure 4-E. Control Pendant



OPERATION / MAINTENANCE MANUAL

MODEL 250VM VIBRATORY DRIVER WITH MODEL 700VM POWER UNIT

7032 SOUTH 196th - KENT, WA. 98032 - (253) 872-0141 / FAX (253) 872-8710

IV. PREPARATION AND OPERATION (Continued...)

IV-10. Normal steps to operate vibrator:

(Note: In order to operate power unit, Drive must be "OFF"). The Control Panel has a switch to control the Vibro in Manual mode or in Auto mode.

Manual Control

When the switch is in Manual, the control of the vibro's vibration (amplitude) is at the operator's control. The amount of amplitude can be set anywhere from minimum and maximum.

1. Position vibro on pile.
2. Set power unit speed to full throttle (factory set 1950 RPM).
3. Turn Clamp to "CLOSE" the switch will stay in the "CLOSE" position and wait for light to come on.
4. Turn Phase to "OUT" and hold for 2 seconds to ensure that vibro starts without vibrating.
5. Turn Drive to "FWD" to direct hydraulic oil to Vibro.
6. To drive piles, turn Phase to "IN" as desired, and lower crane line as vibro vibrates pile.
7. Push Speed HIGH / LOW button to "HIGH" if additional driving force/speed is desired.
8. To extract, pull up on vibro while vibrating.
9. See "Precautions and Rules for Operation" in this manual for more detailed operations on driving and extracting piles.
10. To stop the vibro turn Phase to "OUT" until all vibration ceases, then turn Drive to "OFF".
11. To release clamp, turn clamp switch to "OPEN" clamp light will turn off. Once the jaws are open release the switch.

Auto Control

When the switch is in Automatic, the control of the vibro's vibration (amplitude) is controlled automatically and only 0% or 100% amplitude are possible.

1. Position vibro on pile.
2. Set power unit speed to full throttle (factory set 1950 RPM).
3. Turn Clamp to "CLOSE" the switch will stay in the "CLOSE" position and wait for light to come on.
4. To start the vibro, turn Drive to "FWD" to direct hydraulic oil to Vibro. Timers in the control panel will phase the vibro into full eccentric moment automatically. Lower crane line as the pile vibrates.
5. Push Speed HIGH / LOW button to "HIGH" if additional driving force/speed is desired.
6. To extract, pull up on vibro while vibrating.
7. See "Precautions and Rules for Operation" in this manual for more detailed operations on driving and extracting piles.
8. To stop the vibro turn Drive to "OFF". Timers in the control panel will phase the vibro out to no eccentric moment then stop the flow of hydraulic oil to the vibro automatically.
9. To release clamp, turn clamp switch to "OPEN" clamp light will turn off. Once the jaws are open release the switch.



V. MAINTENANCE

V-1. Daily Maintenance Required Prior to Operation.

- 1.) Visually inspect the entire vibro for loose nuts or bolts. Put a wrench on the clamp bolts and check them for tightness.
- 2.) Grease the Jaw Plunger on the clamp housing.
- 3.) Check the oil level in the vibrator. Hang vibro from crane and look at sight gauge. Make sure the oil is half way up gauge. If you cannot read it then you can't run the vibro. Remove the gauge and clean it by spraying a shot of starting fluid at it. **YOU MUST KNOW THE LEVEL!**

IF THE OIL LOOKS BLACK OR MILKY THEN DRAIN THE GEARCASE AND ADD NEW OIL.

If you cannot read it then do not assume the level is ok.



Sight Gauge

**Oil Level
Mobil SHC 629
or equivalent.
(do not use veg. oil)**

- 4.) If the oil is milky or black then change it. **Change the oil every 150 hours regardless.**
- 5.) Check the fluid level in the power unit hydraulic tank.
- 6.) Look at all the hoses. Check for cuts or other damage that might cause an oil leak.
- 7.) Check the rubbers in the suppressor housing. Look for cracks.
- 8) **Check the following items:**

Check water level in radiator	Check engine oil
Check battery level	Check hydraulic return filter indicator
Check fuel level	Check fan belts on engine
Check oil level in pump drive	Check entire unit for hydraulic leaks
Check hydraulic oil level	Check condition of jaws before operating

V-2. Checklist After Power Unit Engine Has Started

- 1.) Check all hydraulic hoses for leaks. Make sure they hang free with no kinks.
- 2.) Check inside the Power Unit. Look at all hoses and valves, check for leaks.
- 3.) Check return filter gage at control panel with engine running at full rpm and hydraulic oil temperature above 80 degrees F. Replace filter when pressure is above 50 psi.
- 4.) Check wire rope sling and make sure it is in excellent condition.
- 5.) Check jaws for wear. Replace if necessary.
- 6.) Close jaws, make sure clamp light comes on.



OPERATION / MAINTENANCE MANUAL

MODEL 250VM VIBRATORY DRIVER WITH MODEL 700VM POWER UNIT

7032 SOUTH 196th - KENT, WA. 98032 - (253) 872-0141 / FAX (253) 872-8710

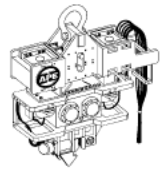

V. MAINTENANCE (Continued...)

V-3. Maintenance and Adjustments. (75 Hours)

Change the oil in vibrator gearbox. Remove the drain plug from bottom of gearbox and drain the oil into a bucket. Check oil for any metal shavings. Replace oil in gearbox by adding 9.5 gallons of standard weight oil. Mobil SHC 629.

Clean the gearbox breathers each time the oil is changed. Replace the breathers if necessary.

V-4. Maintenance and Adjustments. (Eccentric Bearings)

1.) Model 250VM - The Eccentric Bearings should be checked and/or replaced after every 2500 hours of operation.

V-5. Maintenance and Adjustments in Severe Conditions.

When average temperature is above (80 deg. F) or below (-1 deg. F) reduce servicing intervals to one half of those specified above.

When operating in the presence of dust or sand, reduce servicing intervals to one-third of those specified.

During stand-by or inactive periods, the servicing intervals may be reduced to one-half. The unit should be run every 30 days or less to keep internal parts lubricated.

V-6A. Lubrication - Vibratory Gearbox.

The Gearbox oil should be changed when black or milky. Mobil Gear SHC 629 or equal is the preferred oil. The gearbox requires 8.6 gallons of oil.

V-6B. Lubrication - Clamp Attachment.

The Clamp Attachment hydraulic oil must be checked and changed on a regular basis. The Clamp Cylinder Plunger should be checked for rust and debris. Lubricate the plunger on a regular basis using the grease zert on the side of the clamp housing .



OPERATION / MAINTENANCE MANUAL

MODEL 250VM VIBRATORY DRIVER WITH MODEL 700VM POWER UNIT

7032 SOUTH 196th - KENT, WA. 98032 - (253) 872-0141 / FAX (253) 872-8710



V. MAINTENANCE (Continued...)

V-7A. Power Unit - Filters, Fluid Types and Capacities.

FILTERS

LOCATION	QTY	ENGINE	FILTER TYPE	APE P/N
Engine Oil:	1	Caterpillar C-18	Caterpillar#1R-1808	555033
Engine Fuel:	1	Caterpillar C-18	Caterpillar#1R-0749	521026
Eng. Fuel Water Sep:	1	Caterpillar C-18	Caterpillar#1R-0771	555131
Air Filter Primary "Outer":	1	Caterpillar C-18	Caterpillar#6I-2509	521025B
Air Filter Secondary "Inner":	1	Caterpillar C-18	Caterpillar#6I-2510	521025A
Hyd. Oil Filter:	2		Zinga#ZLE-10	555009
Hand Pump Filter:	1		Zinga#AE-25	533011

Table 5-A. Power Unit Filters

ENGINE OIL TYPES AND CAPACITIES

LOCATION	ENGINE	OIL TYPE	CAPACITY
Hydraulic Oil-Main:	-----	Terresolve Envirollogic 146	475 gallons
Hyd Oil-Reserve:	-----	Terresolve Envirollogic 146	60 gallons
Engine Oil:	Caterpillar C-18	SAE 15W40 CH-4	34 quarts
Engine Water:		See note below	26 gallons
Fan Drive:	-----	Multi-Purpose Grease	
Pump Drive:	-----	90W or Syn. Mobil SHC 629	2 gallons
Fuel Tank :	-----	Diesel	165 gallons

Caterpillar Extended Life Anti-freeze p/n 119-5150 mix with water 50/50.

Caterpillar Extended Life Anti-freeze p/n 101-2844 premixed.

See page 5-7 for details on lubrication of the pump drive.



OPERATION / MAINTENANCE MANUAL

MODEL 250VM VIBRATORY DRIVER WITH MODEL 700VM POWER UNIT

7032 SOUTH 196th - KENT, WA. 98032 - (253) 872-0141 / FAX (253) 872-8710

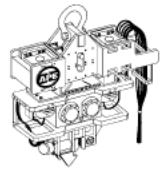

V. MAINTENANCE (Continued...)

V7-B. Power Unit - Hydraulic Fluid

When adding or changing hydraulic fluid APE uses only Terresolve Invirological 146 Hydraulic fluid which is non-toxic and will not harm soil or water and is biodegradable. Consult your local oil supplier for recommendations on mixing hydraulic oils. Change hydraulic oil if it looks milky. This includes all hydraulic lines leading to and from the vibro. Milky oil indicates that water is in the oil.

V7-C. Power Unit - Two Part Hydraulic Fluid Tank

The Hydraulic Tank is a two part tank. The main tank which the pumps feed from, cooled and filtered oil returns. The upper tank is an auxiliary tank to store extra or surplus hydraulic oil. Hydraulic oil may be transferred from the auxiliary tank to the main tank. There is a valve on the bottom of the hydraulic tank that should be opened into a bucket periodically before the engine is started. Water that may get into the system will settle to the bottom of the hydraulic tank, opening this valve will allow that water to be removed from the system.

V7-D. Power Unit - Draining and Filling Hydraulic Fluid Tank

1. Remove cap and open drain valve located on bottom of tank
2. Refill using hand pump and filter.
3. Prime both the clamp and the main pump before restarting.
4. Take extreme caution that no dirt or other unwanted particles enters the system.



OPERATION / MAINTENANCE MANUAL

MODEL 250VM VIBRATORY DRIVER WITH MODEL 700VM POWER UNIT

7032 SOUTH 196th - KENT, WA. 98032 - (253) 872-0141 / FAX (253) 872-8710

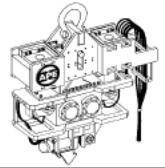

V. MAINTENANCE (Continued...)

V-7E. Power Unit - Changing Hydraulic Return Filter Element

The hydraulic return filters are mounted to a dual head adapter on the hydraulic tank inside the power unit. It is mounted high on the tank so that when the filter elements are removed the oil will not drain from the hydraulic tank. The filter has a gage at the control panel to tell you when it is dirty. When the hydraulic oil is above 80 degrees F and the return filter gauge reads 50 PSI it is time to change the filters.

V-7F. Power Unit - Steps to Remove the Element

1. Shut down power unit by turning off the diesel engine.
2. Place warning tag on control panel so that no one mistakenly starts the unit while filters are being changed.
3. Clean area around filters so that when they are removed there is no chance of introducing dirt into the hydraulic system.
4. Using a filter wrench, turn the filter counter clockwise and spin the filter off the filter housing.
5. Install new clean filter making sure the o-ring is in place.
6. Always change both filters at the same time.



OPERATION / MAINTENANCE MANUAL

MODEL 250VM VIBRATORY DRIVER WITH MODEL 700VM POWER UNIT

7032 SOUTH 196th - KENT, WA. 98032 - (253) 872-0141 / FAX (253) 872-8710





V. MAINTENANCE (Continued...)

V-8. Pump Drive

PUMP DRIVE LUBRICATION for APE Model 700VM Power Unit

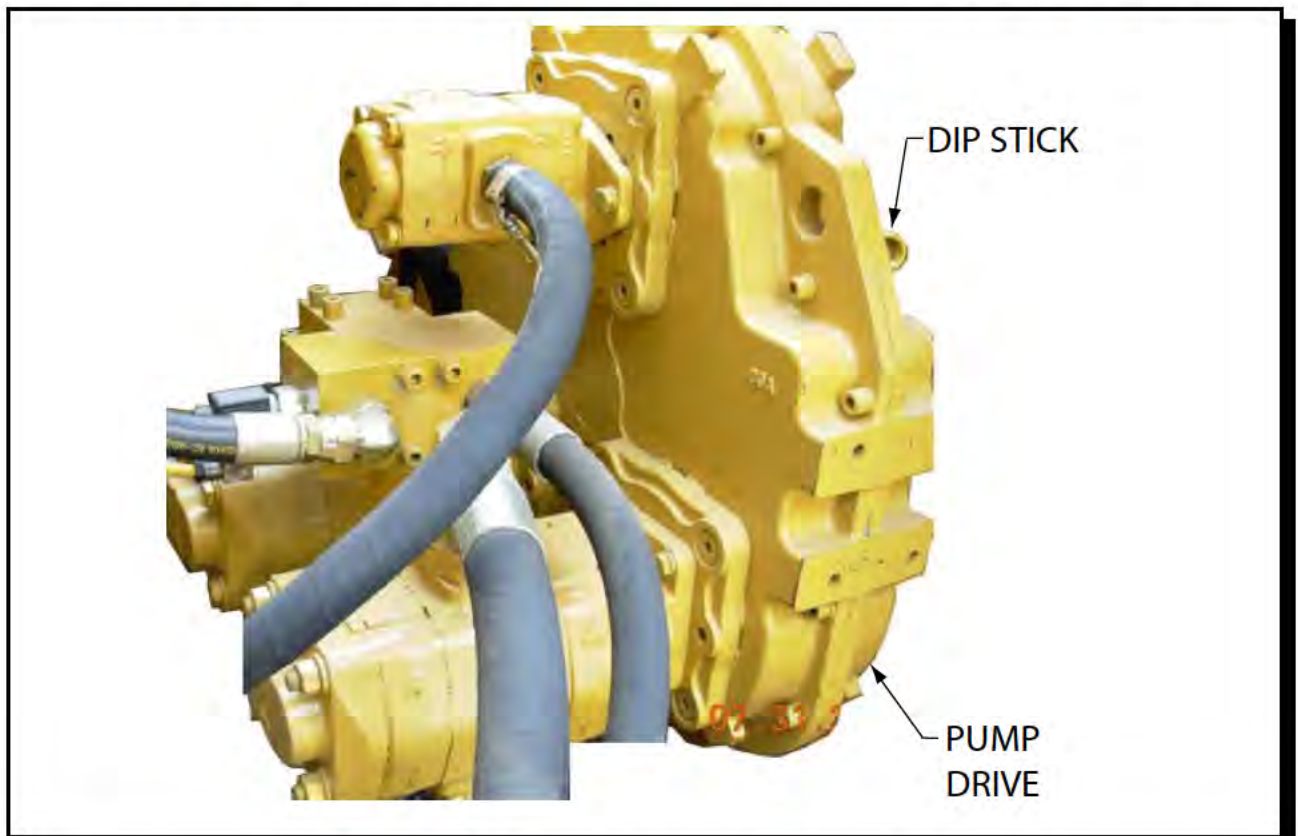

Figure 5-A. Pump Drive - Durst PD802F

The pump drive used on the APE 700VM power unit is a gear box that requires lubrication. The main gearbox takes about 2 gallons of oil. Check the level using the dip stick.

Oil changes are suggested every six months or 2000 hours, which ever occurs first.

Fill with Mobil SHC 629. Before operating the unit, check the oil level dip stick.



OPERATION / MAINTENANCE MANUAL

MODEL 250VM VIBRATORY DRIVER WITH MODEL 700VM POWER UNIT

7032 SOUTH 196th - KENT, WA. 98032 - (253) 872-0141 / FAX (253) 872-8710





OPERATION / MAINTENANCE MANUAL

MODEL 250VM VIBRATORY DRIVER WITH MODEL 700VM POWER UNIT

7032 SOUTH 196th - KENT, WA. 98032 - (253) 872-0141 / FAX (253) 872-8710

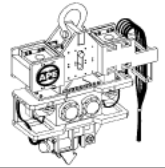

VI. VIBRO TROUBLE-SHOOTING

The following table lists some possible problems, causes and solutions. If a serious problem should occur, contact the factory for additional service information.

ITEM	PROBLEM	ITEM	PROBLEM
1.	Oil Blowing Out Between Gear box and Hydraulic Motor.	6.	Vibrator Won't Start When Start Button is Engaged.
2.	Vibro Gearbox is Too Hot.	7.	Clamp Won't Open When Clamp Open Switch is Engaged.
3.	Excess Oil in the Gearbox.	8.	Vibro Won't Come Up to Normal Operating Speed.
4.	Oil Blowing Out From Pop-Off Valve.	9.	Vibro Won't Stop When Stop Button is Engaged.
5.	Opening and Closing Clamp Jaws Seems Spongy or Slow.		

Table 6-A. Vibro Trouble-Shooting Index

Possible Cause	Remedy
<u>1. Oil Blowing Out Between Gearbox and Hydraulic Motor.</u>	
The breather may be plugged or damaged.	Remove the breather and clean it. If the breather is damaged replace it.
O-rings may not be sealing properly	Check the o-rings between the gearbox top plate and the motor. Clean the seal areas and replace the o-rings if needed.
<u>2. Vibro Gearbox is Too Hot.</u>	
Oil level may be too high.	Make sure the gearbox is level. Remove the oil over fill plug (located on the gearbox next to the sight gage). If oil flows out, the oil level is too high and must be lowered.
Oil may be too dirty.	Look at oil in the sight gage. If the oil is black or milky it must be replaced. If you are still not sure, remove the gear box drain plug and check the oil.
<u>3. Excess Oil in the Gearbox.</u>	
The seal between the gearbox and the hydraulic motor may be bad and is allowing oil to flow directly into the gearbox.	Remove the motor from the face of the gearbox. Check and clean the seal area, replace the seal if it looks bad.
<u>4. Oil Blowing out Pop-Off Valve.</u>	
Blocked flow in case drain line.	Check case drain line to see if it is pinched. Check case drain line for proper connection tightness.
Valve may be bad.	Remove and check the valve. Replace the valve if needed.
One or both motors may be damaged.	Remove the motors and have them checked for damage. Replace if needed.



OPERATION / MAINTENANCE MANUAL

MODEL 250VM VIBRATORY DRIVER WITH MODEL 700VM POWER UNIT

7032 SOUTH 196th - KENT, WA. 98032 - (253) 872-0141 / FAX (253) 872-8710

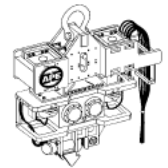

VI. VIBRO TROUBLE-SHOOTING (Continued...)

Possible Cause

Remedy

5. Opening and Closing Clamp Jaws Seems Spongy or Slow.

The plunger shaft may not be properly lubricated or may need cleaning.

Remove the movable jaw from the clamp. Inspect the plunger shaft and check for lubrication or debris build up. Clean the shaft if needed and then lubricate using the grease zert on the clamp body.

The clamp hoses may have air in them and may need bleeding.

Follow the procedures listed in this manual (page 4-3, Section IV-5.) for bleeding the clamp attachment hydraulic hoses.

6. Vibrator Won't Start When Start Button is Engaged.

Diesel engine is not running.

Start diesel engine.

Start relay contacts may not be closing.

Press and hold the Start Button on the pendant. If vibro starts, replace Start Relay.

Hoses may be connected improperly.

Check hoses and make connection corrections if required.

One or both hydraulic motors may not be operating properly.

Remove one hydraulic motor from the vibro. Leave the hoses connected. Run the power unit engine at approx. 1200 rpm. and press the start button. If motor runs, re-attach it to the vibro and perform the same test with the other motor. If one of the motors does not run, it must be replaced.

Vibro gearbox may be frozen up.

If motors are working fine and the drive pressure appears normal, then the vibro gearbox may be frozen and in need of repair.

Drive pressure is too low.

Manually close start valve at the drive manifold. If vibro will not start, replace the start valve. If vibro will not start, replace the drive pump.

7. Clamp Won't Open When Clamp Open Switch is Engaged.

Vibrator is running.

The clamp won't open while the vibro is in operation. To open the clamp, stop the vibro.

Diesel engine may not be running.

Start the power unit engine and allow clamp pressure to build.

There may be an electrical failure.

Check for the following:
- Defective clamp switch.
- Broken or loose wire in the pendant or pendant cable.
- Defective OPEN solenoid.
- Broken or loose wire between main power switch and START relay.
- Defective or sticking clamp timing delay relay.
- Broken or loose wire between main power switch and amphenol connector.

The clamp pump may be defective.

Check clamp pump for slipping belts and tighten if required. If clamp wont open, replace clamp check valves. If clamp still wont open, replace the clamp pump.



OPERATION / MAINTENANCE MANUAL

MODEL 250VM VIBRATORY DRIVER WITH MODEL 700VM POWER UNIT

7032 SOUTH 196th - KENT, WA. 98032 - (253) 872-0141 / FAX (253) 872-8710



VI. VIBRO TROUBLE-SHOOTING (Continued...)

Possible Cause

Remedy

8. Vibro Won't Come Up to Normal Operating Speed.

Defective hydraulic motor or drive pump.

If vibration frequency has been verified lower than normal, Replace the hydraulic motors one at a time to see if performance improves. If vibro still operates below normal speed, replace drive motor pump.

9. Vibro Won't Stop When Stop Button is Engaged.

There may be an electrical failure.

Check for the following:

- Defective STOP button.
- Broken or loose wire in the pendant or pendant cable.
- Defective START relay.
- Defective motor START valve.



OPERATION / MAINTENANCE MANUAL

MODEL 250VM VIBRATORY DRIVER WITH MODEL 700VM POWER UNIT

7032 SOUTH 196th - KENT, WA. 98032 - (253) 872-0141 / FAX (253) 872-8710

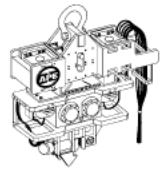

VII. MODEL 700VM POWER UNIT

VII-1. Hydraulic Circuitry.

VII-1A. Clamp Circuitry. (Used for extending and retracting jaw cylinder Item "F".)

Oil for the clamp circuit is provided by one half of a dual pump "G1". All oil to the inlet of this pump flows from the reservoir (Item "A") through a shut-off valve, which must be open at all times. Oil is then directed from the pump to the Clamp/Drill manifold "F" which contains the clamp directional control valve. When the clamp switch is in the neutral position, the oil flows through the clamp directional control valve and back to the oil tank. When clamp switch is moved to OPEN, solenoid "B" (on the clamp directional control valve) is energized the oil will flow out to the clamp cylinder and retract (open) the jaws. The clamp open pressure can be seen on the clamp pressure gage. When the clamp switch is moved to CLOSE, solenoid "A" (on the clamp directional control valve) will be energized and oil flow will be directed to the clamp cylinder. The clamp cylinder will then extend (close) the jaws. When clamp comes up to pressure 4800 psi, solenoid "A" will be de-energized, directing pump oil flow back to oil tank. Clamp pressure is maintained in clamp cylinder by a pilot operated check valve. At any time should the clamp pressure fall below 4500 psi. the clamp pressure switch will re-energize solenoid "A" and direct pump flow to the clamp cylinder. Maximum clamp pressure is limited by the clamp pressure relief valve set at 4800 psi. The quick disconnect couplers permit decoupling of clamp hoses.

VII-1B. Drive Circuit. (Used for operating APE vibrator, APE drill or any other unit, Item "B".)

There are two pumps (one dual pump "G2" and one half of "G3") that direct oil to the drive circuit (Vibro Motors). The maximum drive pressure is controlled by the drive pressure relief valve, to 5000 psi. max. When the drive switch is moved to the FWD position, solenoid "A" of the drive directional control valve is energized. Oil flow is directed to the vibro motors to rotate the eccentrics. When the drive switch is moved to the OFF position, oil flow is directed back to the tank through the drive directional control valve and solenoid "A" is de-energized.

The quick-disconnect couplings permit de-coupling of the drive and case drain hoses.

VII-1C. Phase In/ Out Circuit. (Used for phasing the eccentrics, to provide or eliminate vibration, Item "E".) Oil for the phase in/out circuit is provided by one half of the dual pump "G1" When the phase in/out switch is in the neutral position, the oil flows through the phase in/out directional control valve and back to the oil tank. When phase in/out switch is held "IN", the solenoid is energized, and oil will flow to the manifold (Item "D" located on the vibro) and synchronize the vibro eccentrics, creating increased mechanical vibration. Alternatively, when the phase in/out switch is held "OUT", the opposite solenoid is energized, and oil will flow to manifold "D", reversing synchronization, which will reduce mechanical vibration.

VII-1D. Vibro High / Low Circuit. (Used for increasing or decreasing vibration speed/force, Item "C".)



VII-1E. Hydraulic Schematic.

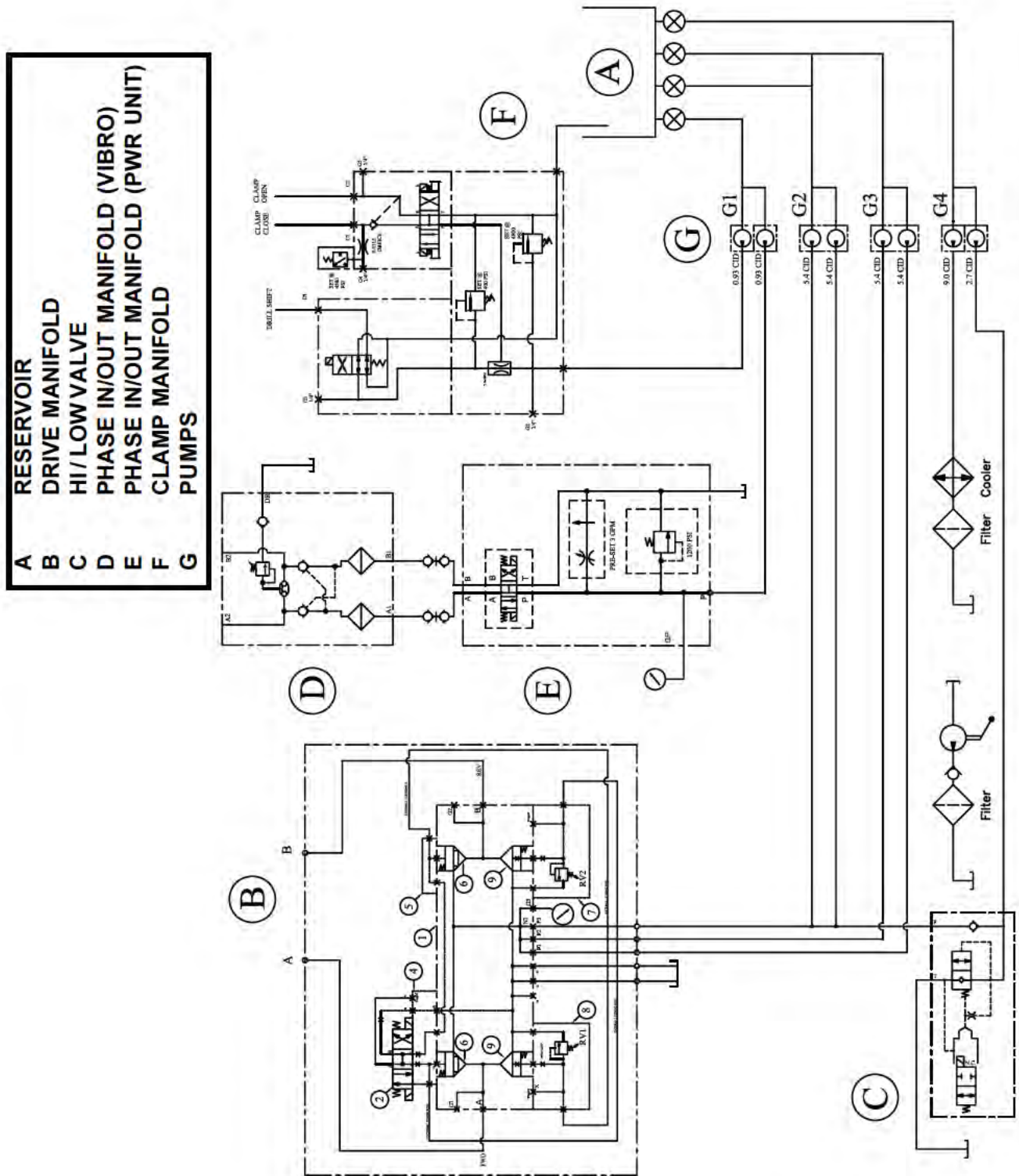

Figure 7-A. Hydraulic System Schematic



VII. MODEL 700VM POWER UNIT (Continued...)

VII-1F. Hydraulic Components - Clamp Drill Manifold 523003B

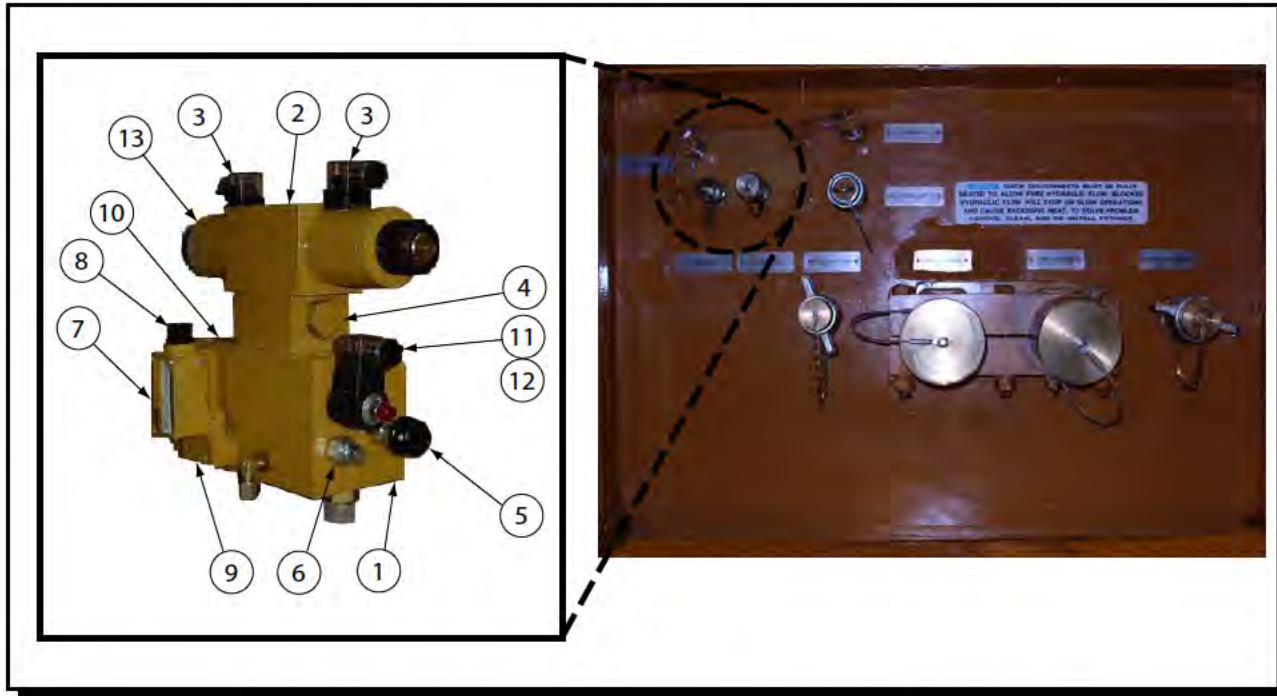
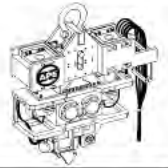

Figure 7-B. Hydraulic Installation - Clamp Drill Manifold

<u>ITEM</u>	<u>APE PART NO.</u>
1. MANIFOLD MACHINED	555073
2. CONTROL VALVE	555075
3. LIGHTED CONNECTOR	555077
4. PO CHECK VALVE	555079
5. CLAMP RELIEF VALVE	555081
6. DRILL RELIEF VALVE	555083
7. PRESSURE SWITCH	555085
8. STR SO COR CONNECTOR	555087
9. 90 DEG. TURN BLOCK	555089
10. PRIORITY FLOW CONTROL	555091
11. DRILL SOLENOID VALVE	555093
12. DRILL COIL	555095
13. CONTROL VALVE COIL	543049

Table 7-A. Model 350VM Clamp Drill Manifold 523003B



VII. MODEL 700VM POWER UNIT (Continued...)

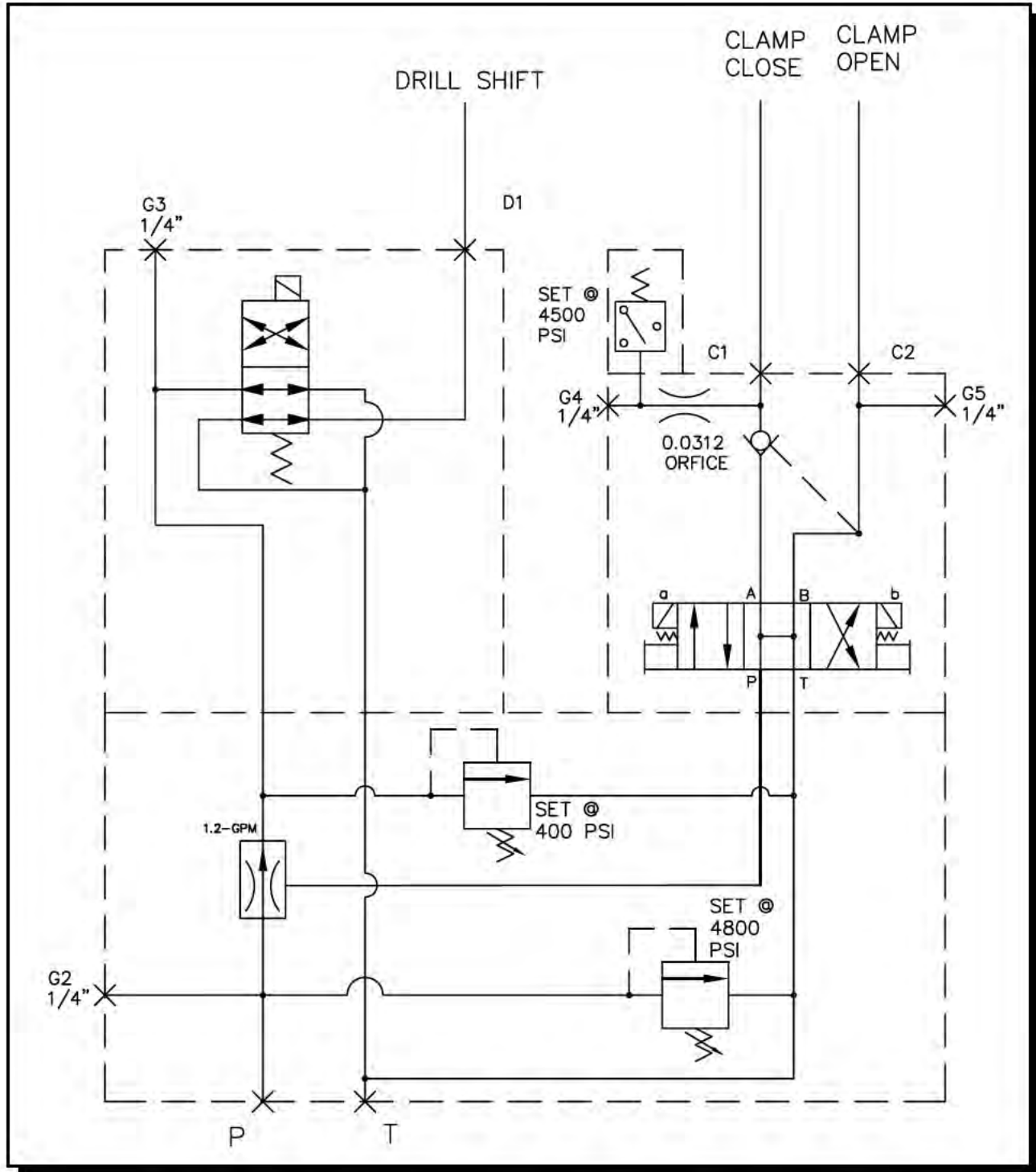

Figure 7-C. Hydraulic Components/Schematic - Clamp Drill Manifold



VII. MODEL 700VM POWER UNIT (Continued...)

VII-1G. Hydraulic Components - Drive Manifold Assy. 555183

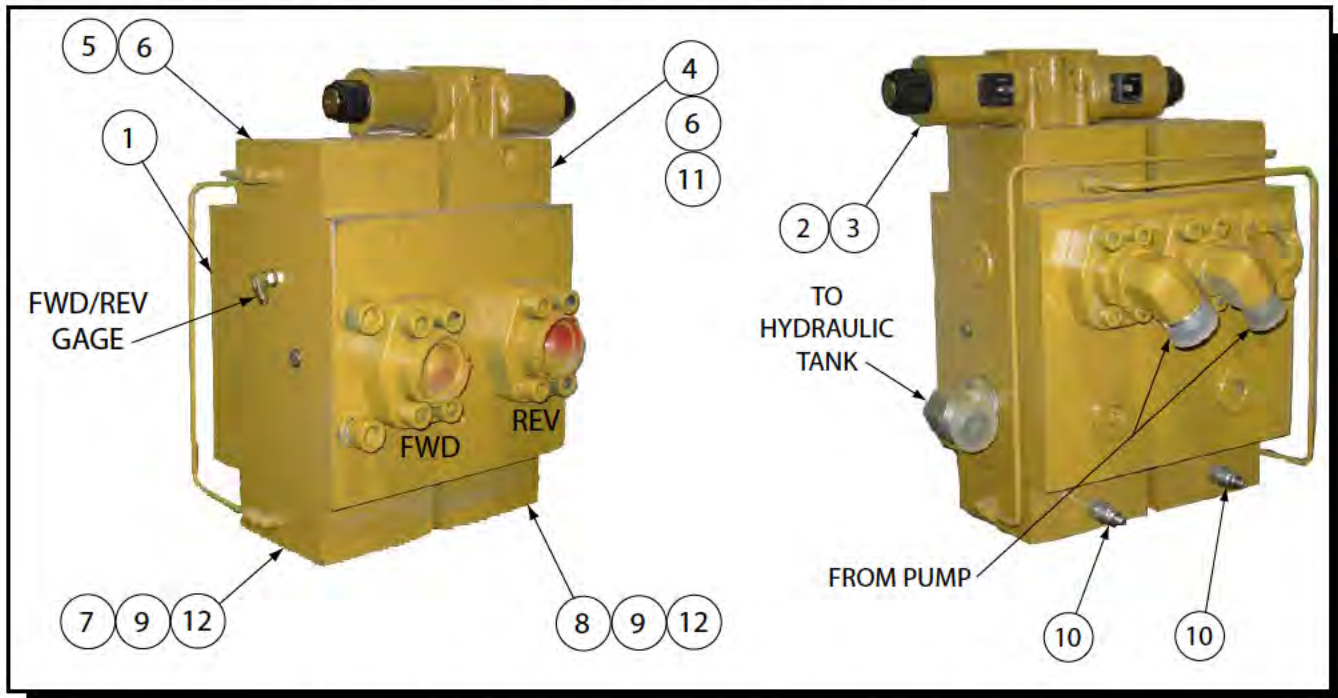
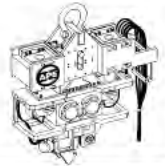

Figure 7-D. Hydraulic Installation - Drive Manifold

<u>ITEM</u>	<u>APE PART NO.</u>
1. MANIFOLD MACHINED	555185
2. SOLENOID CONTROL VALVE	555075
3. SOLENOID COIL	543049
4. CA1 CART COVER	555187
5. CA2 CART COVER	555189
6. CARTRIDGE CA1 & CA2	555203
7. CB2 CART COVER	555193
8. CB1 CART COVER	555191
9. CARTRIDGE CB1 & CB2	555201
10. RELIEF VALVE	555195
11. ORIFICE	555197
12. ORIFICE	555199

Table 7-B. Model 350VM Drive Manifold 555183



VII. MODEL 700VM POWER UNIT (Continued...)

VII-1G. Hydraulic Components - Drive Manifold 555183

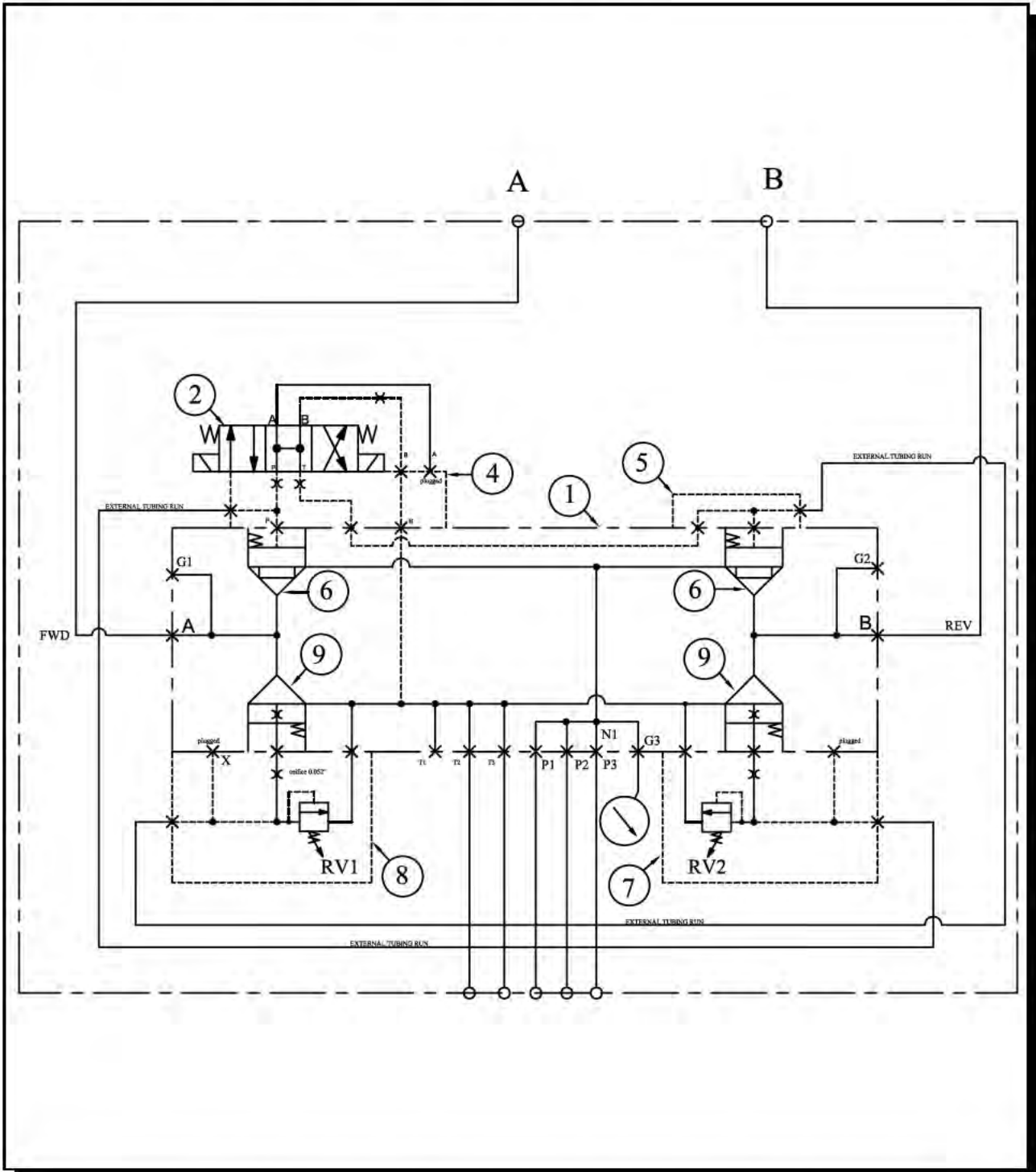

Figure 7-E. Hydraulic Components/Schematic - Drive Manifold



VII. MODEL 700VM POWER UNIT (Continued...)

VII-1H. Hydraulic Components - Phase In / Phase Out Manifold 555013

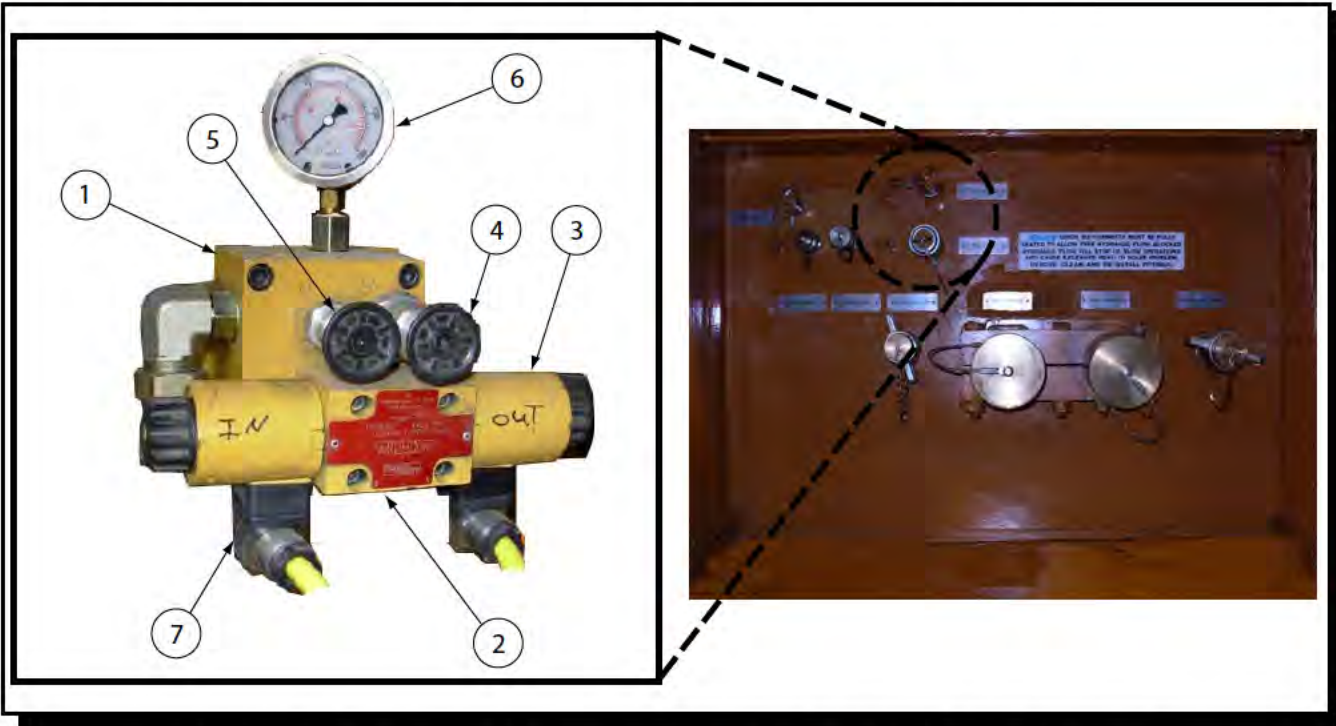

Figure 7-F. Hydraulic Installation - Phase In/Phase Out Manifold

<u>ITEM</u>	<u>APE PART NO.</u>
1. MANIFOLD MACHINED	555097
2. DIRECTIONAL VALVE	555099
3. COIL	555101
4. FLOW CONTROL	555103
5. RELIEF VALVE	555105
6. GAGE	555171
7. LIGHTED CONNECTOR	555077

Table 7-C. Phase In/Phase Out Mannifold 555013



VII. MODEL 700VM POWER UNIT (Continued...)

VII-1H. Hydraulic Components (Continued...)

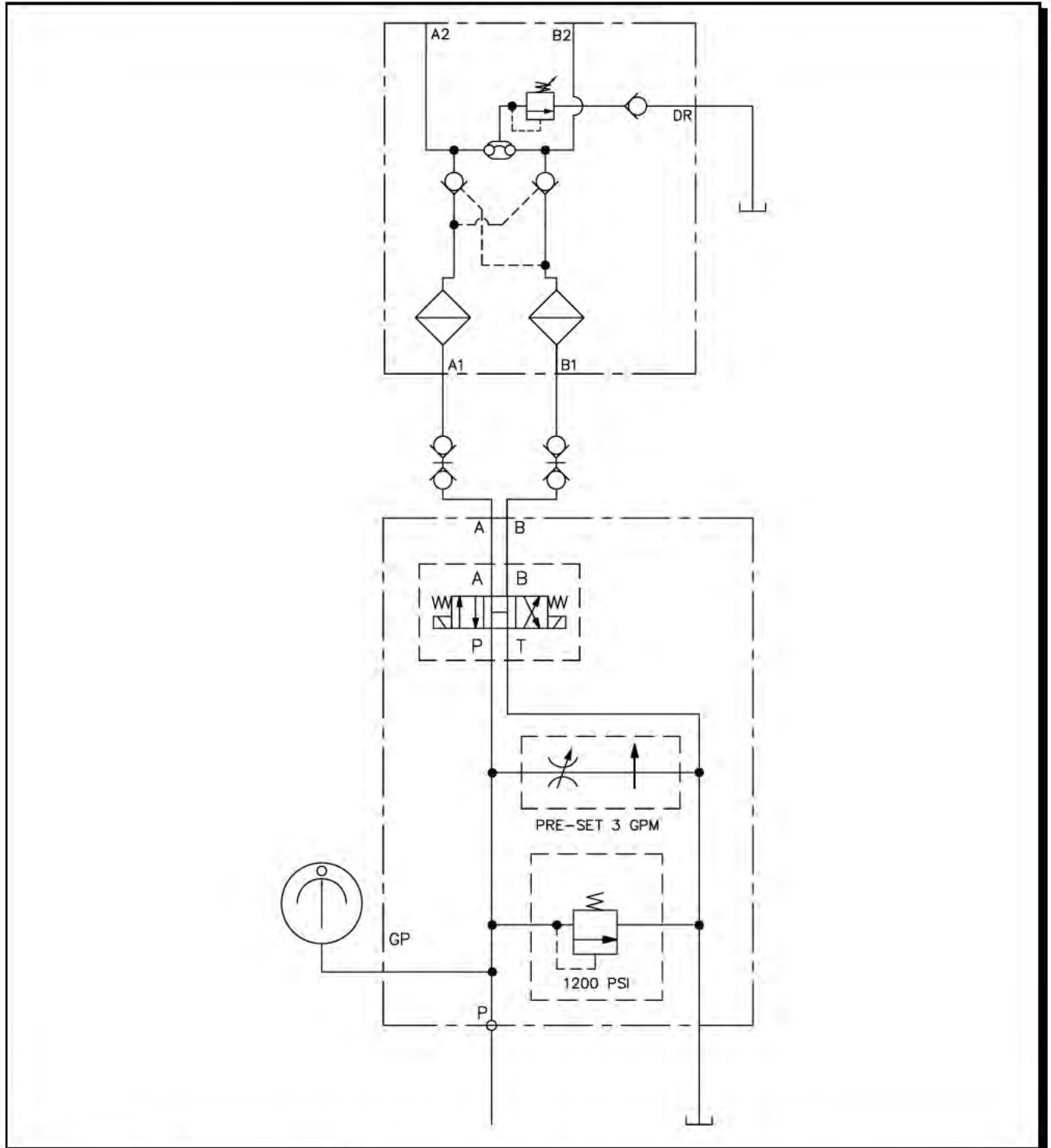

Figure 7-G. Phase In/Phase Out Hydraulic Schematic



OPERATION / MAINTENANCE MANUAL

MODEL 250VM VIBRATORY DRIVER WITH MODEL 700VM POWER UNIT

7032 SOUTH 196th - KENT, WA. 98032 - (253) 872-0141 / FAX (253) 872-8710



VII. MODEL 700VM POWER UNIT (Continued...)



OPERATION / MAINTENANCE MANUAL

MODEL 250VM VIBRATORY DRIVER WITH MODEL 700VM POWER UNIT

7032 SOUTH 196th - KENT, WA. 98032 - (253) 872-0141 / FAX (253) 872-8710



VII. MODEL 700VM POWER UNIT (Continued...)

VII-1I. Hydraulic Components Hose Identification and Routing

<u>QTY</u>	<u>DESCRIPTION</u>	<u>PARKER HOSE</u>
1	Vibro Case Drain	F471TC0606-12-12-12-29"
1	Clamp Open Gauge	F3010606-4-4-4-131 1/2"
1	Clamp Close Gauge	F3010606-4-4-4-123 1/2"
1	Clamp Manifold Return	F451TC0606-12-12-12-71"
1	Variable Moment Manifold (Return)	F471TC0606-12-12-12-98"
1	Drive Manifold (Drain)	F451TC0606-12-12-12-212"
1	Drive Manifold (Return)	F3010606-24-24-24-27 1/2"
1	Clamp Pump (Press. to Clamp Manifold)	F772TC0606-8-8-8-88 1/2"
1	Clamp Pump (Suction)	F8110606-20-20-20-95"
1	VM Pump (Pressure to VM Manifold)	F471TC0606-8-8-8-38 1/2"
1	Fuel (Tank to Filter)	F451TC0606-8-8-8-36 1/2"
1	Fuel (Return)	F451TC0606-8-8-8-79"
1	Hand Pump (Suction)	F8110606-20-20-20-117 1/2"
1	Hand Pump (Pressure)	F451TC0606-16-16-16-41"
1	Drive Forward & Reverse Gauge	F3010606-4-4-4-137 1/2"
1	Return Filter (Gauge)	F3010606-4-4-4-235"
1	Recirculation Pump (Press. to Cooler)	F3010606-20-20-20-110"
1	Recirculation Pump (Check. to Filter)	F3010606-20-20-20-36"
1	Cooler to Filter	F3010606-20-20-20-153"
1	Engine Oil Pressure Gauge	9190606-4-4-4-100"
1	Drill Shift	F3010606-4-4-4-110 1/2"
2	Drive Pump Pressure	F782TC0606-20-20-20-85"
1	Hi/Low Pump Pressure	F78T0606-16-16-16-41"
1	Hi/Low Pump Return	F3010606-16-16-16-36 1/2"
1	Pase Case Drain	F471TC0606-12-12-12-63 1/2"
1	Phase In Q.D.	F471TC0606-8-8-8-36"
1	Phase Out Q.D.	F471TC0606-8-8-8-38"

Table 7-D. Hose Identification and Routing (including fuel hoses)



VII. MODEL 700VM POWER UNIT (Continued...)

VII-1J. Hydraulic Components - Hydraulic Tank Connections

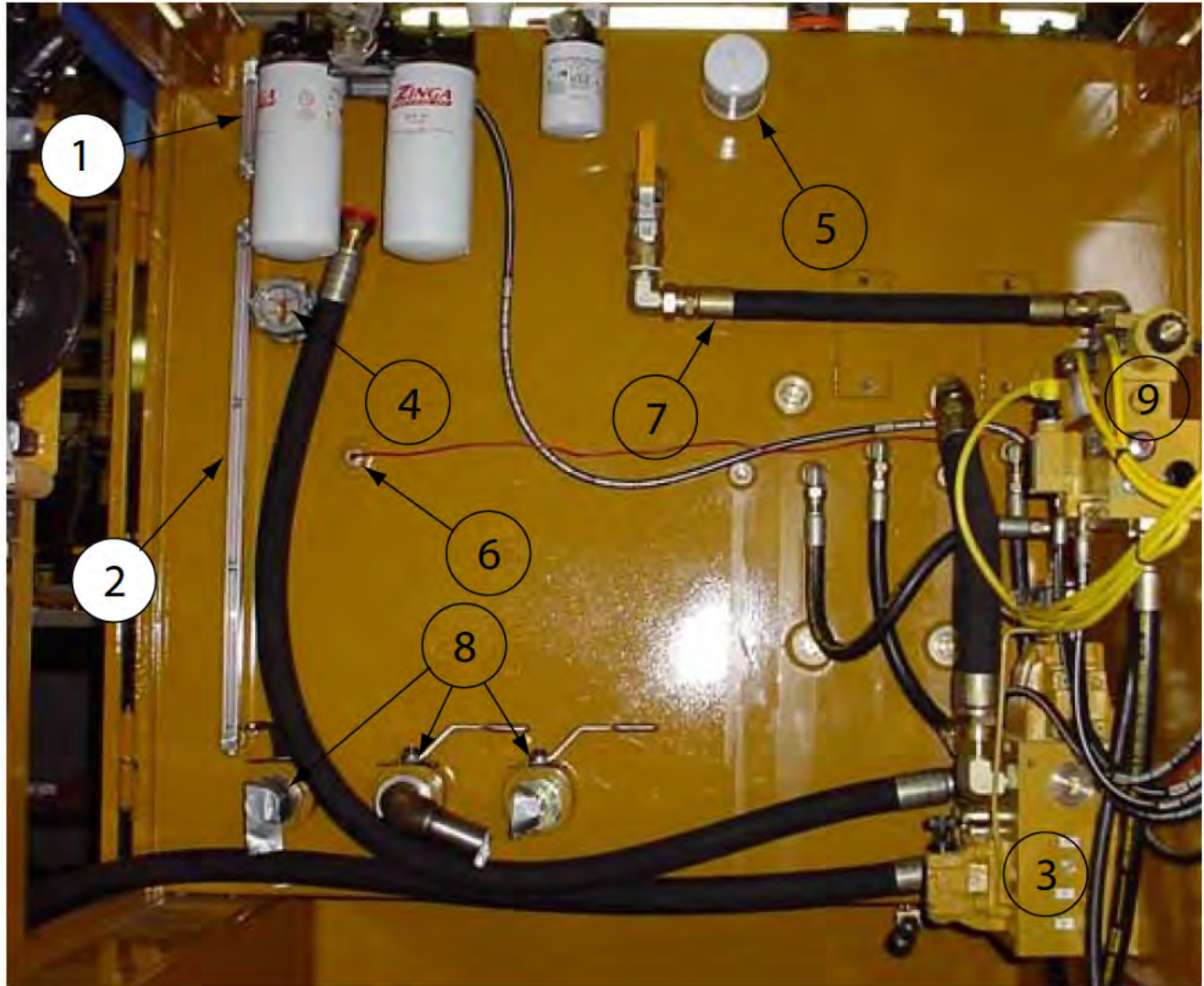

Figure 7-H. Hydraulic Component Identification - Tank Detail



OPERATION / MAINTENANCE MANUAL

MODEL 250VM VIBRATORY DRIVER WITH MODEL 700VM POWER UNIT

7032 SOUTH 196th - KENT, WA. 98032 - (253) 872-0141 / FAX (253) 872-8710

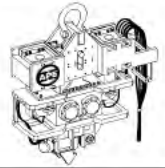

VII. MODEL 700VM POWER UNIT (Continued...)

VII-1J. Hydraulic Components - Hydraulic Tank Connections (Continued...)

<u>ITEM</u>	<u>DESCRIPTION</u>	<u>APE PART NO.</u>
1	6" SITE GAGE	513003
2	30" SITE GAGE	513005
3	DRIVE MANIFOLD ASSY.	555183
4	LEVEL SWITCH	513033
5	AIR BREATHER	555141
6	TEMP. SWITCH	523016
7	HYD. TANK TRANSFER ASSY.	
8	SUCTION VALVE (TO PUMPS)	555001
9	CLAMP/DRILL MANIFOLD	523003B

Table 7-E. Hydraulic Component Identification - Tank Detail



OPERATION / MAINTENANCE MANUAL

MODEL 250VM VIBRATORY DRIVER WITH MODEL 700VM POWER UNIT

7032 SOUTH 196th - KENT, WA. 98032 - (253) 872-0141 / FAX (253) 872-8710



VII. MODEL 700VM POWER UNIT (Continued...)

VII-1K. Return Filter.

Returning fluid is filtered by the return filter.

VII-1L. Oil Cooler.

The oil cooler cools the hydraulic fluid is continuously pumped thru cooler while the engine is running. This cooler is protected by a check valve that will bypass oil back to hydraulic tank.

VII-1M. Manual Pump.

A manual pump is provided to fill the hydraulic reservoir. A check valve prevents loss of fluid from the reservoir back through the manual pump.

VII-1N. Hydraulic Oil Temperature.

A temperature gauge indicates hydraulic oil temperature. The sending unit is mounted on the main tank.



VII. MODEL 700VM POWER UNIT (Continued...)

VII-1 O. Hydraulic Components - Hydraulic Pumps

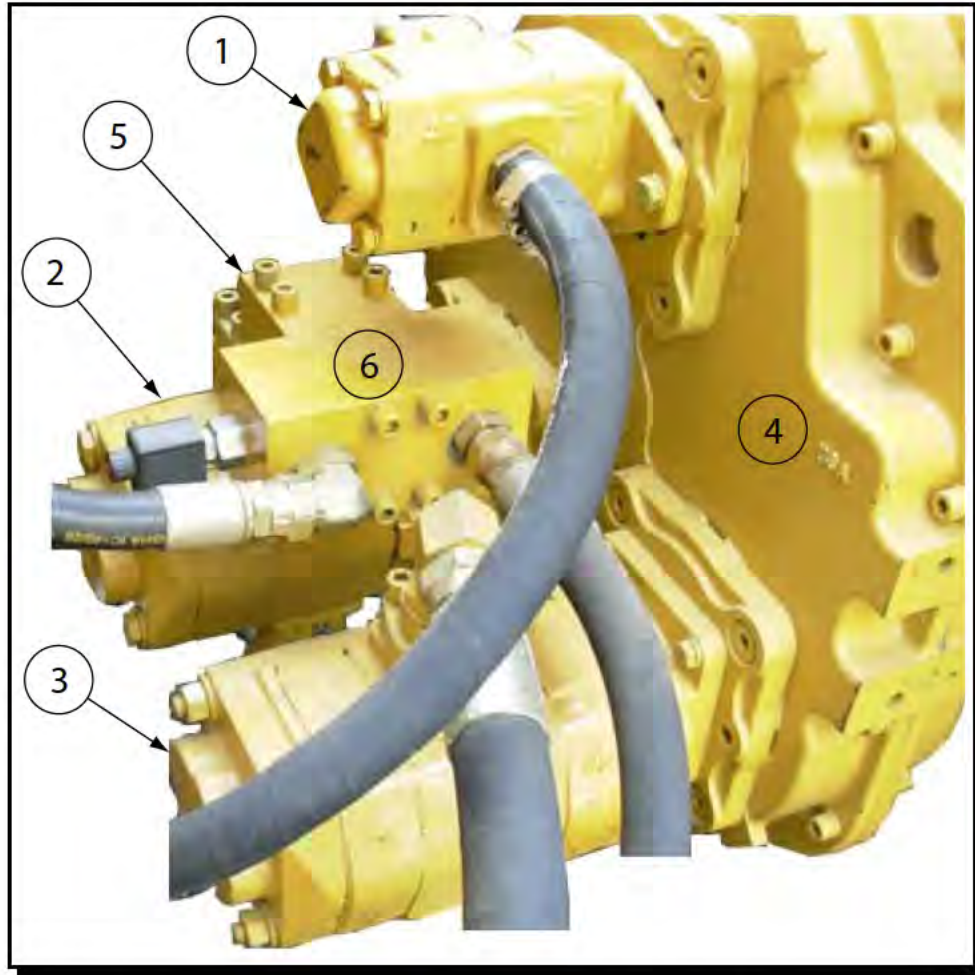

Figure 7-I. Hydraulic Pumps w/ Dump Valve

<u>ITEM</u>	<u>DESCRIPTION</u>	<u>PART NUMBER</u>	<u>FUNCTION</u>
1	Dual Pump (on eng)	555061	Clamp and Phase In / Phase Out
2	Drive Pump	555281	Vibro Hi-Low and Cooler
3	Drive Pump	523001	Vibro
4	Pump Drive	555019	Connect Engine to Pumps
5	90 Deg Turn Block	555055	Connect Pump to Dump Valve
6	Hi-Low Valve	555015	Revert flow back to tank

Table 7-F. Hydraulic Pumps



OPERATION / MAINTENANCE MANUAL

MODEL 250VM VIBRATORY DRIVER WITH MODEL 700VM POWER UNIT

7032 SOUTH 196th - KENT, WA. 98032 - (253) 872-0141 / FAX (253) 872-8710





OPERATION / MAINTENANCE MANUAL

MODEL 250VM VIBRATORY DRIVER WITH MODEL 700VM POWER UNIT

7032 SOUTH 196th - KENT, WA. 98032 - (253) 872-0141 / FAX (253) 872-8710

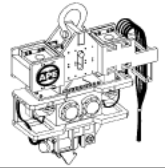

VII. MODEL 700VM POWER UNIT (Continued...)

VII-2. Electrical Controls: (Understanding How They Work)

The Main Control Panel (located behind one of the doors on the left side of the Power Unit) contains all of the equipment necessary to Start, Control, and Monitor the Engine, as well as control the Vibro functions. Remote control of the Vibro functions can be achieved by plugging either a Remote Pendant Switch, or a Radio Receiver into the 12 pin receptacle, located on the bottom of the panel. The Pendant Switch will allow the operator to move about in approx. a 50 ft radius of the Power Unit. The Radio will allow the operator to move about in approx. a 400 ft radius of the Power Unit.

VII-2A. Main Circuit Breaker

A circuit breaker is provided to protect the control wiring in the event of an electrical overload or a shorted circuit. If the circuit breaker should trip, find and repair the fault, then reset the breaker by pressing the circuit breaker reset button on the face of the Control Panel.

VII-2B. Tachometer

A digital tachometer, located on the front of the control panel, is provided to monitor the engine RPM. A magnetic sensor picks up a signal from the flywheel, and sends it to the tachometer. If there is reason to doubt the accuracy of the tachometer, check the engine RPM with a phototach, then calibrate the tachometer gage. The factory should be consulted for proper setting of the tach switches.

VII-2C. Hourmeters

Two hourmeters are on the Control Panel, one on the face of the panel, and one inside the panel. The hourmeter on the face of the panel monitors the time that the engine is running. The hourmeter inside the panel monitors the time that the "Forward Drive" is operating.

VII-2D. Engine Safety Shutdown Switch (Murphy Magnetic Switch)

Mounted to the back side of the Control Panel Door, is a Murphy Magnetic switch with a manual reset button protruding through the front of the Panel Door. When the contact on the switch is closed, power is supplied to the fuel valve solenoid, the hourmeter, and the "System OK" light. When the contact is open, the above items will be de-energized, and the engine will not run. The contact can be manually closed by pressing the "Reset" button on the face of the control panel. The contact will remain latched closed, unless the coil on the switch is energized. Each time the coil is energized, the contact will be unlatched, and the contact will open, to stop the engine. There are five switches that can energize the coil on the Murphy magnetic Switch, to stop the engine, (Engine Oil Pressure Gage, Engine Coolant Temperature Gage, Hydraulic Oil Temperature Gage, Hydraulic Oil Level Switch, and Emergency Stop Button on either the Pendant Switch, or the Radio).

VII-2E. Murphy "Engine Oil Press" gage

The Engine Oil Pressure Gage is located on the door of the Main Control Panel. A low cutoff switch is located inside the Murphy "Engine Oil Press" gage. When the engine oil pressure is too low, the switch will close to energize the coil in the Murphy Mag Switch. The cutoff pressure has been set at the factory. If the setting should need to be changed, use the adjustment screw provided in the front of the gage. A 1/16" allen wrench is required. Each time the engine is to be started, the Murphy Mag Switch coil will be energized by the switch in this gage. To start the engine, one must press and hold the manual reset button on the Murphy Mag Switch until sufficient engine oil pressure is achieved. Sufficient oil pressure has been achieved when the "Oil Press" light on the face of the Control Panel goes out.)



OPERATION / MAINTENANCE MANUAL

MODEL 250VM VIBRATORY DRIVER WITH MODEL 700VM POWER UNIT

7032 SOUTH 196th - KENT, WA. 98032 - (253) 872-0141 / FAX (253) 872-8710

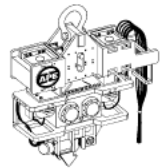

VII. MODEL 700VM POWER UNIT (Continued...)

VII-2F. Murphy “Engine Coolant Temp” gage

The Engine Coolant Temperature Gage is located on the door of the Main Control Panel. A high cutoff switch is located in the Murphy “Engine Coolant Temp” gage. When the engine temperature is too high, the switch will close to energize the coil in the Murphy Mag Switch. The cutoff temperature has been set at the factory. If the setting should need to be changed, use the adjustment screw provided in the front of the gage. A 1/16” allen wrench is required. (Do not set the cutoff temperature above 220 deg F. without factory permission)

VII-2G. Murphy “Hyd Oil Temp” gage

The Hydraulic Oil Temperature Gage is located in the Gage Assembly on the left of the Control Panel. A high cutoff switch is located in the Murphy “Hyd Oil Temp” gage. When the hydraulic oil temperature is too high, the switch will close to energize the coil in the Murphy Mag Switch. The cutoff temperature has been set at the factory. If the setting should need to be changed, use the adjustment screw provided in the front of the gage. A 1/16” allen wrench is required.

VII-2H. Hydraulic Oil Level Float Switch

The “Hyd Oil Level” float switch is located in the hydraulic oil reservoir, next to the sight gage. A glass window is provided in the switch so that the float and oil level can be observed. If the oil level gets too low, the switch will close to energize the coil in the Murphy Mag Switch.

VII-2I. “Emergency Stop” button

To stop the engine in an emergency, press the “Emergency Stop” button on the Remote Pendant Switch. This “Emergency Stop” switch will work, regardless of the position of the “Local-Pendant” selector Switch. There are two “Emergency Stop” switches on the power unit shell to also stop the engine in an emergency.

VII-2J. Pilot lights

There are five pilot lights on the face of the control panel that are associated with the Safety Shutdown Switch discussed above.

1. “System OK” light. A lit “System OK” light is an indication that the Engine Oil Pressure, Engine Coolant Temperature, Hydraulic Oil Temperature, and the Hydraulic Oil Level are all okay. When the “System OK” light is not lit, the engine will have been automatically stopped. The problem can be detected by observing the following lights.
2. “Engine Oil Press” light. Any time the engine oil pressure is too low, this light will be on, (with the following exception). If the “Engine Coolant Temperature Gage”, the Hydraulic Oil Temperature Gage, or the Hydraulic Oil Level Switch has stopped the engine, the “Engine Oil Press” light will not be on; but, one of the following lights will be on.
3. “Engine Coolant Temp” light. If the Engine Coolant Temp is too high, this light will be on.
4. “Hydraulic Oil Temp” light. If the Hydraulic Oil Temperature is too high, this light will be on.
5. “Hydraulic Oil Level” light. Any time the Hydraulic Oil Level is too low, this light will be on.

In addition to the above, there is a pilot light in each of the terminal connectors on the solenoid valves. By observing these lights, one can tell which solenoids are energized.



OPERATION / MAINTENANCE MANUAL

MODEL 250VM VIBRATORY DRIVER WITH MODEL 700VM POWER UNIT

7032 SOUTH 196th - KENT, WA. 98032 - (253) 872-0141 / FAX (253) 872-8710

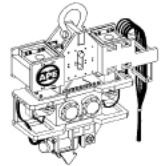

VII. MODEL 700VM POWER UNIT (Continued...)

VII-2K. Engine Control Switch “OFF-ON-START”

The Engine Control Switch is located on the front of the control panel, and is used to start and stop the diesel engine, as well as control power to all other electrical equipment on the power unit. This switch must be in the “on” position before the engine or any of the other electrical components will operate. The “off” and “on” positions are detented, but the “start” position is spring loaded to the “on” position. Turning the switch to the “start” position will energize the starter motor on the engine. The Local Remote switch must be in the local position for the engine control switch to be energized.

VII-2L. “LOCAL— PENDANT” Switch

This switch is also located on the main control panel, and determines the location from which the vibro can be operated. The vibro can not be operated from more than one location at a time. When this switch is turned to the “local” position, the vibro can be operated only by the switches on the power unit control panel. In the “pendant” position, operation of the vibro is controlled by either the Hand Held Pendant Switch, or the Radio (depending on which one is plugged into the bottom of the Control Panel).

CAUTION should be used when changing the position of this switch. Check to make sure that all of the Drive “Forward/Reverse” switches, and “Clamp” switches (including the Radio) are turned “off” before turning this switch. If any one of the above switches are “on”, the vibro eccentrics or clamp could be accidentally activated, causing mechanical damage or personal injury.

VII-2M. Governor Control Switches “RAISE-off-LOWER”

Governor Control switches can be found on the Main Control Panel, and the Held Pendant. The “Local-Pendant” switch determines which one is operable. To increase the engine rpm, turn the appropriate governor control switch to the “Raise” position. To decrease the engine rpm, turn the switch to the “Lower” position. On power units equipped with Caterpillar engines, the switches are connected directly to the engine governor. On power units equipped with Cummins engines, the switches control a Murphy Actuator, which in turn, operates a control arm on the engine governor. On both the Caterpillar and Cummins models, there is a manual throttle control, which can override the electric control. The electric control cannot lower the engine rpm below that set by the manual throttle control.

VII-2N. Clamp Control Switches (“OPEN-off-CLOSE”)

A Clamp Control Switch can be found on the Main Control Panel, the Hand Held Pendant, and/or the Radio Transmitter. The “Local-Pendant” switch determines which one is operable.

The Clamp Control Switches on the Control Panel and the Hand Held Pendant are detented in the “off” and “close” positions. The “open” position is spring loaded back to the “off” position.

When the ‘active’ Clamp Control Switch is in the “off” position, oil from the Clamp Pump is routed through the Clamp Solenoid Valve back to tank.



OPERATION / MAINTENANCE MANUAL

MODEL 250VM VIBRATORY DRIVER WITH MODEL 700VM POWER UNIT

7032 SOUTH 196th - KENT, WA. 98032 - (253) 872-0141 / FAX (253) 872-8710

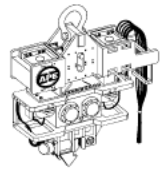

VII. MODEL 700VM POWER UNIT (Continued...)

VII-2N. Clamp Control Switches ("OPEN-off-CLOSE") (Continued...)

When the 'active' Clamp Control Switch is turned to the "open" position, The "open" solenoid on the Clamp Valve is energized, causing oil to be directed to the rod end of the Clamp Cylinder, provided the drive "Forward/Reverse" Switch is in the "off" position. (The clamp "open" solenoid cannot be energized when the "Drive Forward" switch is activated.) If the Clamp Control Switch is held in the "open" position after the clamp is fully open, oil pressure will build in the system until oil is flowing over a pressure relief valve, creating heat.

When the 'active' Clamp Control Switch is turned to the detented "Close" position, the "close" solenoid on the Clamp valve is energized, causing oil to be directed to the blind end of the Clamp Cylinder. Once the Clamp is closed, and sufficient oil pressure (4800psi) has built in the system, a pressure switch will open the circuit to the solenoid valve, and energize a pilot light located in the Clamp Control Switch Operator. A lit pilot light in the Clamp Control Switch Operator is an indication that there is enough oil pressure in the clamp circuit to safely run the vibro eccentrics.

If oil pressure in the Clamp circuit should bleed off to a predetermined level(4500psi), the pressure switch will de-energize the pilot light, and re-energize the "close" solenoid on the Clamp valve until pressure in the clamp circuit reaches 4800psi again. This cycle will continue until the Clamp switch is turned to the "off" position.

VII-2O. Drive Control Switches ("FORWARD/off/REVERSE")

Drive Control Switches can be found on the Main Control Panel and the Hand Held Pendant. The "Local-Pendant" Selector Switch determines which one is operable. The Drive Control Switches on the Control Panel and the Hand Held Pendant are detented in all three positions. They must be in the "off" position before the engine can be started.

Turning the switch to FORWARD will start the vibro eccentrics spinning. To stop vibro turn the switch to off. When operating the eccentrics on a vibro, only the "Forward" drive should be used. If the "Reverse" drive is used, the majority of the oil will pass through the anti-cavitation valves located in the vibro suppresser housing, and the vibro eccentrics will not run properly.

NEVER SWITCH FROM "FORWARD" TO "REVERSE" WHILE VIBRO IS OPERATING.

VII-2P. Phase Control Switches ("OUT/IN")

Phase Control Switches can be found on the Main Control Panel and the Hand-Held Pendant. The "Local-Pendant" Selector Switch determines which one is operable. The purpose of the phase In/Out feature is to provide infinitely variable control of vibration. The Phase Control Switches on the Control Panel and the Hand Held Pendant are detented in the neutral position.

Holding the Phase Control switch to "IN" allows the spinning counterweights to start to synchronize, thereby creating useful vibration. Only after the Drive Control Switch has been put in the FORWARD position should the vibro Phase Control Switch positioned to "IN". Holding the Phase Control switch to "OUT" de-synchronizes the counterweights, reducing vibration.



OPERATION / MAINTENANCE MANUAL

MODEL 250VM VIBRATORY DRIVER WITH MODEL 700VM POWER UNIT

7032 SOUTH 196th - KENT, WA. 98032 - (253) 872-0141 / FAX (253) 872-8710

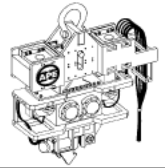

VII. MODEL 700VM POWER UNIT (Continued...)

VII-2Q. Phase Control Switches (AUTO / MANUAL)

Phase Control Switches AUTO / MANUAL can be found on the Main Control Panel. The purpose of the AUTO feature is to provide simplified operation control of vibration. The Auto / Manual Switches on the Control Panel is detented in either position.

Turning the Phase Control switch to "AUTO" uses the timers that are in the control panel. By this process when the FORWARD/off/REVERSE switch is turned to "FOR" the vibro spins to full speed out of phase and phases in automatically. To stop vibration turn the FORWARD/off/REVERSE switch to "off" the eccentrics will phase out automatically and stop spinning. The timers can be set to different times to allow the operator to determine amount of amplitude. The less phase in time equals less amplitude. Five seconds is enough time to deliver full amplitude.

VII-2R. Preparing the Electrical System for Engine Startup.

The following procedure should be followed at Engine Startup:

1. The Circuit Breaker must be closed (Pushed in and locked).
2. Turn the Clamp Switches on both the Control Panel and the Pendant to the 'Off' position.
3. Turn the Drive Switch on both the control panel and the Pendant to the 'Off' position.
4. Turn the Engine Control Switch to the 'On' position.
5. Check the Pilot Lights on the face of the Control Panel. If any of the lights, other than the "Engine Oil Pressure" light is on, correct the problem before proceeding. If the 'Engine Oil Pressure' light is on, proceed to step #8.
6. Depress and hold the button on the Engine Safety Shutdown Switch (Murphy Switch). This button must be depressed until Engine Oil Pressure is present.
7. Turn the Engine Control Switch to the 'Start' Position to engage the Starter Motor. Once the engine is running release the Engine Control switch. It will return to the RUN position.
8. Once Engine Oil Pressure is present, release the Engine Safety Shutdown Switch.



VII. MODEL 700VM POWER UNIT (Continued...)

VII-2S. Power Unit Electrical Schematic

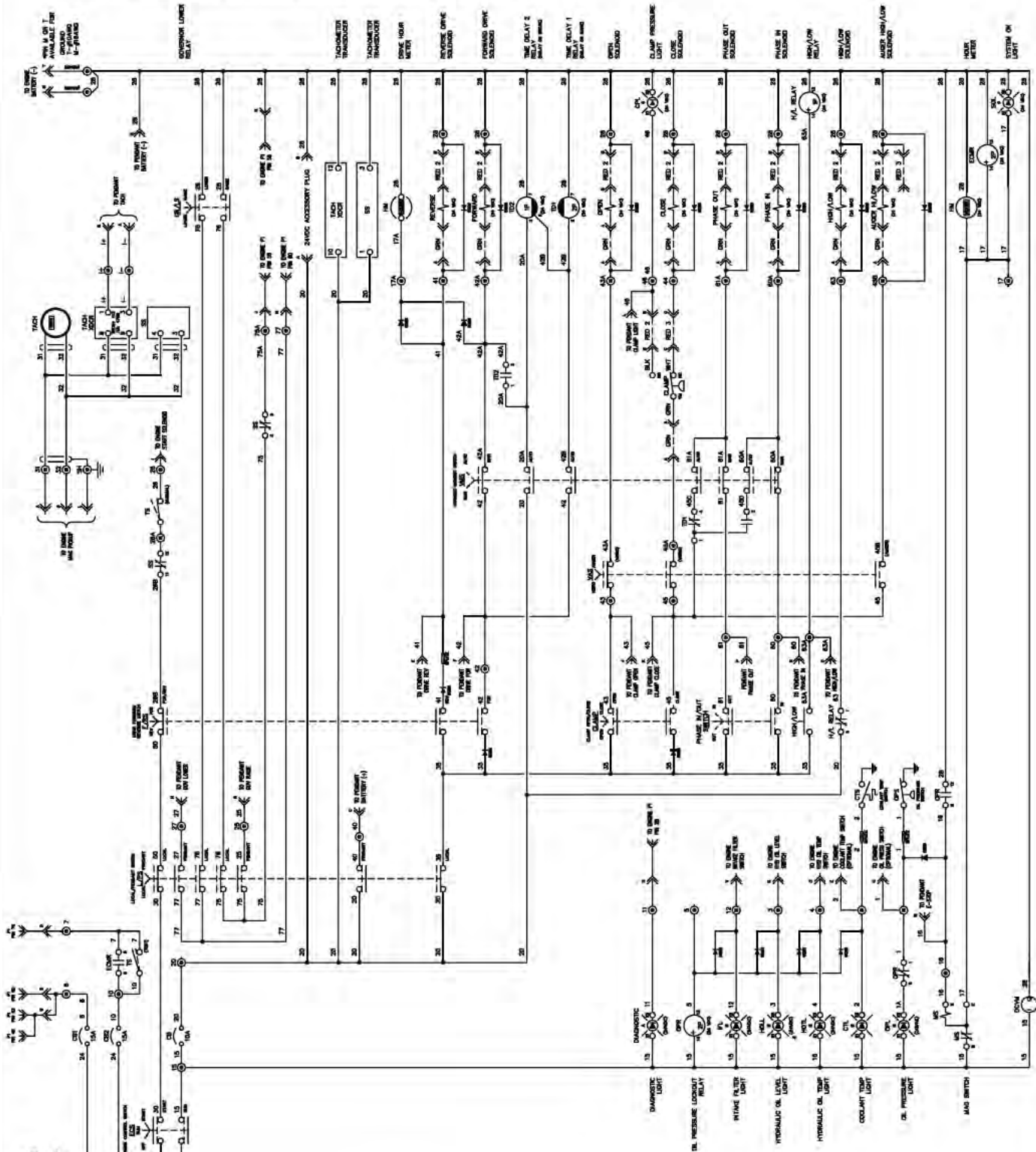



VII. MODEL 700 POWER UNIT (Continued...)

VII-2S. Electrical Schematic - Symbol Legend

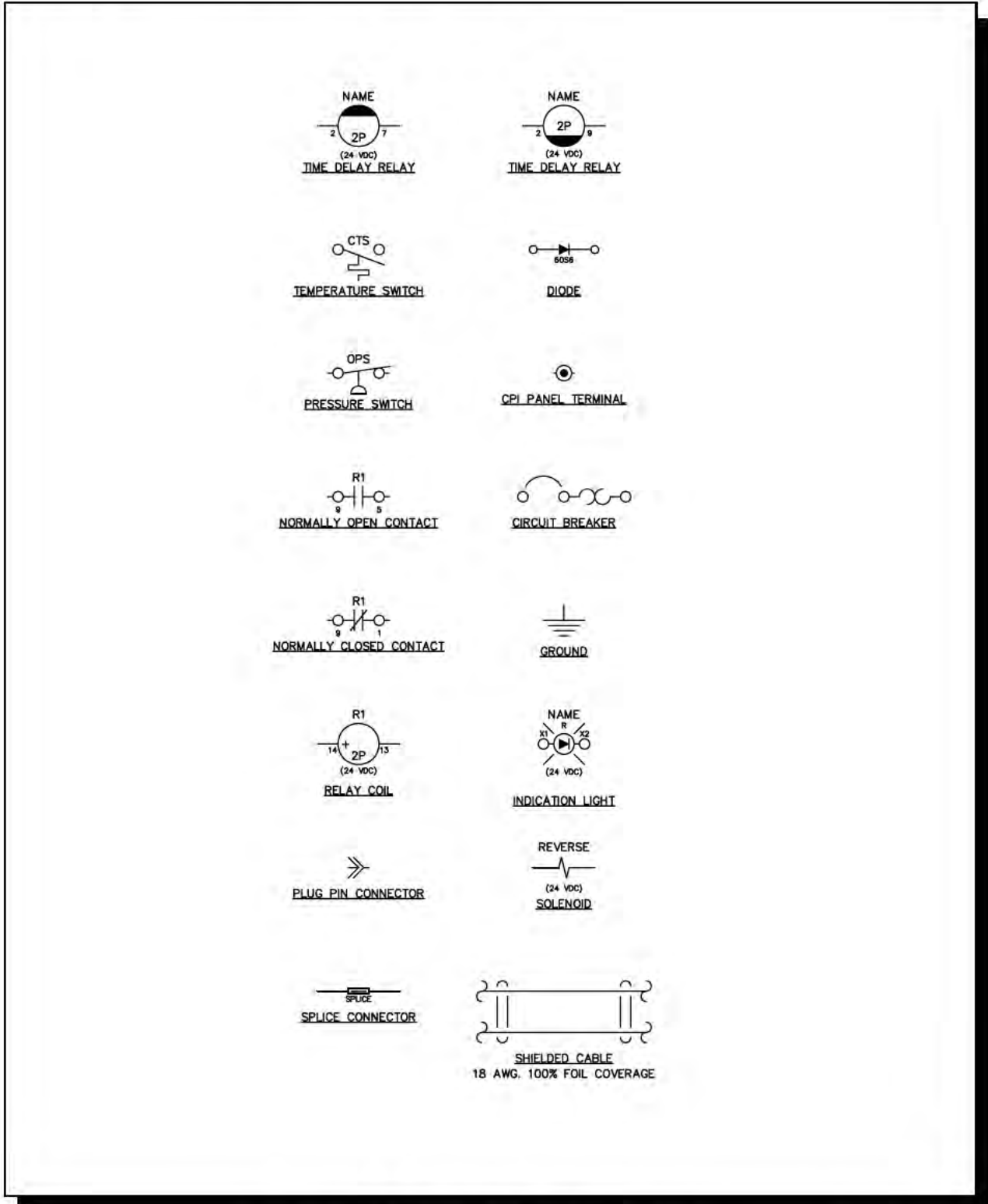

Figure 7-K. Electrical Symbol Legend



VII. MODEL 700 POWER UNIT (Continued...)

VII-3. Control Pendant

A "CONTROL PENDANT" is provided to allow operation of the power unit at a distance of up to 50 feet (15 meters) and can be extended using 50 foot extension cables. The "CONTROL PENDANT" is connected to the control panel via a multiconnector plug.

The Control Pendant is particularly handy as a trouble shooting tool, in that the operator can position himself near the Control Valves while checking them. To make the Control Pendant Switches operable, turn the 'Local-Pendant' Switch to the 'Pendant' position, and the Engine Control Switch to the 'On' Position. (The Engine does not need to be running.) Each time a solenoid is energized, a pilot light on the connector to that solenoid should light up.

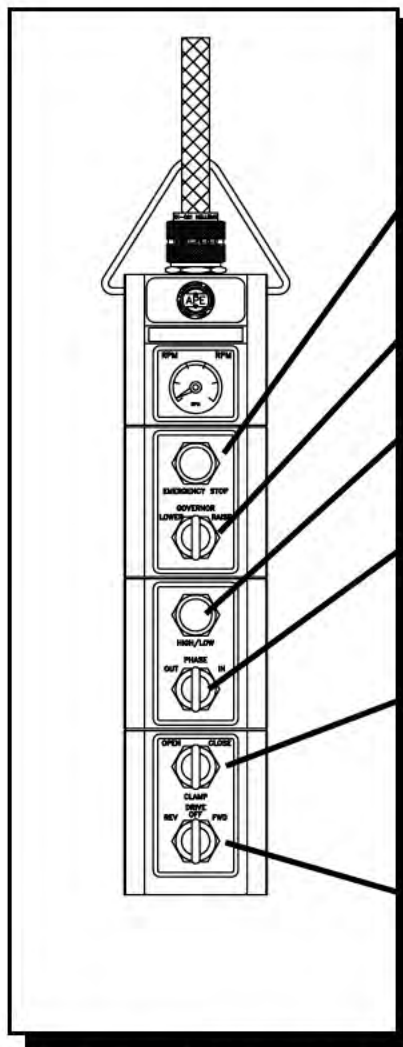

ENGINE EMERGENCY SHUTDOWN SWITCH

Press and hold to shut engine off. Do not use to shut engine off at the end of shift. Shut unit off at panel at end of shift. Button is for emergency only.

ENGINE THROTTLE "RAISE/LOWER" RPM

Three position switch. Turn and hold switch to raise or lower diesel engine rpm.

"HI / LOW" SWITCH

Push Button Switch. Activates solenoid on Hi / Low manifold. Increases / decreases hydraulic flow to Vibro.

PHASE IN/OUT SWITCH

3-position spring return (to neutral) switch. Turn and hold switch to IN or OUT as desired to increase or decrease vibration.

CLAMP OPEN/CLAMP CLOSE

Lighted switch. Turn to close to extend jaw and clamp vibro to pile. Light comes on when clamp is closed and locked. Turn to open to retract jaw and release vibro from pile. Switch must remain in closed position to hold clamp to pile. Sometimes the light will not come on. It could be burnt out or shorted. Check clamp pressure gauge and make sure it reads at least 3800 psi before vibrating any pile. Contact APE if light is not working.

FORWARD/OFF/REVERSE

Three position switch. Turn to forward to operate vibro. Turn to off to stop vibro. Turn to reverse when using power unit to run a drill motor. Vibro is not supposed to vibrate in reverse. If it does then switch the two yellow cables labeled "drive" and "reverse" located on the other side of the control panel.

Figure 7-L. Control Pendant

WARNING: Never leave vibro clamped to a pile without the crane line attached. The clamp cylinder could bleed off causing the vibro to drop. Never hoist a pile in the air without a safety line attached to the pile. Should the clamp close line become damaged and leak, the clamp cylinder could lose pressure and drop the pile.



VII. MODEL 700 POWER UNIT (Continued...)

VII-3A. Control Pendant Wiring Diagram

The following is the pin wiring configuration and the wire colors of the amphenol connectors for the remote control pendant cable.

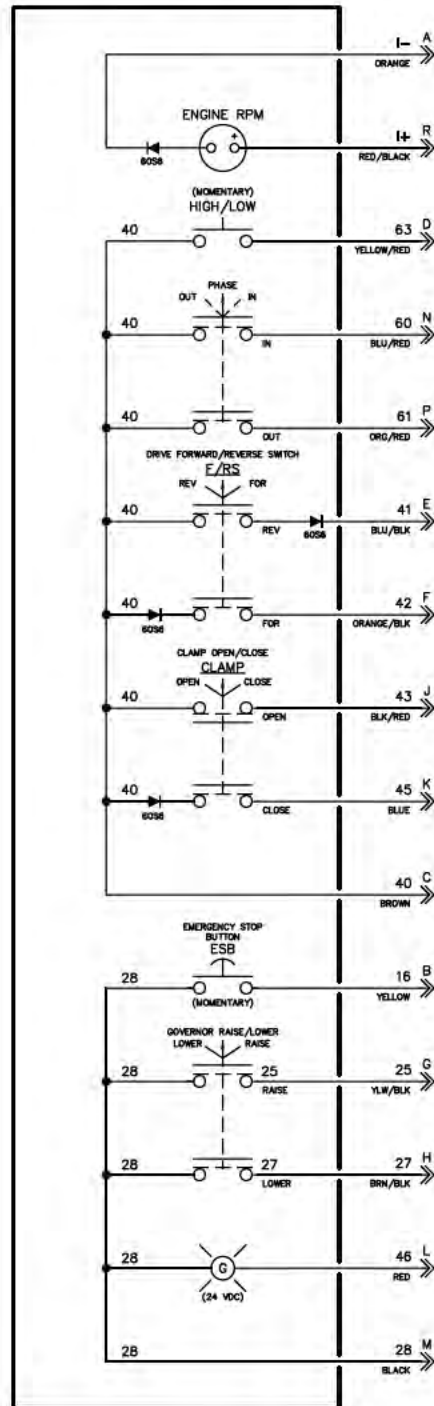

Figure 7-M. Control Pendant Wiring Diagram



OPERATION / MAINTENANCE MANUAL

MODEL 250VM VIBRATORY DRIVER WITH MODEL 700VM POWER UNIT

7032 SOUTH 196th - KENT, WA. 98032 - (253) 872-0141 / FAX (253) 872-8710



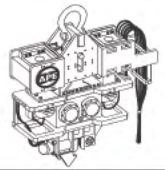

VIII. PHASE SHIFTER REMOVAL AND INSTALLATION

VIII-1. Overview

The following instructions are for removal and installation of the phase shifter. The phase shifter is a component on variable moment vibratory driver/extractors, which controls the geared eccentrics from zero amplitude to maximum amplitude by timing the upper and lower eccentrics in the gear box.

For help diagnosing whether your phase shifter is defective, or for further assistance, please consult our factory at (253)-872-0141.

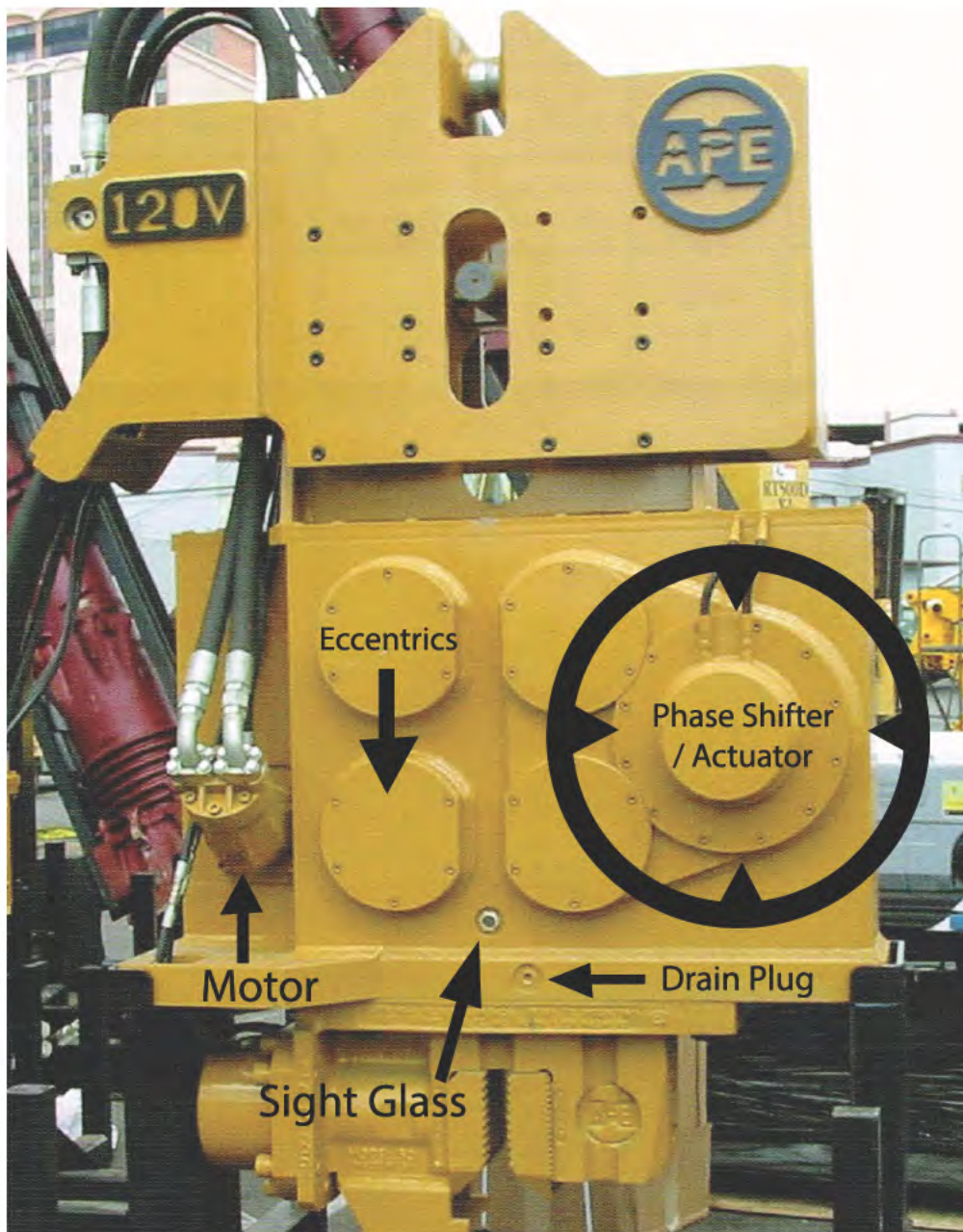

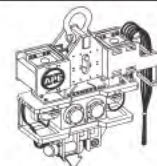

VIII. PHASE SHIFTER REMOVAL AND INSTALLATION

VIII-2. Replacement

1. After the phase shifter has been diagnosed as defective, verify that the hammer is fully phased in. ("Phased in" means both rows (all) of the eccentrics are in the down position, full amplitude.)
2. Drain the gear box oil. Remove inspection covers, front and rear, from the phase shifter housing.
3. Disconnect and plug the hydraulic hoses to the Deublin Swivels (A).
4. Remove both Deublin Retainer Plate (B) and slide both Dublin swivels out of the phase shifter. (This must be done with the vibro standing up.)
5. Remove actuator housing one short (C) and one long (D) from the phase shifter. Remove both seal retainer plates.

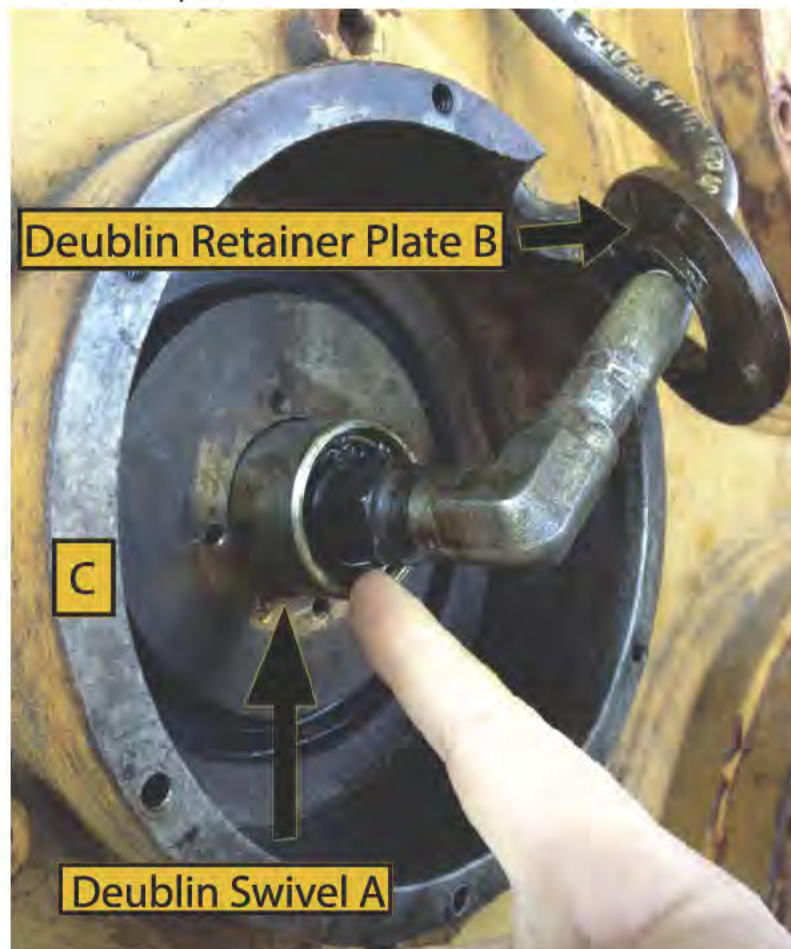
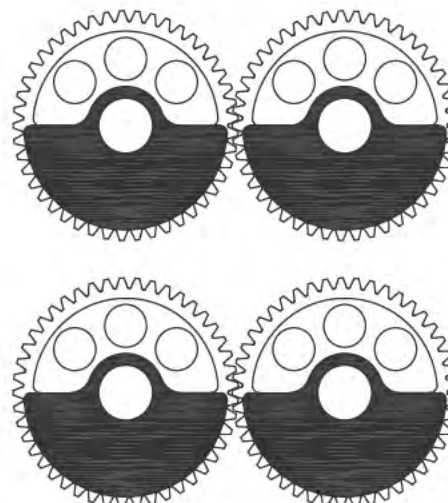

1. Lay the hammer over and block up on wood so that the hammer is level, with the hydraulic drive motor facing up. This insures the eccentrics will not rotate when you remove the phase shifter.
2. Remove bearing retainer ring (E) from the body of the hammer using the threaded jacking holes. (This will allow removal of the phase shifter from the gear box.)
3. Using an overhead crane or forklift, remove phase shifter from gear box by steadily pulling the phase shifter. (Slight wiggling back and forth movement may be necessary.)
4. You must verify that the new phase shifter is in the "phase in" position. This is accomplished by installing the dublin swivel and retainer plate into the motor side of the phase shifter and applying 750 MAX p.s.i. hydraulic pressure. This will insure that the phase shifter is correctly timed with the eccentrics.

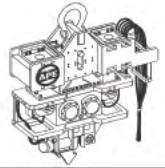

VIII. PHASE SHIFTER REMOVAL AND INSTALLATION

VIII-2. Replacement (Continued)



1. You are now ready to re-assemble. Repeat steps in reverse, in order from 9 to 1.
2. Be sure that the snap ring in the end of the deublin swivel is removed before the deublin retainer plate (B) is installed.
3. Replenish gear box oil through fill plug (Schaeffer 268) to appropriate level, according to the sight gauge.
4. Connect hydraulic hoses from vibro to power unit, bleed system from actuator hoses and test.

APE recommends new seal kits, o-rings and bolts for all APE replacement products. Consult factory for torque specs. Please clean all parts thoroughly. Use red lock-tight on bolts without lock washers. Use anti-seize on bolts with lock washers. Precautionary measures should be taken to make sure you have a clean working environment, and have all necessary clean-up supplies available, in the event of an oil leak.



OPERATION / MAINTENANCE MANUAL

MODEL 250VM VIBRATORY DRIVER WITH MODEL 700VM POWER UNIT

7032 SOUTH 196th - KENT, WA. 98032 - (253) 872-0141 / FAX (253) 872-8710

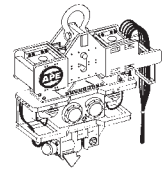

RECOMMENDED TIGHTENING TORQUE

Nominal Screw Size	Nominal Socket Size	Tightening Torque Ft-Lbs. (Kg-M)	Nominal Screw Size	Nominal Socket Size	Tightening Torque Ft-Lbs. (Kg-M)
#10-24	5/32	6 Ft-Lbs. (.83 Kg-M)	#10-32	5/32	6 Ft-Lbs. (.83 Kg-M)
1/4-20	3/16	13 Ft-Lbs. (1.8 Kg-M)	1/4-28	3/16	15 Ft-Lbs. (2.1 Kg-M)
5/16-18	1/4	27 Ft-Lbs. (3.7 Kg-M)	5/16-24	1/4	30 Ft-Lbs. (4.2 Kg-M)
3/8-16	5/16	48 Ft-Lbs. (6.6 Kg-M)	3/8-24	5/16	55 Ft-Lbs. (7.6 Kg-M)
7/16-14	3/8	77 Ft-Lbs. (10.6 Kg-M)	7/16-20	3/8	86 Ft-Lbs. (11.9 Kg-M)
1/2-13	3/8	119 Ft-Lbs. (16.4 Kg-M)	1/2-20	3/8	133 Ft-Lbs. (18.4 Kg-M)
5/8-11	1/2	234 Ft-Lbs. (32.3 Kg-M)	5/8-18	1/2	267 Ft-Lbs. (36.9 Kg-M)
3/4-10	5/8	417 Ft-Lbs. (57.6 Kg-M)	3/4-16	5/8	467 Ft-Lbs. (64.5 Kg-M)
7/8-9	3/4	676 Ft-Lbs. (93.4 Kg-M)	7/8-14	3/4	742 Ft-Lbs. (102.5 Kg-M)
1-8	3/4	1,009 Ft-Lbs. (139.4 Kg-M)	1-12	3/4	1,126 Ft-Lbs. (155.6 Kg-M)
1-1/4-7	7/8	1,600 Ft-Lbs. (221.1 Kg-M)	1-1/4-12	7/8	1,800 Ft-Lbs. (248.8 Kg-M)
1-1/2-6	1	2,800 Ft-Lbs. (387 Kg-M)	1-1/2-12	1	3,000 Ft-Lbs. (414.6 Kg-M)

NOTE: These values are for Socket head cap screws only. Button heads, Flat heads and Set screws have different values. Check the Allen Hand Book for correct torque specifications.