

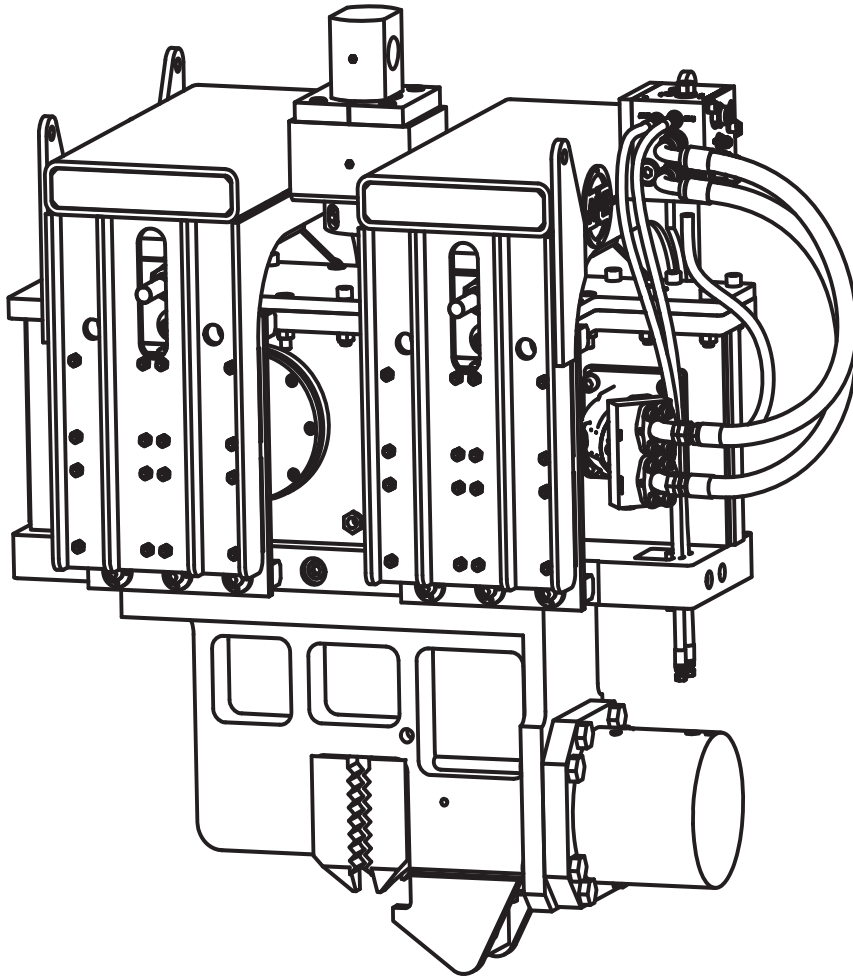

# OPERATION AND MAINTENANCE MANUAL



APE Model 64X

SERIAL NUMBER:

**MODEL 64X VIBRO**



# OPERATION / MAINTENANCE MANUAL

MODEL 64X EXCAVATOR MOUNTED VIBRATORY HAMMER

7032 SOUTH 196th - KENT, WA 98032 - (253) 872-0141 / FAX (253) 872-8710

## Revision Record

Change Number	Page Number	Date	Revision Description
01		11/08/10	PRINTED
02		4/9/14	CORRECTIONS



# **OPERATION / MAINTENANCE MANUAL**

MODEL 64X VIBRATORY HAMMER

7032 SOUTH 196th - KENT, WA 98032 - (253) 872-0141 / FAX (253) 872-8710

## **Preface**

### **General**

This manual covers the **Model 64X Vibratory Driver/Extractors**. The data provided in this manual gives the necessary information to operate and maintain APE equipment. The listed procedures are to be performed by qualified personnel who have an understanding of the equipment and who follow all safety precautions.

### **Guide to Using the Manual**

1. Refer to the Table of Contents for the page location of applicable sections.
2. All weights and measurements in this manual are in both English and Metric units.
3. The manual will be revised as necessary to reflect current information.

### **Abbreviations**

The following are abbreviations used within this manual.

<b>lbs.</b>	= Pounds	<b>HCLW</b>	= High Collar Lock Washer
<b>psi.</b>	= Pounds per Square Inch	<b>P/N</b>	= Part Number
<b>hp.</b>	= Horse Power	<b>SHCS</b>	= Socket Head Cap Screw
<b>gpm.</b>	= Gallons Per Minute		
<b>rpm.</b>	= Revolutions Per Minute		
<b>eng.</b>	= Engine		
<b>cyl.</b>	= Cylinder		
<b>mm.</b>	= Millimeter		
<b>mtg.</b>	= Mounting		
<b>S/N</b>	= Serial Number		
<b>sol.</b>	= Solenoid		

### **Serial Number Locations**

1. **VIBRATOR:** Above and in between the eccentric covers on both sides of the machine.



# **OPERATION / MAINTENANCE MANUAL**

**MODEL 64X VIBRATORY HAMMER**

**7032 SOUTH 196th - KENT, WA 98032 - (253) 872-0141 / FAX (253) 872-8710**

## **TABLE OF CONTENTS**

	Page
<b>Preface</b> .....	<b>4</b>
<b>TABLE OF CONTENTS</b> .....	<b>5</b>
<b>Safety Precautions</b> .....	<b>7</b>
<b>Warranty</b> .....	<b>9</b>
<b>I. GENERAL INFORMATION</b>	
I-1. Machine Features .....	1-1
I-2. Machine Specifications .....	1-2
I-2A. Model 64X Vibro .....	1-2
I-3. General Description of Model 64X Vibro.....	1-3
I-3A. The Suppressor Housing .....	1-4
I-3B. The Vibrator Gearbox.....	1-5
I-3C. The Clamp Attachment.....	1-6
I-3D. Optional Attachments.....	1-7
I-4. Hydraulic Schematic .....	1-8
I-5. Hydraulic Components List .....	1-9
<b>II. MAJOR COMPONENT DEFINITION</b>	
II-1. Model 64X Final Assembly Identification .....	2-2
II-2. Suppressor Identification .....	2-6
II-3. Gearbox Identification .....	2-10
II-4. Sequence Valve Manifold Identification .....	2-12
II-5. Check Valve Manifold Identification .....	2-15
II-6. Clamp Identification .....	2-16
<b>III. LOADING AND UNLOADING</b>	
III-1. Model 64X Vibratory Hammer.....	3-1
III-2. What to do if damaged during shipment .....	3-1
<b>IV. PREPARATION AND OPERATION</b>	
IV-1. Rigging of Vibratory Hammer.....	4-1
IV-2. Installing the Clamp Attachment .....	4-1
IV-3. Plumbing the Vibro Hoses to the Excavator .....	4-2
IV-4. Filling Vibrator Pressure Hose .....	4-3
IV-5. Bleeding the Clamp Attachment Hydraulic Hoses .....	4-3
IV-6. Precautions and Rules for Operation.....	4-4
IV-7. Sequence Valve Settings Prior to Operation.....	4-5
IV-8. Shut-down Procedures .....	4-5



# OPERATION / MAINTENANCE MANUAL

MODEL 64X VIBRATORY HAMMER

7032 SOUTH 196th - KENT, WA 98032 - (253) 872-0141 / FAX (253) 872-8710

The use of the APE Sequence Valve with any APE vibro, regardless of model or size, whether attached to an excavator or run from an APE power unit, must have in place safety chains and/or safety cables attached to any pile regardless of pile type. This is a mandatory safety device required to prevent injury and/or damage by possible failure of clamp close hydraulic pressure for any reason. Loss or reduction of hydraulic clamp pressure may result in dropping a pile unexpectedly.

Picking up piles of any type and moving them from location to location without this safety device is absolutely forbidden. Anytime an APE vibro is attached to a pile of any type, regardless of intended use of the vibro shall always have this safety device attached, no exceptions allowed.

Violation of this basic and standard safety procedure is the sole responsibility of the user and American Piledriving Equipment, Inc shall not be held liable, directly or indirectly for possible results that may occur due to the intentional or unintentional use of our product without this safety device installed.



# OPERATION / MAINTENANCE MANUAL

MODEL 64X VIBRATORY HAMMER

7032 SOUTH 196th - KENT, WA 98032 - (253) 872-0141 / FAX (253) 872-8710

## **Safety Precautions**

(This list of precautions must be followed at all times to ensure personal & equipment safety.)

1. Read this manual from beginning to end before operating or working on this machine.
2. When operating in a closed area, pipe exhaust fumes outside. (**WARNING:** Breathing exhaust fumes can cause serious injury and even death.)
3. When servicing batteries, avoid any type of spark or open flame. Batteries generate explosive gases during charging. There must be proper ventilation when charging batteries.
4. Never Adjust or repair the unit while it is in operation.
5. Make sure the Control Pendant is in the "OFF" position before starting the unit.
6. Remove all tools and electrical cords before starting the unit.
7. Keep oily rags away from the exhaust system.
8. Never store flammable liquids near the engine.
9. Never stand under vibro at any time and keep your eyes on the vibro when it is in operation. Keep a look out for loose bolts or leaking hydraulic lines.
10. Avoid pulling on hose quick dis-connect fittings. Move power unit closer to work if hoses cannot reach. Do not use hoses as a tow line to tug the power unit! If a hose fails at the hydraulic couplers then it is a result of "hose tugging by the pile crew".
11. Avoid kinks in the hoses. Kinks will cut the hose safety factor by 50 percent.
12. Always wear eye and ear protection.
13. Avoid standing downwind of vibrating piles. Dirt and other matter may become airborne and fall into the unprotected eye.
14. Always wear a hardhat, gloves, and safety shoes.
15. Always attach safety line to pile when extracting or hoisting into position.
16. (**WARNING**) Never clamp vibro to pile and dis-connect from crane line. Lay vibro down on ground when not in use.
17. Do not truck power unit with quick disconnect caps and plugs screwed on to fittings unless the caps and plugs have wire rope safety lines attached. Store in storage box under control panel.



# **OPERATION / MAINTENANCE MANUAL**

**MODEL 64X VIBRATORY HAMMER**

**7032 SOUTH 196th - KENT, WA 98032 - (253) 872-0141 / FAX (253) 872-8710**

## **Figure List**

Figure 1-A.	Machine Features .....	1-1
Figure 1-B.	General Description of 64X Vibro. ....	1-3
Figure 1-C.	General Description of Suppressor Housing. ....	1-4
Figure 1-D.	General Description of Vibrator Gearbox. ....	1-5
Figure 1-E.	General Description of Clamp Attachment .....	1-6
Figure 1-F.	Clamp Attachment Hole Configuration.....	1-6
Figure 1-G.	Optional Attachments.....	1-7
Figure 1-H.	Hydraulic Schematic .....	1-8
Figure 2-A.	Component Identification. ....	2-2
Figure 2-B.	Suppressor Assembly .....	2-6
Figure 2-C.	Suppressor Assembly .....	2-7
Figure 2-D.	Gearbox Assembly.....	2-10
Figure 2-E.	Sequence Valve Manifold Assembly .....	2-12
Figure 2-F.	Check Valve Manifold Assembly .....	2-15
Figure 2-G.	Model 150 Clamp Assembly .....	2-16
Figure 4-I.	Vibro Sequence Manifold Layout.....	4-2
Figure 4-J.	Bleeding Clamp Attachment .....	4-3

## **Table List**

Table 1-A.	Model 64X Specs.....	1-2
Table 1-B.	Hydraulic Components List.....	1-9
Table 2-A.	Model 64X Final Assembly .....	2-5
Table 2-B.	Suppressor Assembly .....	2-9
Table 2-C.	Gearbox Assembly.....	2-11
Table 2-D.	Sequence Valve Manifold Assembly .....	2-13
Table 2-E.	Check Valve Manifold Assembly .....	2-15
Table 2-F.	Model 150 Clamp Assembly .....	2-17



# OPERATION / MAINTENANCE MANUAL

MODEL 64X VIBRATORY HAMMER

7032 SOUTH 196th - KENT, WA 98032 - (253) 872-0141 / FAX (253) 872-8710

## **Warranty**

### American Piledriving Equipment, Inc. J&M Foundation Equipment LLC STANDARD WARRANTY

American Piledriving Equipment, Inc./J&M Foundation Equipment LLC (APE/J&M) warrants new products sold by it to be free from defects in material or workmanship for a period of one year after the date of delivery to the first user and subject to the following conditions:

APE/J&M's obligation and liability under this WARRANTY is expressly limited to repairing or replacing at APE/J&M's option, any parts which appear to APE/J&M upon inspection to have been defective in material or

workmanship. Such parts shall be provided at

no cost to the user, at the business establishment of APE/J&M or the authorized APE/J&M distributor of the product during regular working hours. This WARRANTY, shall not apply to component parts or accessories of products not manufactured by APE/J&M and which carry the warranty of the manufacturer thereof, or to normal maintenance (scraped and scived lube and fuel lines, worn cushion material in the drive base) or normal maintenance parts (such as fouled injectors, weakened check valve springs, damaged grease zirts caused by use over time).

Replacement or repair parts installed in the product covered by this WARRANTY are warranted only for the remainder of the warranty as if such parts were original components of said product. APE/J&M makes no other warranty, expressed or implied and makes no warranty of merchantability of fitness for any particular purpose.

APE's obligation under this WARRANTY shall not include any transportation charges, costs of installation, duty, taxes or any other charges whatsoever, or any liability for direct, indirect, incidental or consequential damage or delay. If requested by APE/J&M, products or parts for which a warranty claim is made are to be returned transportation prepaid to APE/J&M. Any improper use, including operation after discovery of defective or worn parts, operation beyond rated capacity, substitution of any parts whatsoever, or parts not approved by APE/J&M or any alteration or repair by others in such manner as in APE/J&M's judgment affects the product materially and adversely, shall void this warranty.

**ANY TYPE OF WELDING ON EQUIPMENT**  
**WILL VOID THE WARRANTY**

Refusal: Vibros: If the pile does not move one foot in 30 seconds of vibro operation at full speed. Resort to a larger vibro. APE/J&M equipment may exceed the refusal driving criteria for short periods of time as may be needed to penetrate hard soil layers or obstacles. In such cases, a heat gun is used to monitor the temperature of the bearings and related components to prevent use of the machine beyond 210 degrees. Contact APE/J&M or your local APE/J&M distributor for special instructions when faced with refusal conditions.

Refusal: Diesels: Do not exceed 10 blows per inch or 120 blows per foot. In cases of setting of the pile it is permitted to increase the blow count to 250 blows per foot, but only for one foot of driving penetration. Pile inspectors should consult the APE factory for permission to exceed these limits. Failure to do so will void the warranty. This standard specification is accepted by the DFI (Deep Foundations Institute) and the PDCA (Pile Contractors Association) and by all manufacturers of pile driving equipment.





# OPERATION / MAINTENANCE MANUAL

MODEL 64X VIBRATORY HAMMER

7032 SOUTH 196th - KENT, WA 98032 - (253) 872-0141 / FAX (253) 872-8710

## I. GENERAL INFORMATION

### I-1. Machine Features

#### APE MODEL 64X VIBRATORY DRIVER/EXTRACTOR

FOR ALL TYPES OF PILE DRIVING AND EXTRACTING

Just 4300 pound  
with excavator  
mounting

56 Tons of  
drive force

20 Ton line  
pull maximum

900 inch pounds -  
very powerful

Rubber elastomers  
smooth

- Can be used under  
water

One piece gear/  
eccentric design  
- No pins, splines or  
keyways

Attachments for  
wood & pipe piles

Drives double &  
single sheets

Clamp fits  
H-beams &  
plates

Visual indicator  
shows crane line  
pull

4 wire hoses prevent  
failures

Motor recessed - out  
of harm's way

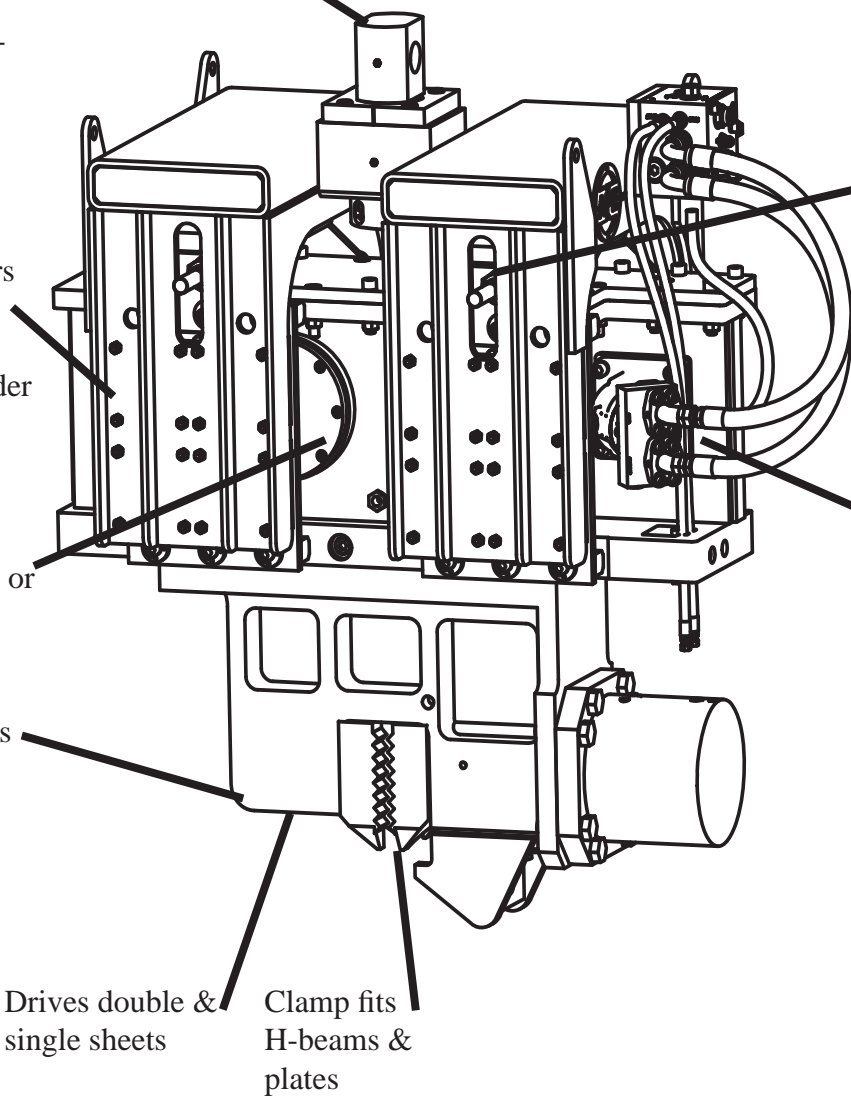

Figure 1-A. Machine Features



# OPERATION / MAINTENANCE MANUAL

MODEL 64X VIBRATORY HAMMER

7032 SOUTH 196th - KENT, WA 98032 - (253) 872-0141 / FAX (253) 872-8710

## I. I. GENERAL INFORMATION (Continued...)

### I-2. Machine Specifications

#### I-2A. Model 64X Vibro

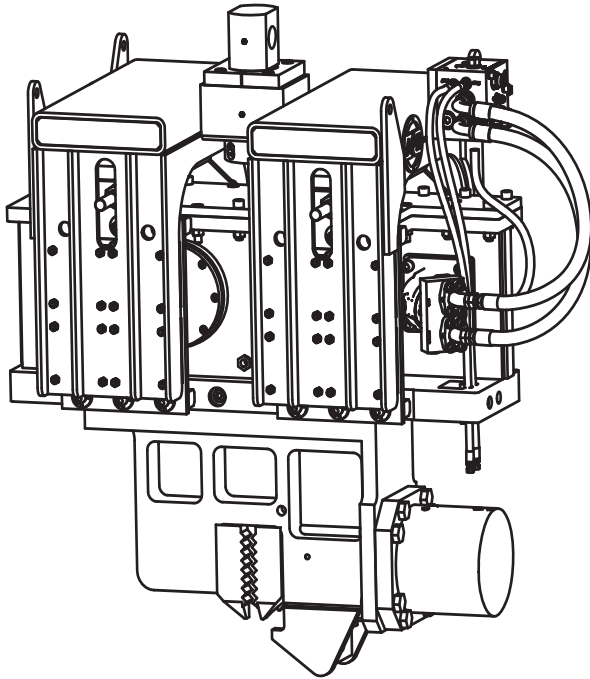

Eccentric Moment	900
Drive Force	56 Tons (498 kN)
Frequency (cpm)	0 - 2400
Amplitude	7/8" (22mm)
Pile Clamp Force	100 Tons (890 kN)
Line Pull for Extraction	20 tons
Bare Vibro Weight	4290 lbs.
Length	71" (1,803 mm)
Width	32.50" (825.5 mm)
Throat Width	13.75" (349.25 mm)
Height	42.31" (1,075 mm)
Height with Clamp*	71" (1,803 mm)

Table 1-A. Model 64X Specs



# OPERATION / MAINTENANCE MANUAL

MODEL 64X VIBRATORY HAMMER

7032 SOUTH 196th - KENT, WA 98032 - (253) 872-0141 / FAX (253) 872-8710

## I. I. GENERAL INFORMATION (Continued...)

### I-3. General Description of Model 64X Vibro

The **APE Model 64X** is a variable frequency vibratory pile driver/extractor designed to drive and extract all types of piles including sheet, pipe, timber, concrete, H-beam, I-beam, and steel plates. In addition, the vibrator can be used for soil compaction, installing well casings, and installation of tie-backs and wick drains.

The Model 64X operates in a frequency range of 0 to 2400 cycles per minute depending on the hydraulic flow and on the hydraulic motors fitted to the gear train. The Model 64X is especially suited for driving or extracting piles that are near buildings or other structures. This is because the Model 64X vibrates at higher frequencies and thus is less damaging to surrounding soils.

The three major parts to the Model 64X are as follows:

- A.) The Suppressor housing. (Excavator suppressor not shown on this page)
- B.) The Gearbox.
- C.) The Clamping Attachment.

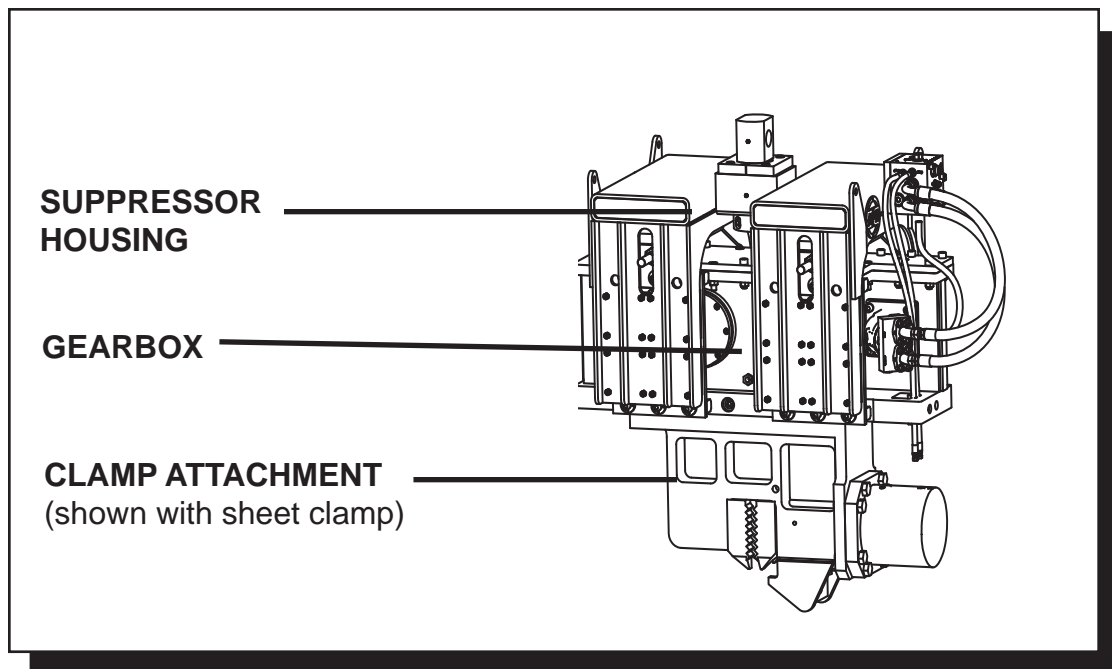

**Figure 1-B. General Description of 64X Vibro.**



# OPERATION / MAINTENANCE MANUAL

MODEL 64X VIBRATORY HAMMER

7032 SOUTH 196th - KENT, WA 98032 - (253) 872-0141 / FAX (253) 872-8710

## I. I. GENERAL INFORMATION (Continued...)

### I-3A. The Suppressor Housing

The suppressor housing of the **Model 64X APE Vibrator** is the housing that wraps around the sides of the vibro that attaches to the excavator. It is designed to absorb the vibration generated from the vibrator gearbox.

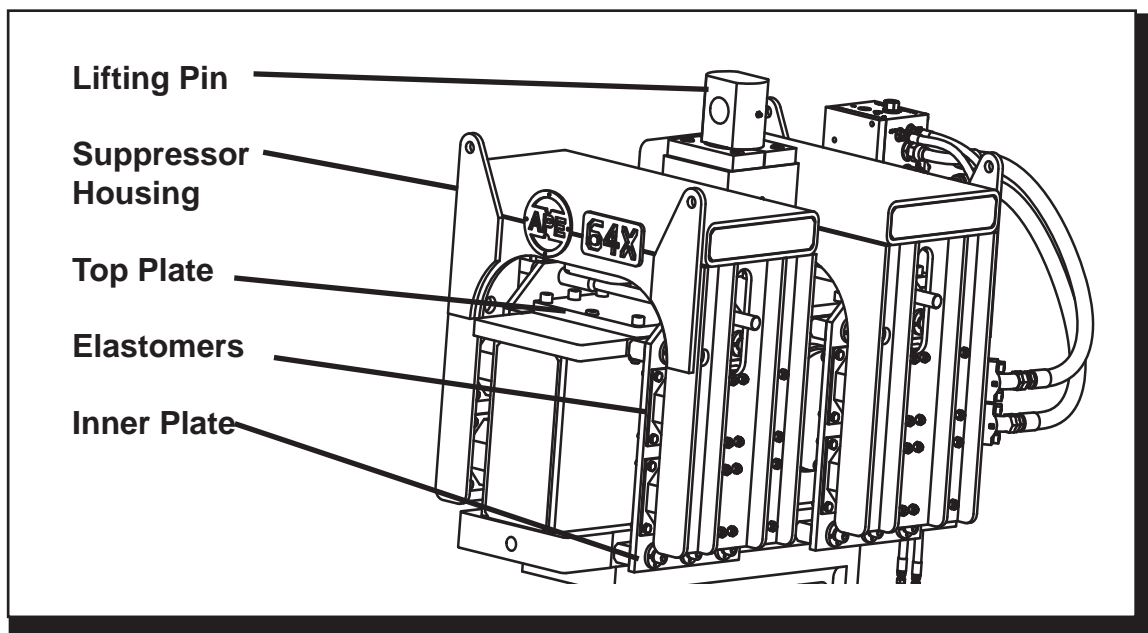

Figure 1-C. General Description of Suppressor Housing.



# OPERATION / MAINTENANCE MANUAL

MODEL 64X VIBRATORY HAMMER

7032 SOUTH 196th - KENT, WA 98032 - (253) 872-0141 / FAX (253) 872-8710

## I. GENERAL INFORMATION (Continued...)

### I-3B. The Vibrator Gearbox

The vibrator gearbox contains two high amplitude eccentric weights cast in one piece with the gear. The counterweight is filled, and therefore, enhanced with lead to increase eccentric moment. This design is unique to the industry and was developed by the engineers of APE to solve a number of problems associated with other types of vibrator machines. Both the eccentric and the drive gear have been helically cut to provide high speed operation with reduced noise and wear. Vibration is caused by the vertical movement created when the eccentrics are rotated. The eccentric and drive gear are driven in line by one Volvo motor mounted on the outside face of the gearbox. The motor is recessed for maximum protection. The eccentrics rotate on two shafts housed by four giant spherical bearings. The gears and bearings receive lubrication as a result of the fluid splashing inside the gearbox when the gears are rotated. The oil level is quickly determined by looking at the site gauge. The Model 64X can be operated under water to a depth of 30 feet without modifications. (Consult factory for depths below 30 feet.)

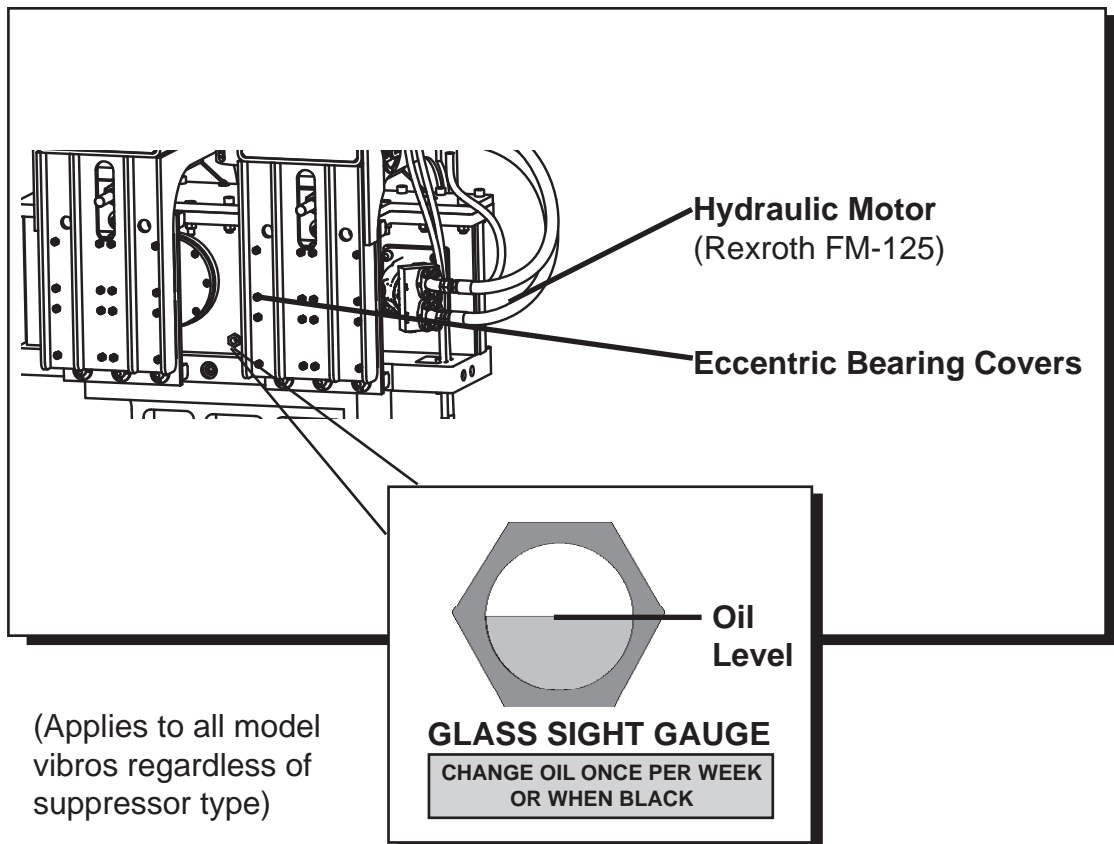

Figure 1-D. General Description of Vibrator Gearbox.



# OPERATION / MAINTENANCE MANUAL

MODEL 64X VIBRATORY HAMMER

7032 SOUTH 196th - KENT, WA 98032 - (253) 872-0141 / FAX (253) 872-8710

## I. GENERAL INFORMATION (Continued...)

### I-3C. The Clamp Attachment

The APE 64X comes with a **standard sheet pile clamp attachment**. The clamp contains two gripping jaws. One is "fixed" and one is "moveable." A large hydraulic cylinder operates the moveable jaw with up to 250 tons of clamping force depending on clamp pump relief pressure. The jaws open and close by turning a switch on the remote control pendant or may be operated by turning the switch at the main control panel mounted behind one of the doors on the power unit. The valve can be manually operated with a screwdriver if all electrical fails. **The APE standard sheet pile clamp** can be fitted with jaws to fit many different types of piles including sheet piles, H-Beams, steel plates, steel rods, pipe piles, wood piles, and concrete piles. (Contact APE or your local APE distributor for more information on clamp attachments for special pile types.)

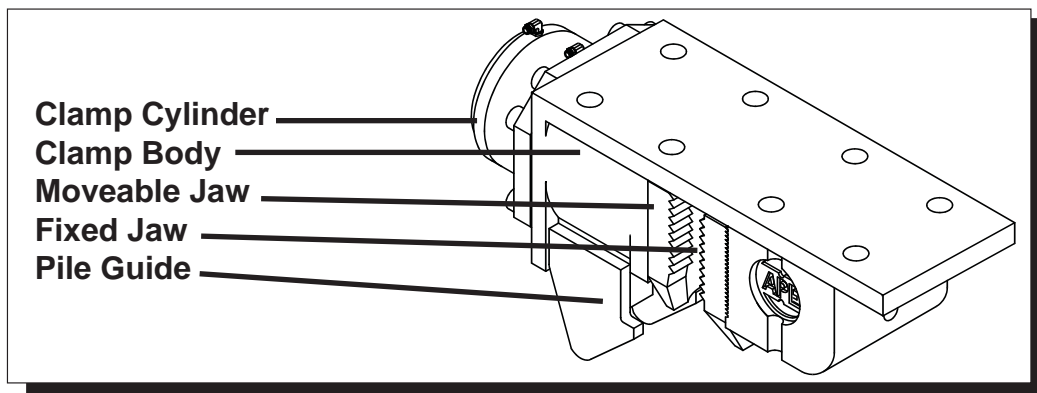
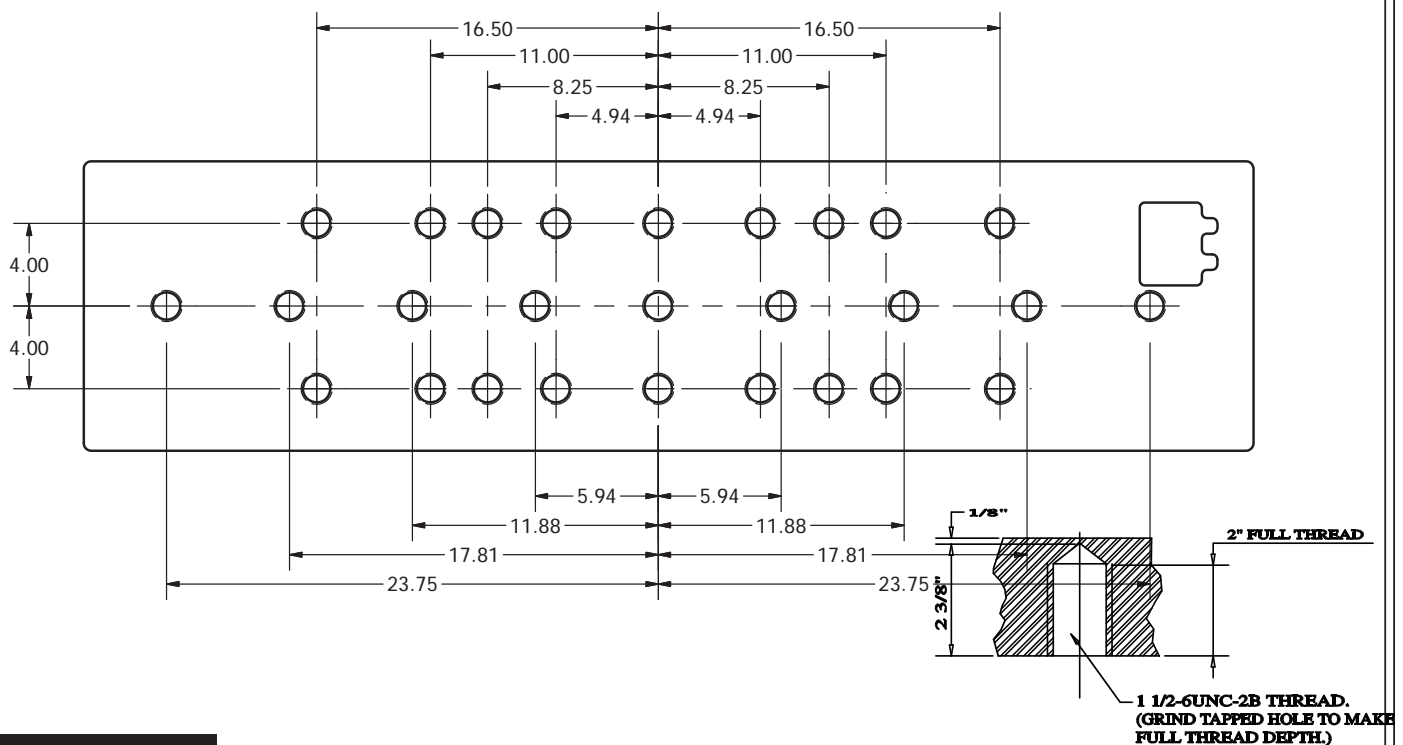

Figure 1-E. General Description of Clamp Attachment





# OPERATION / MAINTENANCE MANUAL

MODEL 64X VIBRATORY HAMMER

7032 SOUTH 196th - KENT, WA 98032 - (253) 872-0141 / FAX (253) 872-8710

## I. GENERAL INFORMATION (Continued...)

### I-3D. Optional Attachments

The following are some of the optional attachments for the APE Vibratory Hammers. (Contact APE or your local APE distributor for more information about these and other available equipment.)

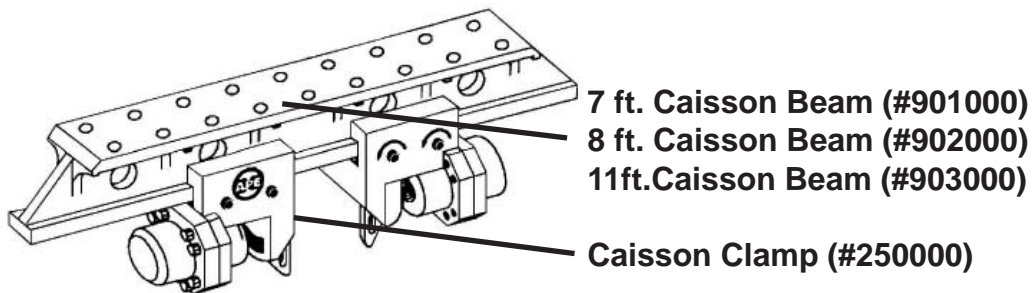

**APE CAISSON CLAMP**

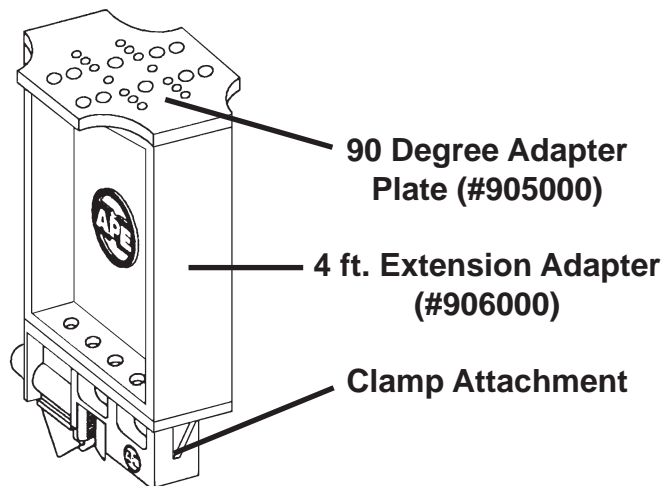

**APE 90 DEGREE ADAPTER WITH EXTENSION**

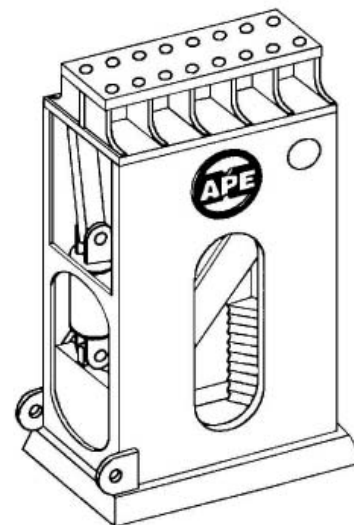

**APE DELUXE CONCRETE / WOOD CLAMP (#907000)**

**Figure 1-G. Optional Attachments**

### I. GENERAL INFORMATION (Continued...)

#### I-4. Hydraulic Schematic

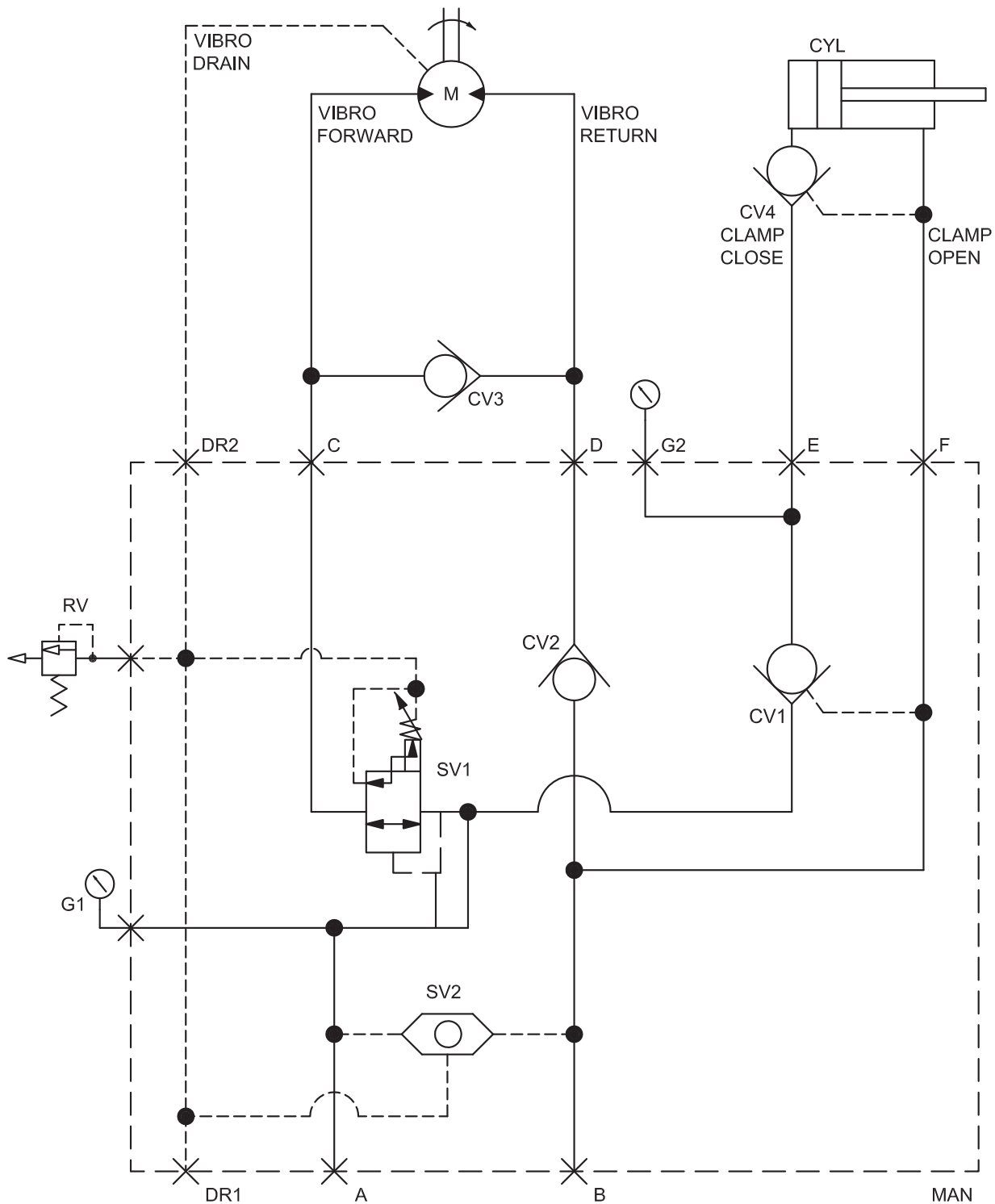

Figure 1-H. Hydraulic Schematic





# OPERATION / MAINTENANCE MANUAL

MODEL 64X VIBRATORY HAMMER

7032 SOUTH 196th - KENT, WA 98032 - (253) 872-0141 / FAX (253) 872-8710

## I. GENERAL INFORMATION (Continued...)

### I-5. Hydraulic Components List

Notation	Description	Part Number	Page Number
A .....	Vibro Forward Port to Excavator .....		
B .....	Vibro Return / Clamp Open Port to Excavator .....		
C .....	Vibro Forward Port to Vibro .....		
CV1 .....	P.O. Check Valve - Manifold .....		
CV2 .....	Check Valve .....		
CV3 .....	Check Valve - Vibrator .....		
CV4 .....	P.O. Check Valve - Clamp Cylinder .....		
CYL .....	Clamp Cylinder .....		
D .....	Vibro Return Port to Vibro .....		
DR1 .....	Drain Port - Case Drain to Excavator .....		
DR2 .....	Drain Port - Case Drain to Vibro Motor .....		
E .....	Clamp Close Port to Clamp .....		
F .....	Clamp Open Port to Clamp .....		
G1 .....	Gage Port - Forward .....		
G2 .....	Gage Port - Close Clamp .....		
M .....	Motor .....		
MAN .....	Machined Manifold .....		
RV .....	Relief Valve / Case Drain Pop-off .....		
SV1 .....	Sequence Valve .....		
SV2 .....	Shuttle Valve .....		

**Table 1-B. Hydraulic Components List**



# OPERATION / MAINTENANCE MANUAL

MODEL 64X VIBRATORY HAMMER

7032 SOUTH 196th - KENT, WA 98032 - (253) 872-0141 / FAX (253) 872-8710

## II. MAJOR COMPONENT DEFINITION

### II-1. Model 64X Final Assembly Identification

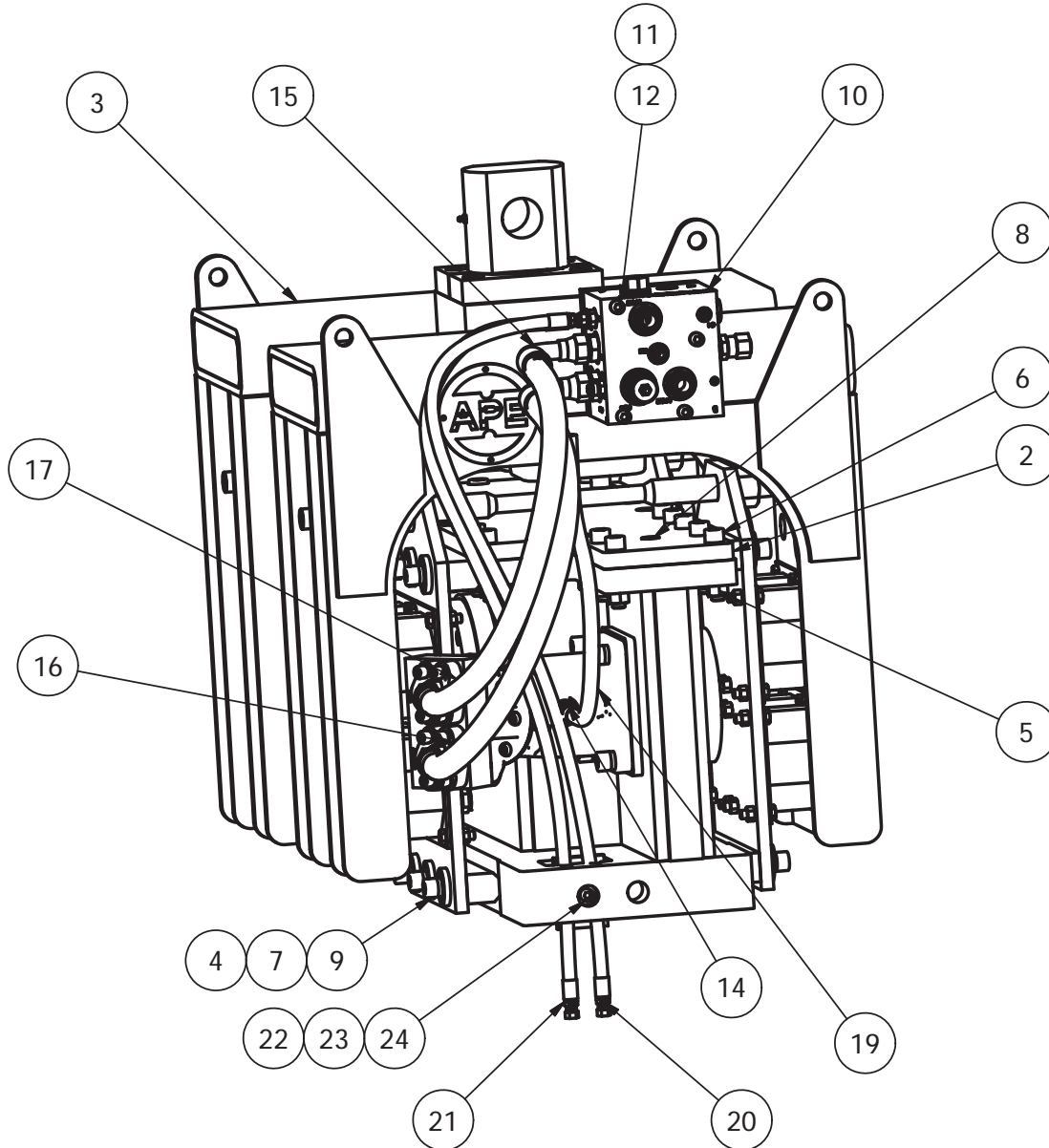

Figure 2-A. Component Identification.



# OPERATION / MAINTENANCE MANUAL

MODEL 64X VIBRATORY HAMMER

7032 SOUTH 196th - KENT, WA 98032 - (253) 872-0141 / FAX (253) 872-8710

## II. MAJOR COMPONENT DEFINITION (Continued...)

### II-1. Model 64X Final Assembly Identification

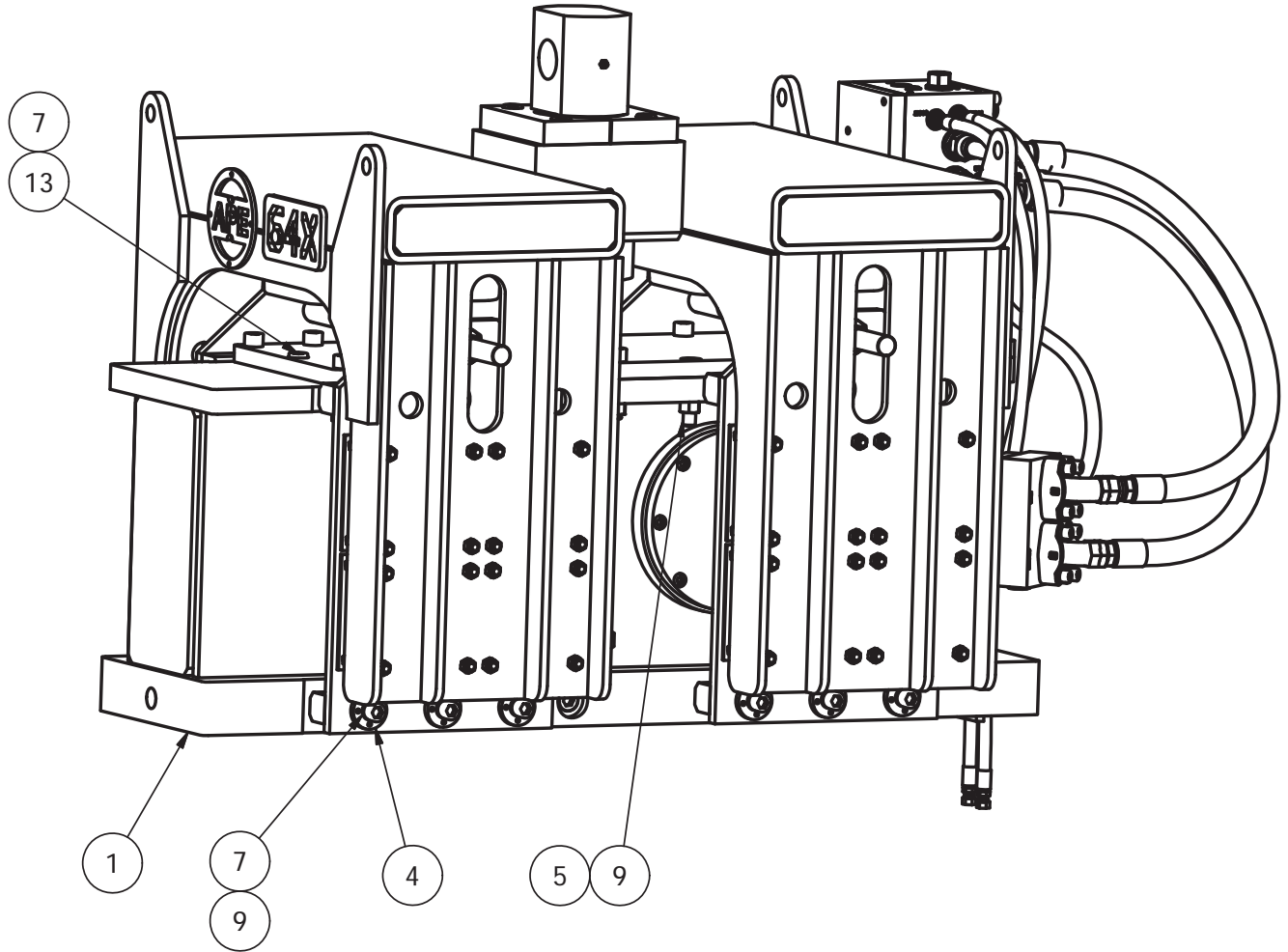



# OPERATION / MAINTENANCE MANUAL

MODEL 64X VIBRATORY HAMMER

7032 SOUTH 196th - KENT, WA 98032 - (253) 872-0141 / FAX (253) 872-8710



# OPERATION / MAINTENANCE MANUAL

MODEL 64X VIBRATORY HAMMER

7032 SOUTH 196th - KENT, WA 98032 - (253) 872-0141 / FAX (253) 872-8710

## II. MAJOR COMPONENT DEFINITION (Continued...)

### II-1. Model 64X Final Assembly Identification

PARTS LIST			
ITEM	QTY	STOCK NUMBER	DESCRIPTION
1	1	113001B	GEAR BOX ASM
2	1		COVER PLATE
3	1		SUPPRESSOR ASM
4	24	1001066	DOWEL PIN
5	24		0.75-10UNC STOVER NUT
6	18	400045	0.75-10UNC X 3.50 SHCS
7	25	400727	0.75 HI COLLAR LOCK WASHER
8	1	100183	FITT2P-12P
9	30		0.75-10UNC X 3.25 SHCS
10	1		SEQUENCE VALVE MANIFOLD ASM
11	4		0.50 HI COLLAR LOCK WASHER
12	4		0.50-13UNC X 7.00 SHCS
13	1		0.75-10UNC X 1.75 LG SHCS
14	1	100139	FITT2S-08M08R000-000H001
15	2		HOSE END #16 JIC SWIVEL 90
16	1		HOSE100R13J016J916L04400
17	1		HOSE100R13J016J916L04400
18	1		HOSE END #8 JIC SWIVEL 90
19	1		HOSE050R02J008J008L03200
20	1		HOSE038R02J006J006L05400
21	1		HOSE038R02J006J006L05400
22	1		HOSE CLAMP PLATE
23	1		0.50-13UNC STOVER NUT
24	1	130235	0.50-13UNC X 3.00 SHCS

**Table 2-A. Model 64X Final Assembly**



# OPERATION / MAINTENANCE MANUAL

MODEL 64X VIBRATORY HAMMER

7032 SOUTH 196th - KENT, WA 98032 - (253) 872-0141 / FAX (253) 872-8710

## II. MAJOR COMPONENT DEFINITION (Continued...)

### II-2. Suppressor Identification

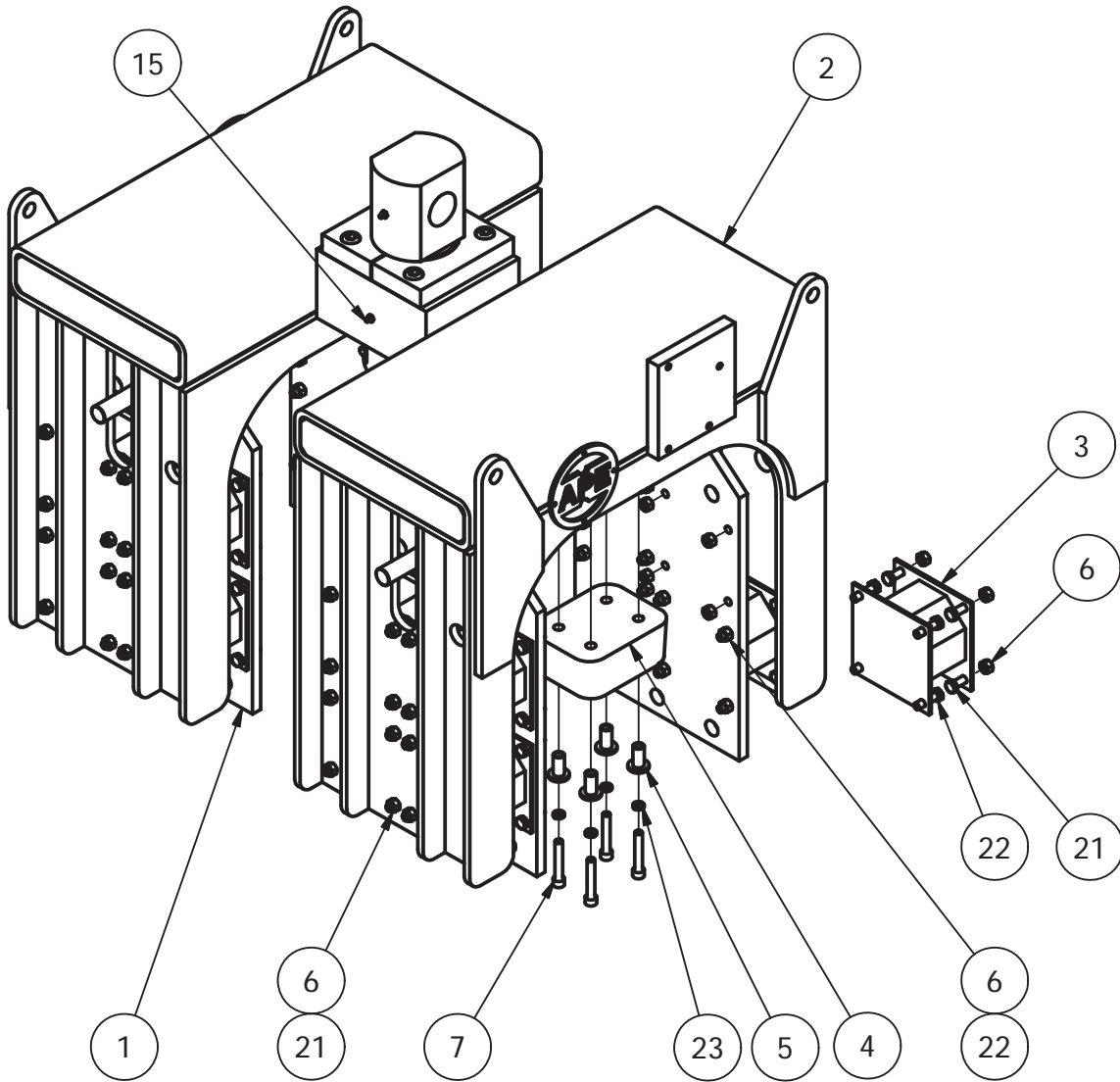

Figure 2-B. Suppressor Assembly



# OPERATION / MAINTENANCE MANUAL

MODEL 64X VIBRATORY HAMMER

7032 SOUTH 196th - KENT, WA 98032 - (253) 872-0141 / FAX (253) 872-8710

## II. MAJOR COMPONENT DEFINITION (Continued...)

### II-2. Suppressor Identification

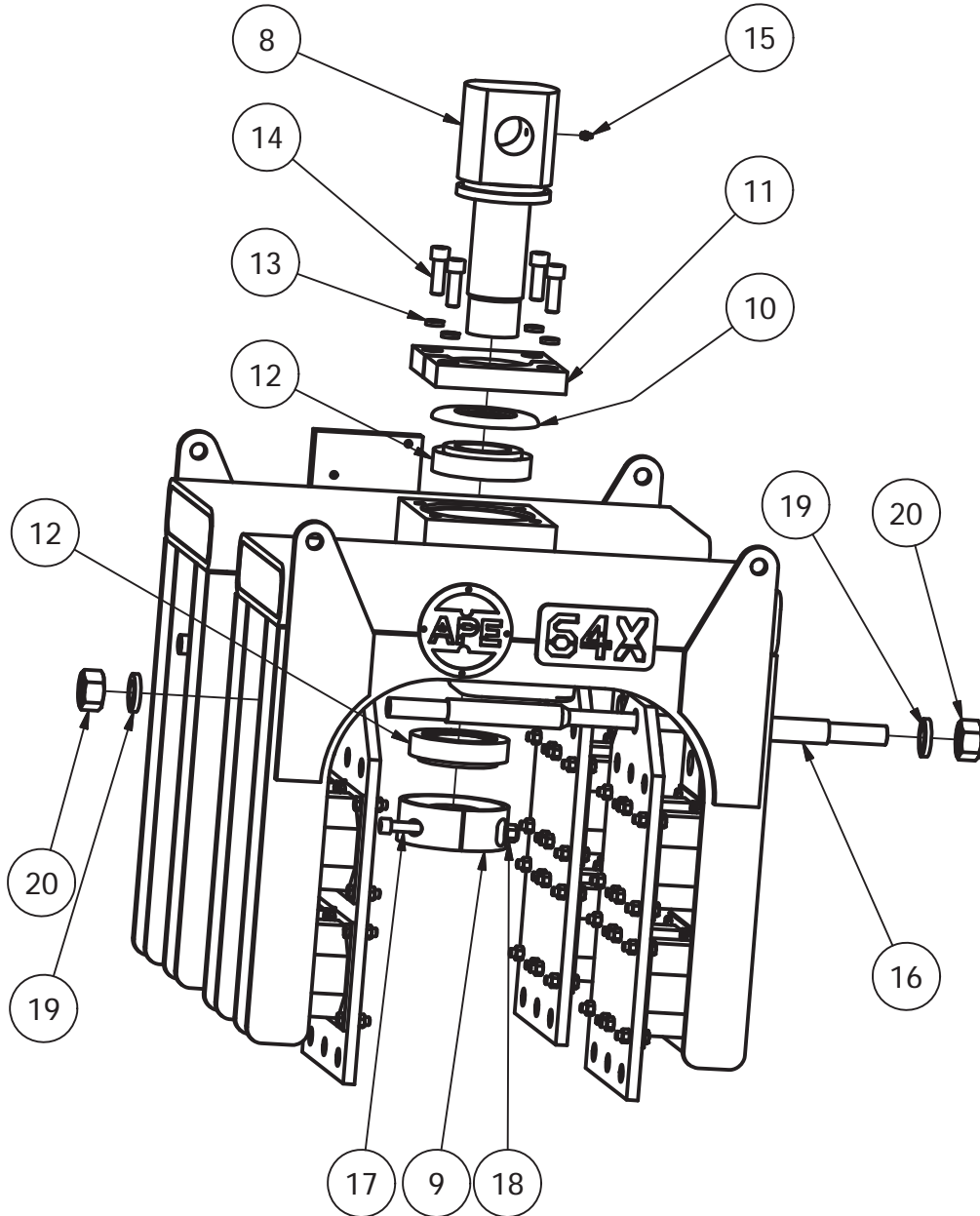

Figure 2-C. Suppressor Assembly



# OPERATION / MAINTENANCE MANUAL

MODEL 64X VIBRATORY HAMMER

7032 SOUTH 196th - KENT, WA 98032 - (253) 872-0141 / FAX (253) 872-8710





# OPERATION / MAINTENANCE MANUAL

MODEL 64X VIBRATORY HAMMER

7032 SOUTH 196th - KENT, WA 98032 - (253) 872-0141 / FAX (253) 872-8710

## II. MAJOR COMPONENT DEFINITION (Continued...)

### II-2. Suppressor Identification

PARTS LIST			
ITEM	QTY	STOCK NUMBER	DESCRIPTION
1	4		INNER PLATE
2	1		OUTER SUPPRESSOR
3	16	311004	ELASTOMER
4	4		DOCK BUMPER
5	16		DOCK BUMP SPACER
6	128		0.50-13UNC STOVER NUT
7	16	130235	0.50-13UNC X 3.00 SHCS
8	1		STUD
9	1		NUT
10	1	130603	SHIELD
11	1		SAFETY CATCH
12	2	130565	BEARING
13	4	140223	0.75 HI COLLAR LOCK WASHER
14	4		0.75-10UNC X 2.25 SHCS
15	2		GREASE FITTING 0.13 NPT
16	2		SAFETY ROD
17	1		0.63-11UNC X 5.50 LG SHCS
18	1		0.63-11UNC ESNA NUT
19	4		1.50 LOCK WASHER
20	4		1.50-6 UNC HEX NUT
21	64	100614	0.50-13UNC X 1.50 LG HHCS
22	64		0.50-13UNC X 1.75 LG HHCS
23	16		0.50 HI COLLAR LOCK WASHER

**Table 2-B. Suppressor Assembly**

### II. MAJOR COMPONENT DEFINITION (Continued...)

#### II-3. Gearbox Identification

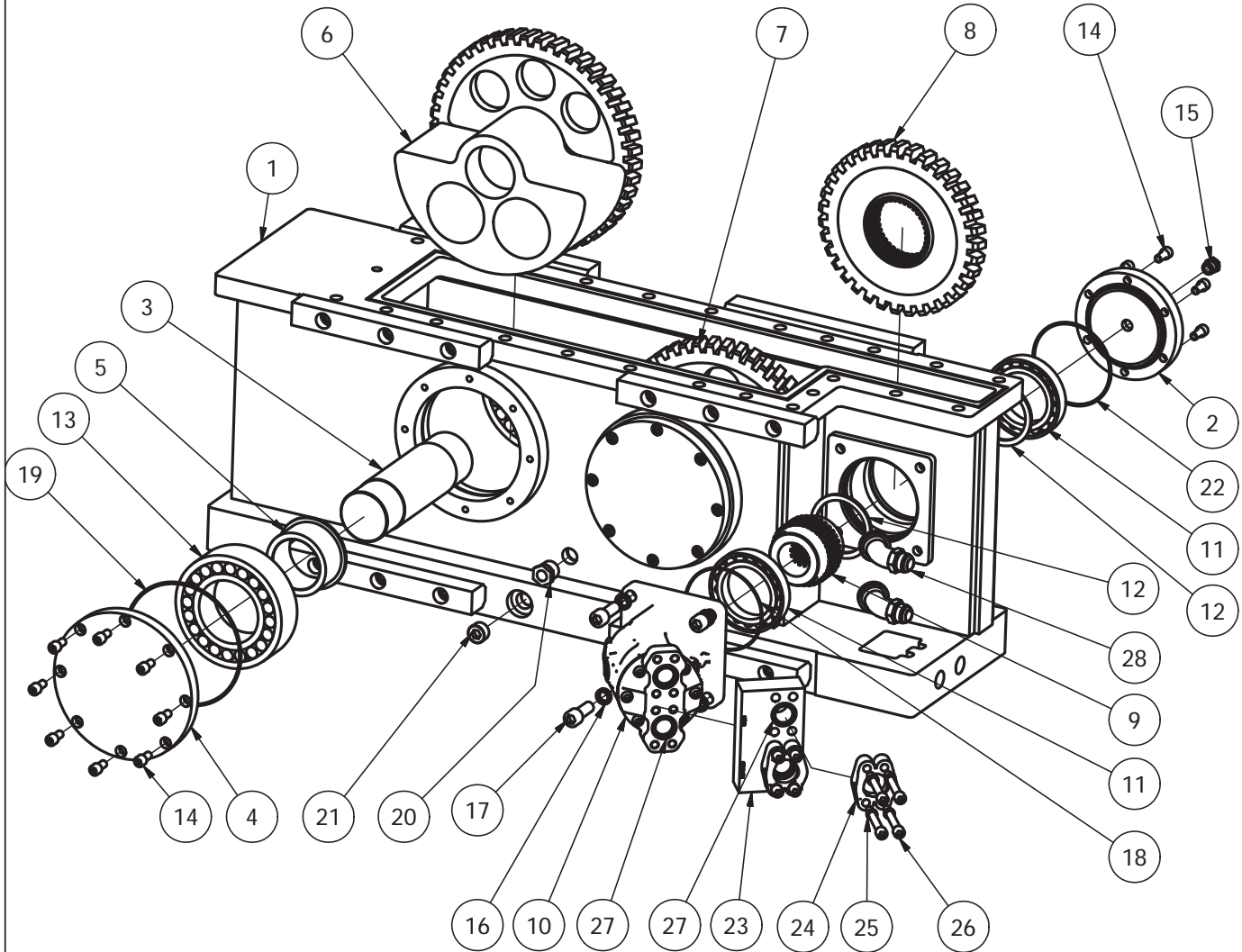

Figure 2-D. Gearbox Assembly



# OPERATION / MAINTENANCE MANUAL

MODEL 64X VIBRATORY HAMMER

7032 SOUTH 196th - KENT, WA 98032 - (253) 872-0141 / FAX (253) 872-8710

## II. MAJOR COMPONENT DEFINITION (Continued...)

### II-3. Gearbox Identification

PARTS LIST			
ITEM	QTY	STOCK NUMBER	DESCRIPTION
1	1		GEAR BOX FRAME
2	1	122005	BEARING COVER w/ BREATHER PORT
3	2	111003B	ECCENTRIC SHAFT
4	4	111004B	BEARING COVER
5	4	111005	BEARING SLEEVE
6	1	141007F	ECCENTRIC LEFT HAND
7	1	141007F	ECCENTRIC LEFT HAND
8	1	111007BF	DRIVE GEAR LEFT HAND
9	1	122010	GEAR CARRIER
10	1	122001A	AA2FM125 MOTOR
11	2	122002	MOTOR BEARING
12	2	122009	GEAR SPACER
13	4	181001A	ECCENTRIC BEARING
14	38	100445	0.50-13UNC X 1.00 SHCS
15	1	122015	GEAR BOX BREATHER
16	4	400727	0.75 HI COLLAR LOCK WASHER
17	4	400069	0.75-10UNC X 2.00 SHCS
18	1	352113	2-163 O-RING
19	4		2-248 O-RING
20	1	123005	SIGHT GLASS
21	1	123004	1" MAG PIPE PLUG
22	1		2-258 O-RING
23	1	112003E	CHECK VALVE MANIF ASM
24	2	110986	20 SPLIT FLANGE CODE 62
25	8		0.50 HI COLLAR LOCK WASHER
26	8	100025	0.50-13UNC X 4.00 SHCS
27	4	100037	2-222 O-RING
28	2		FITT2V-20H16M

Table 2-C. Gearbox Assembly



# OPERATION / MAINTENANCE MANUAL

MODEL 64X VIBRATORY HAMMER

7032 SOUTH 196th - KENT, WA 98032 - (253) 872-0141 / FAX (253) 872-8710

## II. MAJOR COMPONENT DEFINITION (Continued...)

### II-4. Sequence Valve Manifold Identification

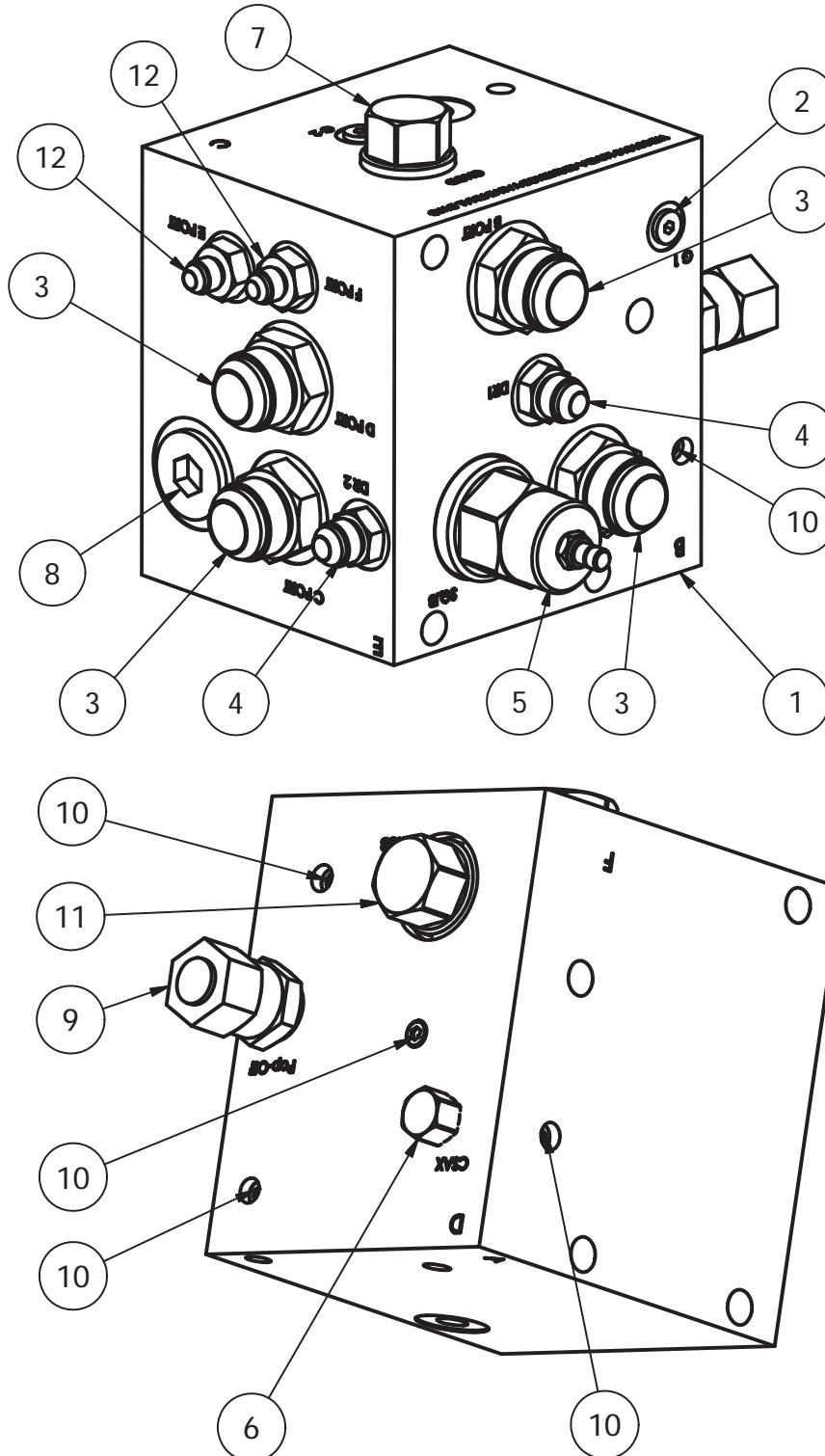

Figure 2-E. Sequence Valve Manifold Assembly



# **OPERATION / MAINTENANCE MANUAL**

MODEL 64X VIBRATORY HAMMER

7032 SOUTH 196th - KENT, WA 98032 - (253) 872-0141 / FAX (253) 872-8710

## **II. MAJOR COMPONENT DEFINITION (Continued...)**

### **II-4. Sequence Valve Manifold Identification**

PARTS LIST			
ITEM	QTY	STOCK NUMBER	DESCRIPTION
1	1		SEQUENCE VALVE MANIFOLD
2	2	110935	FITT2P-04R
3	4		FITT2S-16M16R000-0000001
4	2	100139	FITT2S-08M08R000-000H001
5	1		SEQUENCE VALVE
6	1		SHUTTLE VALVE
7	1		CHECK VALVE
8	1		FITT2P-16R
9	1	321009	POP OFF RELIEF
10	8	100646	FITT2P-02P
11	1		P O CHECK VALVE
12	2		FITT2S-06M08R

**Table 2-D. Sequence Valve Manifold Assembly**



# OPERATION / MAINTENANCE MANUAL

MODEL 64X VIBRATORY HAMMER

7032 SOUTH 196th - KENT, WA 98032 - (253) 872-0141 / FAX (253) 872-8710



# OPERATION / MAINTENANCE MANUAL

MODEL 64X VIBRATORY HAMMER

7032 SOUTH 196th - KENT, WA 98032 - (253) 872-0141 / FAX (253) 872-8710

## II. MAJOR COMPONENT DEFINITION (Continued...)

### II-5. Check Valve Manifold Identification

112003E

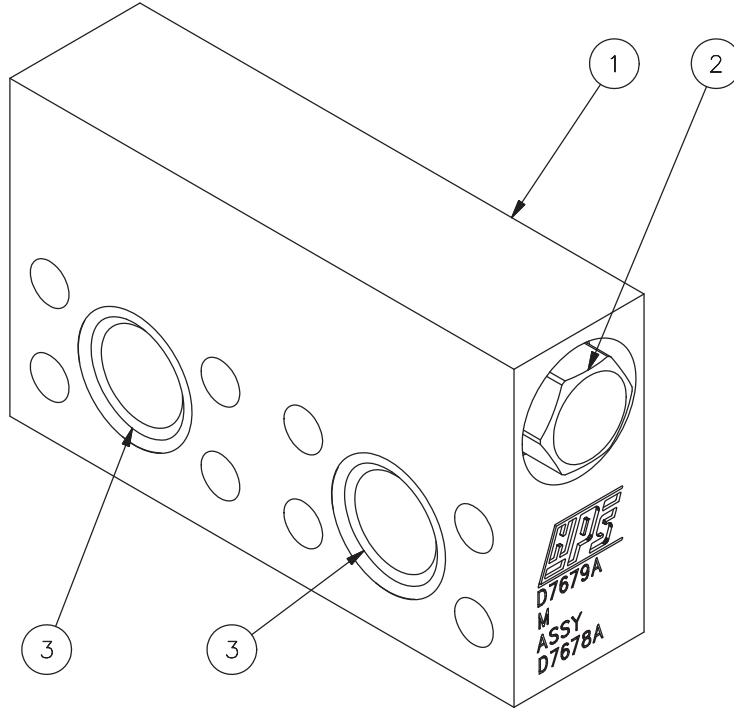

Figure 2-F. Check Valve Manifold Assembly

Parts List			
ITEM	QTY	STOCK NUMBER	DESCRIPTION
1	1	325105	CHECK VALVE MANIFOLD
2	1	352107	CHECK VALVE
3	2	100037	2-222 O-RING

Table 2-E. Check Valve Manifold Assembly

### II. MAJOR COMPONENT DEFINITION (Continued...)

#### II-6. Clamp Identification

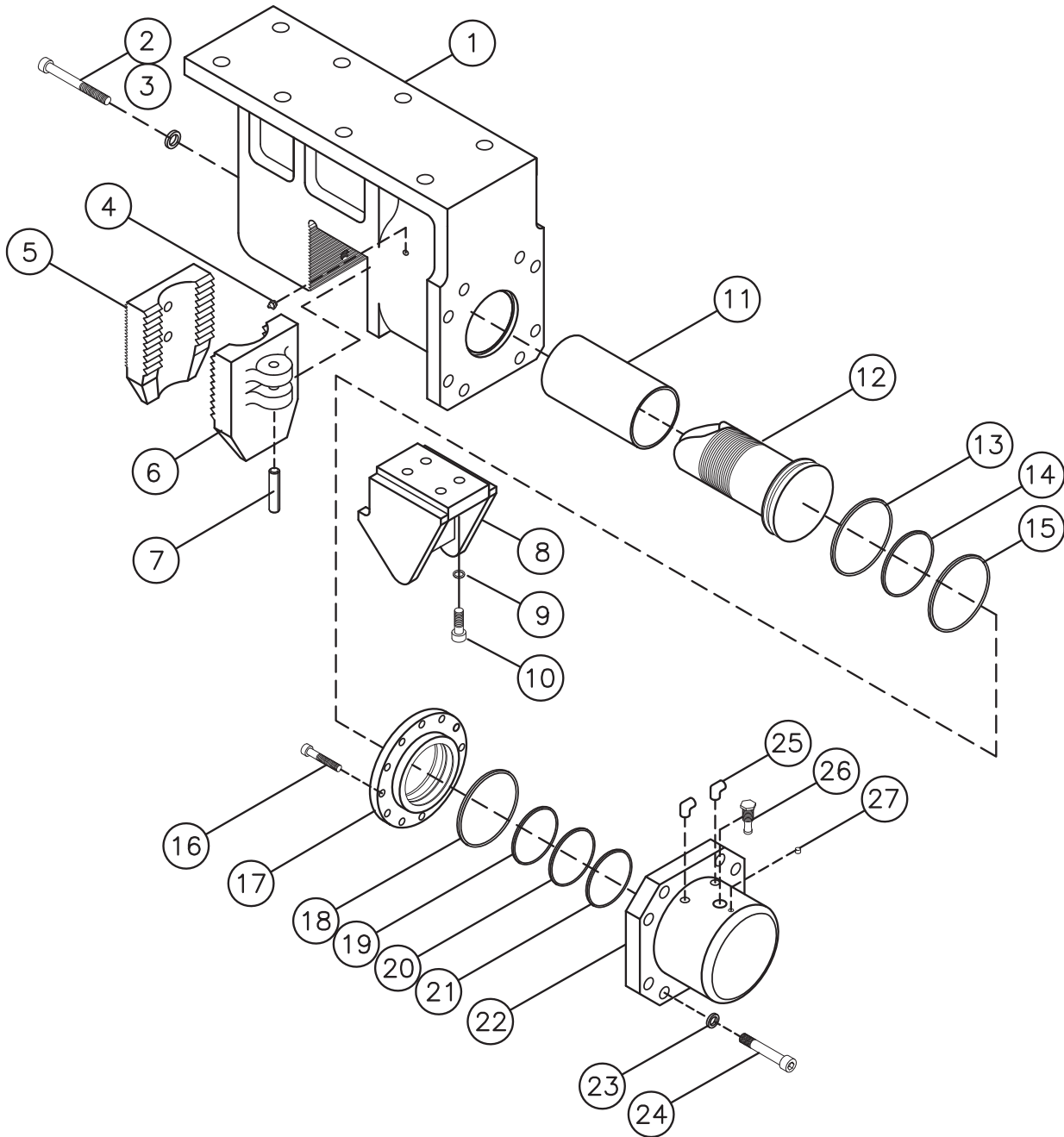

Figure 2-G. Modell 50 Clamp Assembly





# OPERATION / MAINTENANCE MANUAL

MODEL 64X VIBRATORY HAMMER

7032 SOUTH 196th - KENT, WA 98032 - (253) 872-0141 / FAX (253) 872-8710

## II. MAJOR COMPONENT DEFINITION (Continued...)

### II-6. Clamp Identification

<u>ITEM</u>	<u>QTY</u>	<u>DESCRIPTION</u>	<u>PART #</u>
1	1	Clamp Body	221019
2	2	Bolt-SHCS 1" NC X 9"	124206
3	2	1" High Collar Lock Washer	124207
4	1	1/8" Grease Zerk	221001
5	1	Fixed Jaw	221011
6	1	Moveable Jaw	221005
7	1	Jaw Pin	221002
8	1	Sheet Pile Guide Assy.	221017
9	4	1" High Collar Lock Washer	124207
10	4	Bolt-SHCS 1" NC X 3"	124208
11	1	Plastic Sleeve	222020
12	1	Piston / Rod	222007A
13	1	Parker O-Ring R-5100-128	222010
14	1	Parker Expander #442	222010
15	1	Parker Molygard W2-8000-750	222010
16	12	Bolt-SHCS 5/8 NF (Machined)	124209
17	1	Cylinder Gland	222302
18	1	Parker O-Ring 2-367 w/ 8-367	222010
19	1	Parker Wiper SH959-53	222010
20	1	Parker Polypak 2500-6000-375B	222010
21	1	Parker Molygard W2-6250-750	222010
22	1	Clamp Cylinder	222001
23	8	1-1/4" High Collar Lock Washer	124205
24	8	Bolt-SHCS 1-1/4" NF x 3-1/2"	124204
25	2	#6 SAE - #6 JIC 45° Fitting	222002
26	1	Check Valve	222016
27	1	#6 SAE Allen Plug	222017

Note: All seals & o-rings are part of kit 222010

**Table 2-F. Model 50 Clamp Assembly**



# **OPERATION / MAINTENANCE MANUAL**

MODEL 64X VIBRATORY HAMMER

7032 SOUTH 196th - KENT, WA 98032 - (253) 872-0141 / FAX (253) 872-8710

## **III. LOADING AND UNLOADING**

### **III-1. Model 64X Vibratory Hammer**

The APE 64X vibrator is normally shipped laying flat on the trailer deck. Lift the vibrator by rigging one line to the lifting pin and one line around the clamp attachment lifting the vibro. Avoid smashing hydraulic lines. Vibro should be loaded with hydraulic motor down facing the deck and breather valves facing the sky. Before the truck has left, carefully inspect the machine and hoses for any missing equipment or sign of damage that may have occurred during shipment or unloading.

### **III-2. What to do if damaged during shipment**

In the event of damage, notify the trucking agent at once. Note all damage on the bill of lading. Fax the information as soon as possible, any delay may make it impossible to find the responsible party



# OPERATION / MAINTENANCE MANUAL

MODEL 50E VIBRATORY HAMMER

7032 SOUTH 196th - KENT, WA 98032 - (253) 872-0141 / FAX (253) 872-8710

## IV. PREPARATION AND OPERATION

### IV-1. Rigging of Vibratory Hammer

A yoke needs to be used to connect the stud to the excavator. This yoke needs to be sized to match the pin of the excavator and the stud pin. The required strength of this yoke depends on the capacity of the excavator and the work to be carried out.

### IV-2. Installing the Clamp Attachment

The Vibro is fitted with a standard sheet clamp at the factory. However, several types of clamps are used on APE vibros to fit many different types of piles. A step by step procedure is provided as follows:

- 1.) Clean all drilled and tapped threads on the bottom surface of the gearbox. Use a 1 1/2"UNC tap to clean any rusted threads and blow out any remaining fragments with compressed air. If there is a cutting torch on the jobsite then use the oxygen setting to blast the threads clean. Hold a rag over the tapped hole to prevent flying dirt from blasting into your eyes.
- 2.) Clean the machined bottom surface of the gearbox and prepare to mount the clamp. If the clamp bolts should ever break, check the machined surface with a straight edge to make sure it is true and flat.
- 3.) Clean the machined surface of clamp. Eye-ball the entire surface for damage. Make sure the surface is flat and void of all dirt.
- 4.) Start by getting the center bolt in first and work outwards. Do not tighten bolts until you have all of the bolts started.
- 5.) Tighten bolts using a six-foot cheater pipe. If you do not have a cheater pipe then use a sledge hammer.
- 6.) Go around all bolts at least three times making sure they are tight.
- 7.) After vibrating the first pile, check the bolts again.
- 8.) If one bolt holding the clamp breaks, replace them all since they may be weak or cracked.

**WARNING:** Do not use grade five bolts. All bolts should be allen head cap screw bolts. If one bolt breaks then the others are damaged and must be replaced. Never drive piles if one bolt is broken. Bolts break only because they were not tight and the crew neglected to check them. A good operator insists that every bolt is checked twice daily.



# OPERATION / MAINTENANCE MANUAL

MODEL 50E VIBRATORY HAMMER

7032 SOUTH 196th - KENT, WA 98032 - (253) 872-0141 / FAX (253) 872-8710

## IV. PREPARATION AND OPERATION (Continued...)

### IV-3. Plumbing the Vibro Hoses to the Excavator

There are three hoses leading from the vibro that must be connected to the excavator to begin operation see below. There are two big hoses and one smaller hose. The hoses attach to the excavator by connecting to the manifold on the vibro. Please use the following diagram when installing the hoses to the manifold.

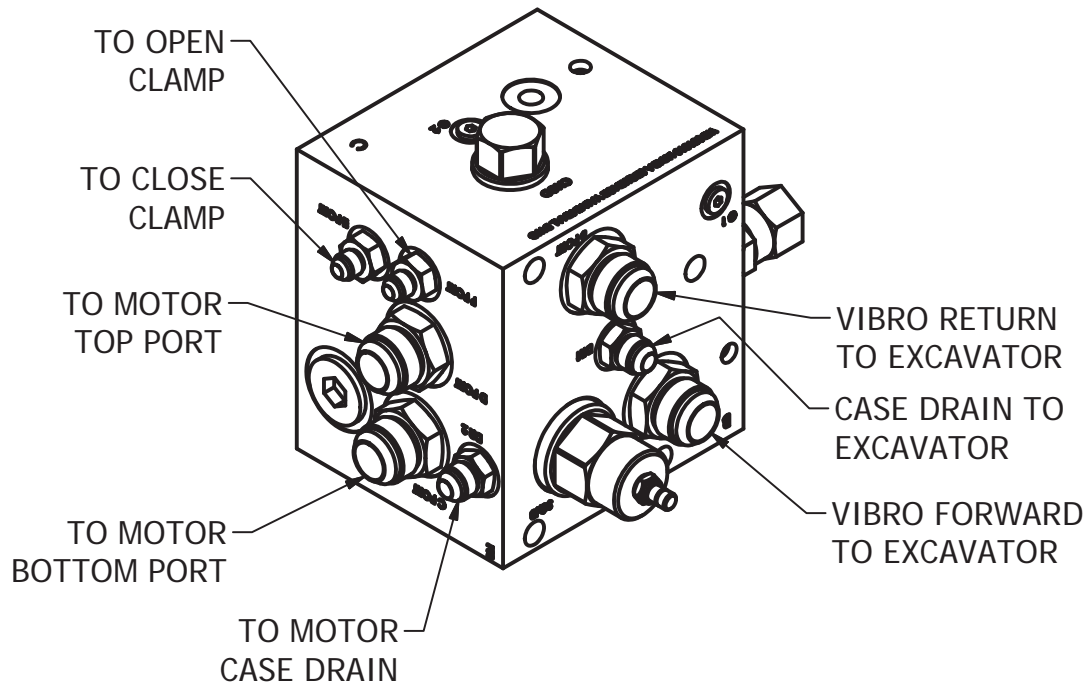

Figure 4-1. Vibro Sequence Manifold Layout



# OPERATION / MAINTENANCE MANUAL

MODEL 50E VIBRATORY HAMMER

7032 SOUTH 196th - KENT, WA 98032 - (253) 872-0141 / FAX (253) 872-8710

## IV. PREPARATION AND OPERATION (Continued...)

### IV-4. Filling Vibrator Pressure Hose

The vibrator is shipped with the hoses filled with oil. However, if the unit has been sitting for a long period of time or if a damaged hose has been replaced with a new one, then the hoses must be filled. Hook up all the hoses to the power unit (see Figure 4-A.). Start the excavator and let it run for ten minutes before running the vibro. The hoses will fill up by themselves in ten minutes even if the vibro is not in the vibrate mode.

### IV-5. Bleeding the Clamp Attachment Hydraulic Hoses

If the opening and closing of the jaws seems spongy or slow, it may be a result of air in the clamp hoses. Normally there is no need to worry about bleeding the clamp lines because the unit is shipped fully tested. However, should the vibro sit for a long period of time, if a new attachment is being installed or if a damaged clamp hose has been replaced, then the system may require bleeding to remove unwanted air in the system. To bleed the clamp system, follow these steps:

- 1.) Shut excavator OFF.
- 2.) Make sure the clamp lines are coupled to the sequence manifold.
- 3.) Start the excavator engine and run at 1500 rpm. Give the engine time to warm up.
- 4.) Loosen the clamp lines at the hydraulic cylinder by backing the fittings off just a little.
- 5.) Push the joy stick of the excavator to the "FORWARD" position for the vibro and wait for oil to flow from the fittings. WATCH FOR AIR BUBBLES. When air bubbles have stopped then quickly re-tighten the fittings.
- 6.) Repeat the same procedure for "OPEN" side. To OPEN the jaws pull the joy stick in the RETURN direction
- 7.) Operate the jaws. If they are still a bit spongy then repeat bleeding steps once more.

**WARNING: DO NOT BLEED SYSTEM AT FULL ENGINE THROTTLE BECAUSE TOO MUCH OIL WILL FLOW FROM THE HOSES AND COULD CAUSE INJURY.**

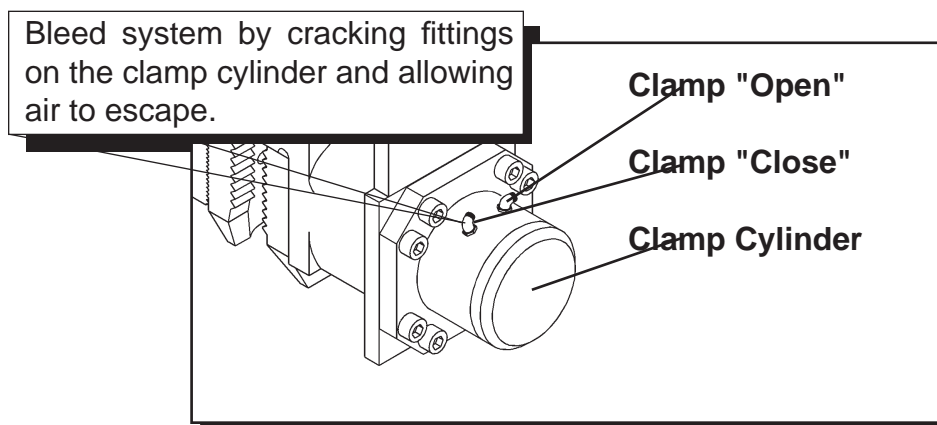

Figure 4-J. Bleeding Clamp Attachment



# **OPERATION / MAINTENANCE MANUAL**

MODEL 50E VIBRATORY HAMMER

7032 SOUTH 196th - KENT, WA 98032 - (253) 872-0141 / FAX (253) 872-8710

## **IV. PREPARATION AND OPERATION (Continued...)**

### **IV-6. Precautions and Rules for Operation**

The following is a list of precautions, suggestions and rules that are intended to help promote the safe and productive use of the APE Model 50E Vibratory Hammer.

- 1.) Follow the Daily Maintenance Required Prior to Operation, [Section V-1.] [page 5-1].
- 2.) Read and follow the Safety Precautions, [page v].
- 3.) Follow the start-up procedures listed in the manual for the power unit being used.
- 4.) Start with piles in good condition.
- 5.) Put all teeth in pile.
- 6.) Drive in steps eight feet or less.
- 7.) Keep sheets plumb.
- 8.) Come up to speed before doing work.
- 9.) No dancing. Avoid de-intensification.
- 10.) Drive past obstacles and then go back.
- 11.) Backhoe on site to remove obstacles.
- 12.) Lead with the ball.
- 13.) Probe the pile if it appears stuck.
- 14.) Keep piles plumb or down the road you go.
- 15.) Never rush the sheet pile foreman.
- 16.) Slow and plumb and the job will get done.
- 17.) Melted inner locks - piles out of plumb.
- 18.) Never stand under pile hammers.
- 19.) Low clamp pressure means jaw failures.
- 20.) Wait for vibro to get to full speed then pull.
- 21.) Don't over excavate - lower the ring.
- 22.) Look at the jaws during driving.
- 23.) Beware of cracked or broken sheets.
- 24.) In sandy soils drive faster.
- 25.) In clay amplitude is everything.
- 26.) Low drive pressure means easy work.
- 27.) High pressure means friction on piles.
- 28.) Over 4500 psi means get a bigger hammer.
- 29.) No amplitude means get a bigger hammer.
- 30.) Caissons need heavy wall to avoid flex.
- 31.) Check clamp bolts each morning.
- 32.) Read the manual - know your machine.
- 33.) Attach whip line to pile when pulling.
- 34.) Know your line pull.
- 35.) Extract straight - look at boom and cable.
- 36.) Give boom stops some room.
- 37.) Stalled engine means dirty fuel filters.



# **OPERATION / MAINTENANCE MANUAL**

MODEL 50E VIBRATORY HAMMER

7032 SOUTH 196th - KENT, WA 98032 - (253) 872-0141 / FAX (253) 872-8710

## **IV. IV. PREPARATION AND OPERATION (Continued...)**

### **IV-7. Sequence Valve Settings Prior to Operation**

1. Start with the Sequence Valve (SQJB-LAN) screwed all the way out. Turn the adjustment screw in two full turns. With engine at fast idle Slowly pull back on stick control to vibrate. Watch gauge that is connected to port "G2" to see as what pressure the vibro begins to turn. Adjust Sequence Valve inward or outward until the vibro begins to turn at when gauge port "G2" reads 1800 psi. Lock adjustment.
2. This circuit is rated for 105 gpm maximum at 5000 psi. Speed of the vibro is solely dependent on excavator pump flow and engine RPM.
3. Minimum clamp pressure = 1800 psi  
Maximum clamp pressure = 5000 psi  
(Customer setting)
4. Maximum system pressure determined by the excavator load sense and or relief valve settings.

WARNING: Vibro can be over speeded with excavator RPM and pump flows.

### **IV-8. Shut-down Procedures**

The following procedures explain what to do with the power unit to correctly shut down the APE Model 50E Vibratory Hammer.

- 1.) Stop the vibrator. (Refer to the power unit operating manual .)
- 2.) Allow the diesel engine to run for five minutes at 1000 engine rpms.
- 3.) Reduce engine speed to low idle for about 60 seconds.
- 4.) Shut engine off by turning off the main power switch.

**WARNING: Do not shut the power unit engine down while the vibrator is clamped onto a pile. The clamp check valve will slowly bleed off if there is any leakage in the hose lines or worn clamp seals in the cylinder that moves the jaw open or closed.**