

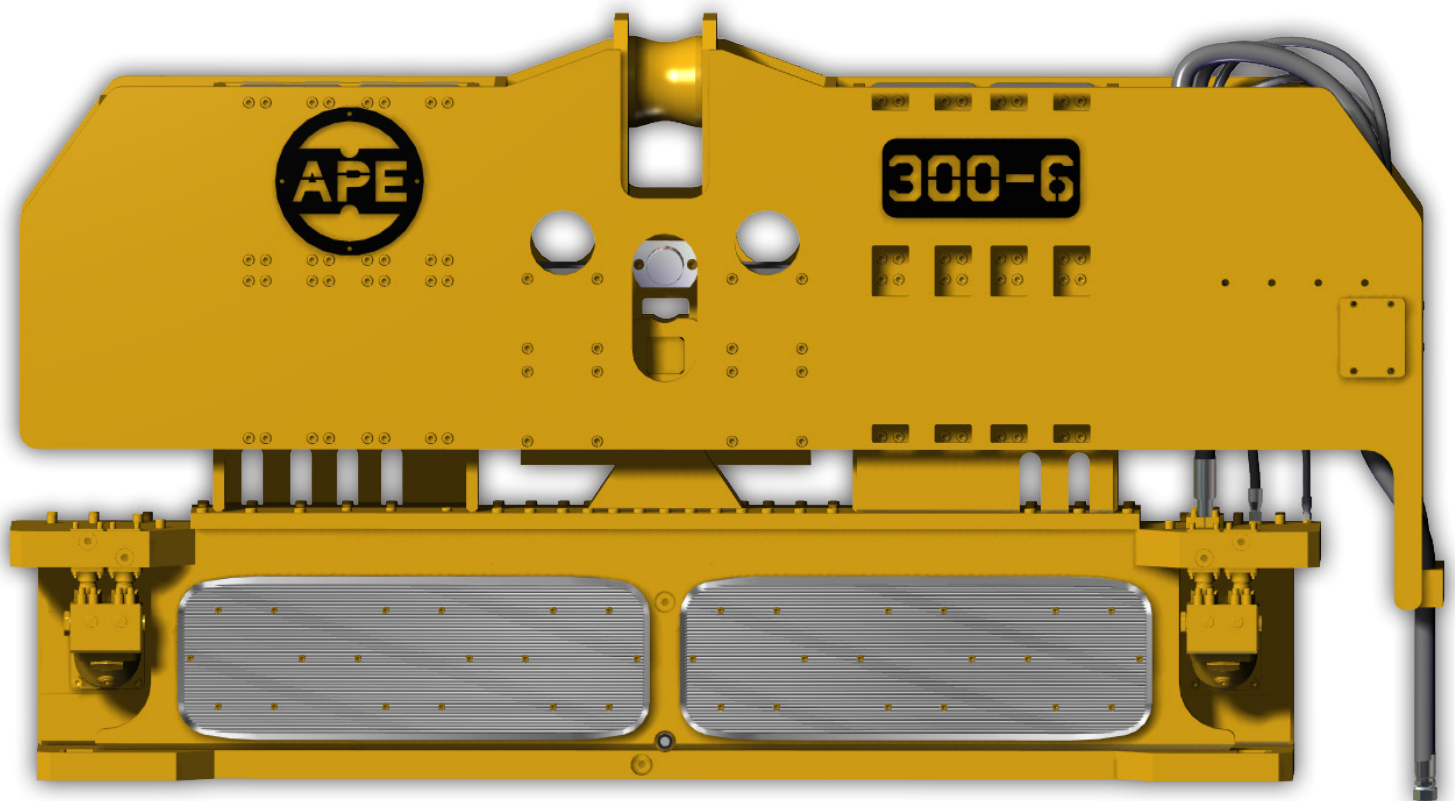

# APE VIBRO OWNER'S MANUAL

DEEP FOUNDATION  
SOLUTIONS



**800-248-8498**  
[WWW.AMERICANPILEDRIVING.COM](http://WWW.AMERICANPILEDRIVING.COM)

**MODEL 300-6 VIBRO**

Copyright © 2020 American Piledriving Equipment Inc. All Rights Reserved

**Copyright © 2020 American Piledriving Equipment Inc.**

*All rights reserved, No part of this publication may be reproduced, distributed, or transmitted in any form of by any means, including photocopying, recording, or other electronic or mechanical methods, without prior written permission of the publisher. For permission requests, write to the publisher, addressed “**Attention: American Piledriving Equipment Manual Division**” at the address below.*

AMERICAN PILEDIVING EQUIPMENT, INC.

7032 S. 196th Street

Kent, Washington 98032

Office: 253-872-0141

Toll Free: 800-248-8498

Fax: 253-872-8710

[APE\\_Manuals@americanpiledriving.com](mailto:APE_Manuals@americanpiledriving.com)

---

# Quick Reference Guide

---

This Quick Reference Guide will assist you in finding the information you're looking for.

**GENERAL INFORMATION**

**MAINTENANCE & TROUBLESHOOTING**

**REPLACEMENT PARTS**

**REFERENCE / NOTES**

A Table of Contents is included after the Foreword.

Description:

MODEL 300-6 VIBRO

*Page 1*





# WARRANTY INFORMATION



American Piledriving Equipment, Inc. (APE) warrants new products sold by it to be free from defects in material or workmanship for a period of one (1) years after the date of delivery to the first user and subject to the following conditions:

- APE's obligation and liability under this WARRANTY is expressly limited to repairing or replacing, at APE's option, any parts which appear to APE upon inspection to have been defective in material or workmanship. Such parts shall be provided at no cost to the user, at the business establishment of APE or the authorized APE distributor of the product during regular working hours.
- This WARRANTY shall not apply to component parts or accessories of products not manufactured by APE, and which carry the warranty of the manufacturer thereof, or to normal maintenance (such as engine tune-up) or normal maintenance parts (such as filters).
- Replacement or repair parts installed in the product covered by this WARRANTY are warranted only for the remainder of the warranty as if such parts were original components of said product.
- APE makes no other warranty, expressed or implied, and makes no warranty of merchantability of fitness for any particular purpose.
- APE's obligations under this WARRANTY shall not include any transportation charges, costs of installation, duty, taxes or any other charges whatsoever, or any liability for direct, indirect, incidental or consequential damage or delay.
- If requested by APE, products or parts for which a warranty claim is made are to be returned, transportation prepaid, to APE.

OIL MUST MEET ISO CLEANLINESS CODE 17/15/11.  
OIL THAT DOES NOT MEET CLEANLINESS CODE WILL  
**VOID** THE WARRANTY

ANY IMPROPER USE, INCLUDING OPERATION AFTER DISCOVERY OF DEFECTIVE OR WORN PARTS, OPERATION BEYOND RATED CAPACITY, SUBSTITUTION OF ANY PARTS WHATSOEVER, USE OF PARTS NOT APPROVED BY APE OR ANY ALTERATION OR REPAIR BY OTHERS IN SUCH A MANNER AS, IN APE'S JUDGMENT, AFFECTS THE PRODUCT MATERIALLY AND ADVERSELY, SHALL  
**VOID** THIS WARRANTY.

ANY TYPE OF WELDING ON APE'S EQUIPMENT WILL  
**VOID** THE WARRANTY UNLESS AUTHORIZED IN WRITING BY APE

NO EMPLOYEE AUTHORIZED TO CHANGE THIS WARRANTY IN ANY WAY OR GRANT ANY OTHER WARRANTY UNLESS SUCH CHANGE IS MADE IN WRITING AND SIGNED BY AN OFFICER OF APE, INC.





(These precautions must be followed at all times to ensure personal and equipment safety.)



DANGER indicates a hazardous situation which, if not avoided, will result in death or serious injury.



WARNING indicates a hazardous situation which, if not avoided, could result in death or serious injury.



CAUTION indicates a hazardous situation where injury could occur but is unlikely to be serious or lead to death.



NOTICE indicates information that may help or guide you in the operation or service of the equipment.

## DISCLAIMER

This unit was tested and flushed before leaving our facility. In order to help provide years of trouble free usage, please review the following documentation and make sure to clean and flush the field piping before connecting it to the power unit.

Refer to schematic diagrams and the BOM (Bill of Materials) for component part specifications and recommended spare parts.

When calling APE (American Piledriving Equipment), always inform them of the supplied serial # in order to obtain quicker service.



**READ THIS MANUAL THOROUGHLY BEFORE OPERATING AND / OR WORKING ON THE EQUIPMENT.**

1. Read and follow any safety instructions in the Excavator operators manual.
2. Only well-trained and experienced personnel should operate or maintain this equipment.
3. Do **NOT** adjust, lubricate or repair the unit when it is in operation or lifted above ground level.
4. Do **NOT** remove, paint over and/or cover warning or safety labels. If labels become damaged or unreadable, replace immediately.
5. All personnel should wear approved safety clothing, including **HARD HATS**, **SAFETY SHOES**, **SAFETY GLASSES** and **HEARING PROTECTION** when near this equipment.
6. Do **NOT** stand close to this equipment when it is in operation. Dirt and parts may fall. **NEVER** stand under operating or elevated equipment. Keep your eyes on the hammer while it is in operation.
7. When maintaining and/or repairing the equipment, **NEVER** substitute parts not supplied or approved in writing by APE.



**Do NOT WELD OR FLAME CUT ON THIS EQUIPMENT.**

8. Do **NOT** use or store flammable liquids on or near the engine.
9. Ensure that all lifting equipment, including cranes, wire rope, slings, hooks, shackles, etc., are properly sized for the worst case loads anticipated during operations.
10. If there are any questions about the weights, specifications or performance of the unit, contact APE before handling and/or operating the equipment.
11. Check wire rope clips for tightness and wire ropes for wear daily.



**WHEN OPERATING IN AN ENCLOSED AREA, EXHAUST FUMES SHOULD BE PIPED OUTSIDE.**

**CONTINUED BREATHING OF EXHAUST FUMES MAY PROVE FATAL.**

(These precautions must be followed at all times to ensure personal and equipment safety.)

12. Ensure that ground vibrations will not damage or collapse adjacent structures or excavations.
13. Remove all tools, parts and electrical cords before starting the unit.
14. Do **NOT** smoke or use an open flame while servicing batteries. Batteries generate explosive gas during charging. Keep the area ventilated.
15. When filling the fuel tank do **NOT** smoke or use an open flame in the vicinity.
16. If abnormal equipment operation is observed, stop use immediately and correct the problem.
17. Store oily rags in approved containers and away from the engine exhaust system.
18. Do **NOT** adjust the hydraulic pressures higher or lower than those specified in this manual.
19. Do **NOT** operate this equipment with hydraulic hoses that are damaged or 'kinked'. Replace damaged hoses immediately.
20. Do **NOT** support hydraulic hoses with wire rope.
21. Do **NOT** allow hydraulic hoses to snag during movement of the unit.
22. Do **NOT** pull on and/or attempt to move equipment with the hydraulic hoses.
23. Do **NOT** attempt to locate hydraulic leaks with your hands. High-pressure leaks can penetrate skin and cause severe damage, blood poisoning, and/or infection.
24. Do **NOT** attempt to repair leaks while the equipment is in operation.
25. Do **NOT** attempt to tighten and/or loosen fittings and/or hoses when the machine is in operation.
26. When moving and/or transporting this equipment, insure that the vehicle or vessel is of sufficient capacity to handle the load. Make sure that the equipment is properly tied down.
27. When moving this equipment be sure that the QD Dust Caps are tight and that the cap safety cables are in place. Be sure that all equipment parts are tight and properly secured before shipment. Unsecured parts may vibrate loose and fall causing injury and/or property damage.
28. Rounded and/or damaged bolt heads and nuts should be replaced. Proper torque values are necessary to prevent parts on this equipment, leads, and crane booms from loosening and falling. Refer to the torque chart in this manual.
29. Keep limbs and tools clear of the clamp jaws.

## NOTICE

- A PROPERLY MAINTAINED FIRE EXTINGUISHER, SUITABLE FOR OIL FIRES, MUST BE KEPT IN THE IMMEDIATE VICINITY OF OPERATIONS.**
30. Do **NOT** allow clothing, hoses, ropes, etc., to become entangled in moving components, including the clamp and suppressor.
  31. Keep excavator, piles, vibrator, wire rope, and other equipment at least 15 feet (5 meters) from electrical power lines, transformers, and other electrical equipment, or at such distance as required by applicable safety codes.
  32. Never disconnect the excavator and vibrator while the vibrator is on pile. Loss of hydraulic pressure will cause vibrator to fall. Lay vibrator down when not in use.
  33. When extracting piles always attach a safety line between the pile and the excavator.
  34. When extracting piles, check excavator load/radius tables to be sure capacity is adequate for maximum allowable extraction pull.
  35. When extracting or driving piles always be sure that the excavator bucket pivot pin is aligned with the centerline of the pile. Do not side load the vibrator. Vibrator damage will result.
  36. When extracting piles, do not exceed the capacity of the vibrator suppressor.
  37. Check vibrator suppressor for broken or damaged elastomers daily. Do not operator vibrator with damaged elastomers.
  38. Always start both driving and extraction of piles in an unloaded condition.
  39. Do **NOT** run the vibrator without clamp jaws closed.
  40. Guide the vibrator with a tag line when possible.



**DO NOT ATTEMPT TO LIFT OR WALK WITH PILES EXCEEDING 10 TONS WEIGHT.**



**KEEP HANDS, FEET, AND/OR TOOLS WELL CLEAR OF ALL CLAMP JAWS AND SUPPRESSOR ELASTOMERS.**

---

(These precautions must be followed at all times to ensure personal and equipment safety.)

---

## NOTICE

**CHECK THE ENTIRE UNIT PRIOR TO AND DURING SET-UP  
EACH DAY OR AT THE BEGINNING OF EACH SHIFT**

Prior to starting the unit or at the beginning of each shift, check the following:

- Visually inspect all bolts, nuts and screws.
- Visually inspect all suppressor elastomers.
- Tighten bolts holding gripping jaws to the hydraulic clamp.
- Check the oil level in the vibration case and add oil if required. The oil level should be in the middle of the sight glass. Change oil if it is milky or contaminated.
- \* **DO NOT OVERFILL.**
- Visually inspect all hydraulic fittings for leaks. If a leak is found or suspected, shutdown the power unit. If a fitting appears to be damaged replace it with a new fitting.
- Check the hydraulic motor and hydraulic manifold for leaks.

## NOTICE

**IT IS ABSOLUTELY IMPERATIVE THAT NO DIRT OR OTHER IMPURITIES BE PERMITTED  
TO CONTAMINATE THE HYDRAULIC FLUID. ANY CONTAMINATION WILL DRASTICALLY  
SHORTEN THE LIFE OF THE HIGH-PRESSURE HYDRAULIC SYSTEM.**

**VIBRATION LOOSENS BOLTS. CHECK THEM THOROUGHLY.**



---

# FOREWORD

---

This manual covers the **APE 300-6 Vibro** installation, maintenance and use.

The data provided in this manual gives the necessary information to operate and maintain APE equipment. The listed procedures are to be performed by qualified personnel who have an understanding of the equipment and who follow all safety precautions.

All information given in this manual is current and valid according to the information available at the time of publication. American Piledriving Equipment, Inc. reserves the rights to implement changes without prior notice.

## **Using this manual:**

- Refer to the Table of Contents for the page location of applicable sections.
- All weights and measurements are in English and Metric units.
- Any revisions to this manual will appear on the Revision Record page at the back of this manual.
- Please visit [www.americanpiledriving.com](http://www.americanpiledriving.com) for product data sheets and manual.

## **COMMON ABBREVIATIONS AND TERMS**

<b>APE</b>	: American Piledriving Equipment	<b>cm</b>	: Centimeters
<b>Vibro</b>	: Vibrator	<b>m</b>	: Meters
<b>QD</b>	: Quick Disconnect	<b>kg</b>	: Kilogram
<b>HCLW</b>	: High Collar Lock Washer	<b>kN</b>	: Kilo-newton
<b>SHCS</b>	: Socket Head Cap Screw	<b>Rpm</b>	: Revolutions per Minute
<b>BOM</b>	: Bill of Materials	<b>Vpm</b>	: Vibrations per Minute
<b>P.O.</b>	: Pilot Operated	<b>cyl</b>	: Cylinder
<b>lbs</b>	: Pounds	<b>eng</b>	: Engine
<b>in</b>	: Inches	<b>Mtg</b>	: Mounting
<b>psi</b>	: pound per Square Inch	<b>Sol</b>	: Solenoid
<b>mm</b>	: Millimeters	<b>S/N</b>	: Serial Number

## **SERIAL NUMBER LOCATIONS**

Vibrator : Above and in between the eccentric covers on both sides of the machine.  
Power Unit: On both sides in front of reservoir near the top

# TABLE OF CONTENTS

WARRANTY INFORMATION	2	STORAGE	18
300-6 VIBRO SPECIFICATIONS	7	BLEEDING THE CLAMP CYLINDERS	19
TABLE OF CONTENTS	7	CHECKING BEARING	20
VIBRO & CLAMP CHECKLIST	8	REPLACEMENT PARTS	23
GENERAL INFORMATION	9	OUTER SUPPRESSOR ASSEMBLY	24
VIBRO OVERVIEW	11	GEARBOX SUBASSEMBLY	26
CONNECTING THE HYDRAULIC	13	REPLACEMENT PARTS	26
BLEEDING THE HYDRAULIC SYSTEM	14	REPLACEMENT PARTS	27
WARM UP PROCEDURE	14	BRAKE VALVE ASSEMBLY	28
OPERATING TEMPERATURES	14	REFERENCE / NOTES	30
SHUT DOWN PROCEDURE	15		
CHANGING FREQUENCY	15		
MAINTENANCE & TROUBLESHOOTING	16		
MAINTENANCE CHART	16		
SEVERE CONDITIONS	17		
OIL RECOMMENDATIONS	17		

## 300-6 VIBRO SPECIFICATIONS

### DIMENSIONS

Overall Length	155 in	(394 cm)
Overall Width	22.25 in	(56.5 cm)
Overall Height	81.62 in	(207 cm)
Overall Height w/ Clamp	117 in	(296 cm)
Throat Width	35 in	(89 cm)

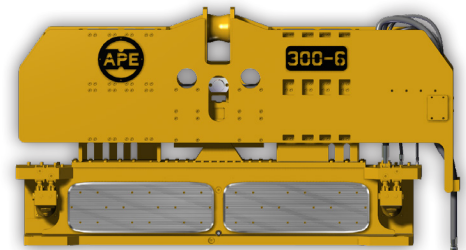

### SPECIFICATIONS EQUIPPED WITH A 800 POWER UNIT

Eccentric Moment	8000 in-lbs	(92.17 kg-m)
Frequency	0 - 1650 VPM	
Drive Force	309 tons	(2,751 kN)
Max Line Pull	185 tons	(1,646 kN)
Bare Hammer weight	21,200 lbs	(9,616 kg)



### SPECIFICATIONS EQUIPPED WITH A 950 POWER UNIT

Eccentric Moment	8000 in-lbs	(92.17 kg-m)
Frequency	0 - 1850 VPM	
Drive Force	389 tons	(3,458 kN)
Max Line Pull	185 tons	(1,646 kN)
Bare Hammer weight	21,200 lbs	(9,616 kg)





# VIBRO & CLAMP CHECKLIST

## IMPORTANT NOTICE!

**WARNING:** When filling gearbox oil, never use 90W gear oil or vibro will overheat. If you cannot read the level then do not operate the machine. Remove the sight glass (See Image J for location reference) Spray WD40 to clean the glass, then reinstall the sight glass using Teflon tape. Do not overfill or the vibro will overheat. If gearbox sight glass level increases, it can indicate there is a bad motor shaft seal. Results are hydraulic oil entering the gearbox.

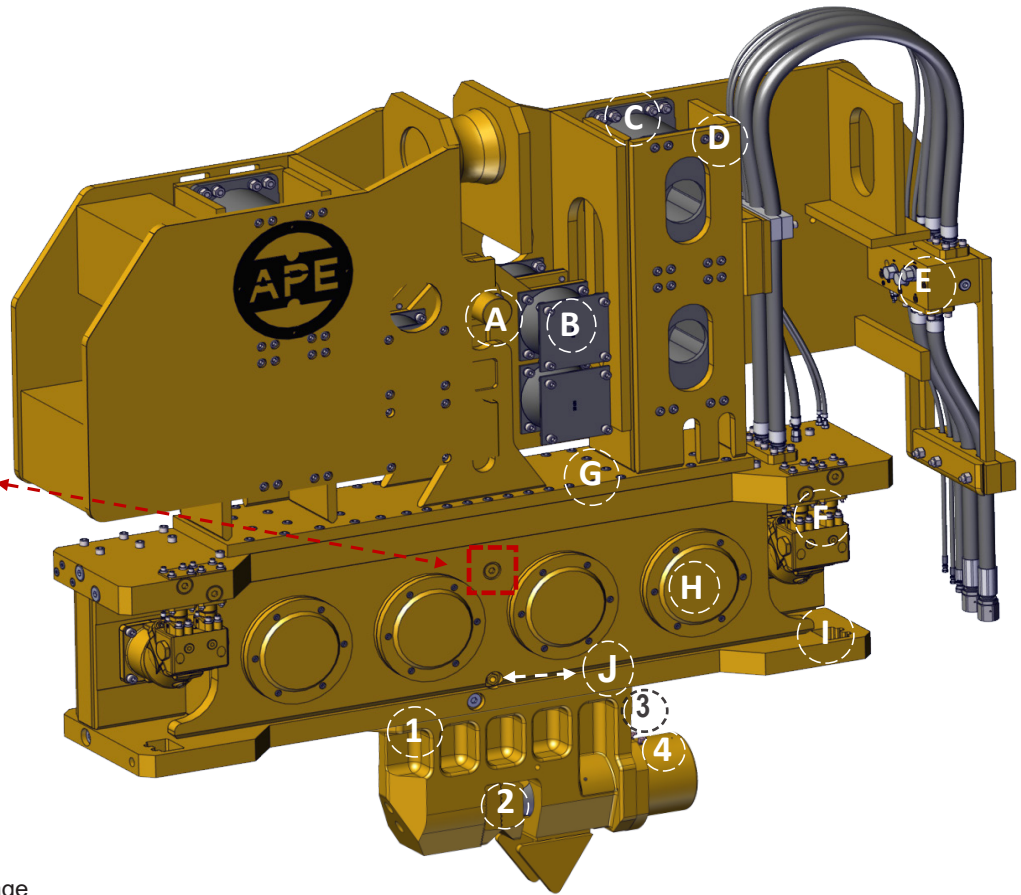

Model Shown. 300-4 Vibro

## VIBRO

- A) Inspect safety pin for damage
- B) Inspect small elastomers for cracks
- C) Inspect large elastomers for cracks
- D) Inspect all bolts on elastomers
- E) Inspect pop-off safety valve & manifold for leaks
- F) Inspect motor couplers for leaks
- G) Inspect suppressor mounting bolts
- H) Inspect bearing covers for damage
- I) Inspect clamp line hose bracket
- J) Checked oil level in gearbox

(See image "J" below for reference)

- Line pull safety sticker is visible
- Inspect all welds for cracks
- Inspect breather check valve on motor bearing cover. Remove any paint that could block breather
- Inspect shackle pin cotter key & nut "Most models do not use a shackle"
- Inspect hoses for wear, "If wires are exposed in hoses, replace immediately"

## CLAMP

1. Inspect clamp mounting bolts for tightness
2. Inspect both movable and fixed jaw teeth
3. Inspect clamp lines and fittings leading to the clamp cylinder.
4. Remove any air from the clamp lines by cracking them open at the clamp cylinder while the power unit engine is at an idle speed

### Reference "J"

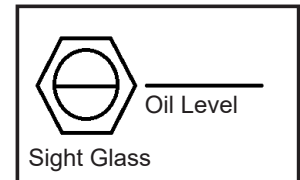

**NOTE:** When mounting a new clamp, check machined surfaces on the bottom of the hammer and on top of the clamp with a straight edge. Clean each mounting hole with a bottom tap and WD40. Make sure the surface is clean and flat. Torque down using a hydraulic torque multiplier. Do not drive piles if any clamp mounting bolt are missing. If the clamp attachment falls off, it is due to bolts not being properly torqued.

## VIBRATOR CHECKLIST PRIOR TO SHIPMENT

\* Items checked with an asterisk should be checked regularly, but not every time the unit is serviced

### Checking the suppressor

- Removed all wire rope for insurance reasons
- Checked Shackle pin cotter key and nut
- Checked large elastomers for signs of cracks
- Checked small elastomers for signs of cracks
- Checked all bolts on elastomers
- Removed and checked anti-cavitation valve\*
- Inspected pop off safety check valve
- Checked line pull pin and multi-stage pin
- Inspected all suppressor mounting bolts
- Inspected entire suppressor for weld cracks
- Installed safety line pull sticker
- Inspected all hoses and fittings on suppressor
- Inspected all fittings on rifle board top plate
- Checked suppressor loop hoses for wear

### Vibro gearbox

- Checked gearbox oil level
- Flushed gearbox with flushing system
- Changed gearbox oil
- Removed and cleaned gearbox oil site gage
- Removed and cleaned magnetic drain plug
- Checked/replaced damaged bearing cover bolts
- Removed, cleaned, and replaced breather valve
- Checked motor bearing cover bolts
- Checked bottom of gearbox- all mounting holes
- Checked entire bottom clamp mounting surface
- Checked hydraulic motor mounting bolts
- Checked motor couplers for leaks
- Checked motor coupler bolts
- Inspected entire gearbox for signs of cracks
- Removed any welding attached by pile crew
- Inspected main bearings visually for wear\*
- Inspected motor bearings visually for wear\*

### Clamp attachment: sheet wood caisson other

- Measured jaw opening width for pile
- Checked with contractor to confirm pile thickness
- I am sure the jaws will open wide enough
- Checked to see if mounting bolts were tight
- Replaced worn jaws, inspected teeth and bolts
- Checked fixed jaw bolts
- Checked vertical jaw pin and put spare in box
- Checked 90 degree hyd fittings on clamps
- Inspected clamp casting for cracks
- Serial number stamped and welded with SS rod
- Greased slide
- Inspected clamp hoses, replace if necessary
- Removed air from lines of clamp cylinder
- Stroked cylinder back and forth for visual check
- Put spare back up jaws in power unit tool box
- Put extra clamp bolts in tool box

### Vibro test

- Checked and cleaned quick disconnects
- Checked to make sure caps and plugs are there
- Checked all o-rings on QD's
- Put spare o-ring kit in tool box of power unit
- Closed jaws and checked hoses for leaks
- Checked clamp pressure with hoses attached
- Checked pendant light to make sure it works

### Test Data:

Free hanging drive pressure: \_\_\_\_\_

Cycles per minute: \_\_\_\_\_

Temperature of hydraulic oil at time of test: \_\_\_\_\_

### Tips for the APE service technicians and pile crew:

Do not free hang test the vibro with the jaws open because the Move-able jaw could break from vibration.

Close the jaws!

Before removing clamp quick disconnects, please open the jaws.

This will take the hydraulic pressure off the fittings so that you can remove them by hand.

Please clean the control panel and spray some armor all on it. Prior to the vibro going out on rent it must look like new condition. If the paint appears bad then paint it. If the paint surface is bad then have it sand blasted. Do not allow the hammer to go out looking bad. Any bad hoses should be replaced. The most important thing is the condition of the jaws and the hoses. Both should be new or in new condition. If this unit is going to operate in cold weather then please make sure the proper oils have been used. In cold weather operations we must use a softer o-ring to handle the colder temperatures. Spare parts that should be with the vibro power unit:

- Two spare 90 degree fittings for the clamp cylinder
- One sight glass with teflon tape already installed and boxed
- One socket wrench for removing and replacing sight glass
- One manual with copy of this check out sheet
- Two extra clamp lines with plugs on both ends
- Two extra caps and two extra plugs for the clamp cylinder
- One spare set of jaws and two jaw pins and fixed jaw bolts
- Two extra clamp mounting bolts.



# GENERAL INFORMATION

## SAFETY / WARNING LABELS

GENERAL INFORMATION



This plate contains numbers key to identifying the unit. This information is important when contacting APE for replacement parts or repair instructions.



Do not use the vibro as a lifting device. The clamp may lose pressure and drop the load, causing property damage, serious injury, or death.



Do not weld on or around the vibro unless authorized in writing by APE. Doing so will void all warranties and may cause damage to the vibro.

## VIBRO OVERVIEW

The model 300-6 vibro is a high frequency vibratory pile driver / extractor designed to drive and extract sheet piles, pipe, timber piles and concrete piles, caisson pipe and H, I and wide-flange beams.

The Model 300-6 operates in a frequency range of 1250 to 1850 vibrations per minute to provide maximum pile penetration rates in a wide variety of soils. The unit has an eccentric moment of 8,000 inch-pounds.

The vibratory driver unit consists of two major components

The vibration case which consists six eccentric weights which rotate in a vertical plane to create vibration. The eccentric weights are driven by a hydraulic motors mounted on the vibration case. The motors and six eccentrics are all gear connected to maintain a proper synchronization.

The eccentric and motor shafts are mounted in heavy-duty cylindrical roller bearings. Lubrication is provided by a splash system activated by the rotating eccentrics and gears.

A suppressor assembly is mounted to the top of the vibration case, to isolate vibration from the crane an permit pile extraction. A heavy outer suppressor housing is connected to the vibration case by ten rubber elastomer's. The maximum line pull during extraction is 185 tons.

A hydraulic clamp, bolted to the bottom of the vibration case, transmits to the piling. The hydraulic clamp contains two gripping jaws; one fixed and one movable. A large hydraulic cylinder operates the movable jaw with 125 tons (1,112kN) of force to grip the pile. Clamping and un-clamping occurs in a few seconds.

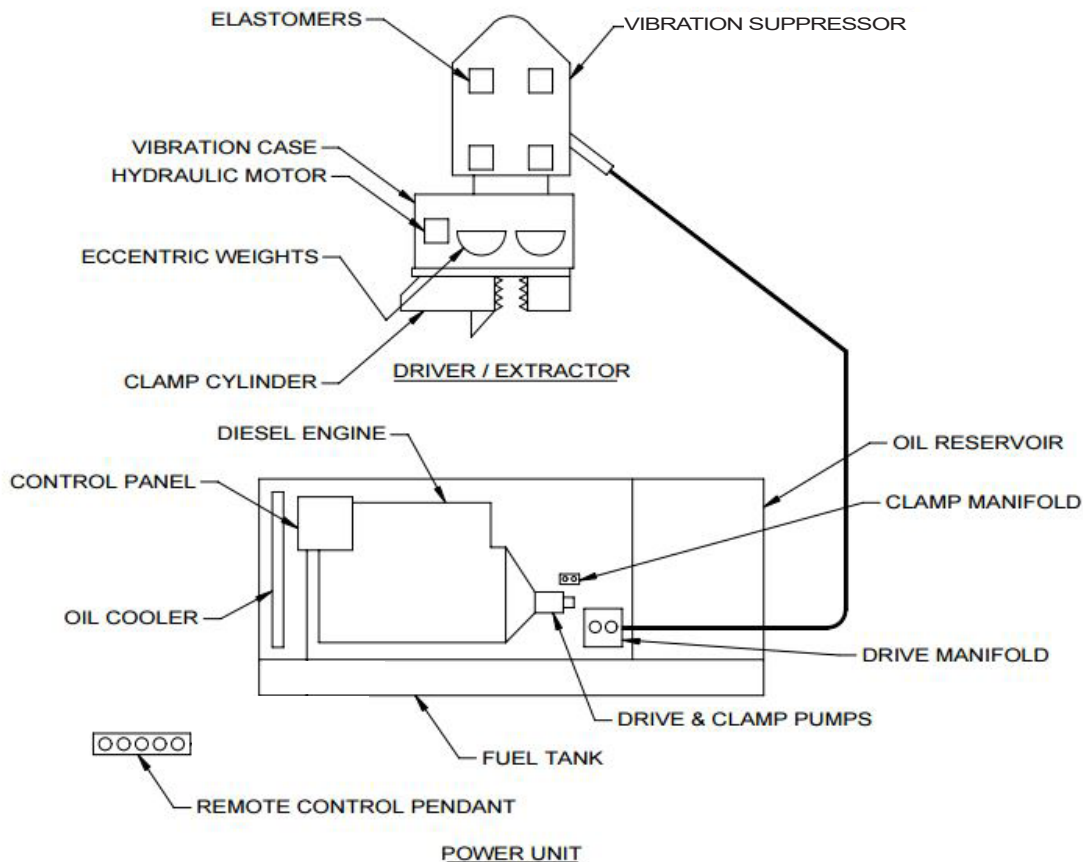

# GENERAL INFORMATION

## VIBRO OVERVIEW

GENERAL INFORMATION

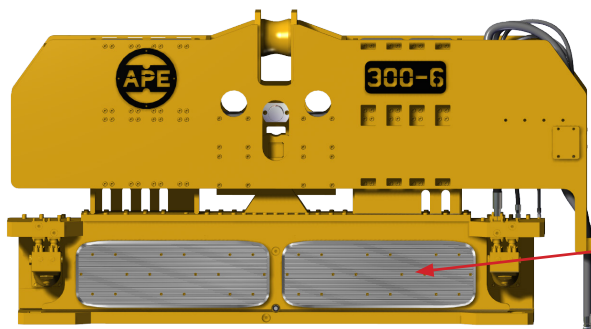
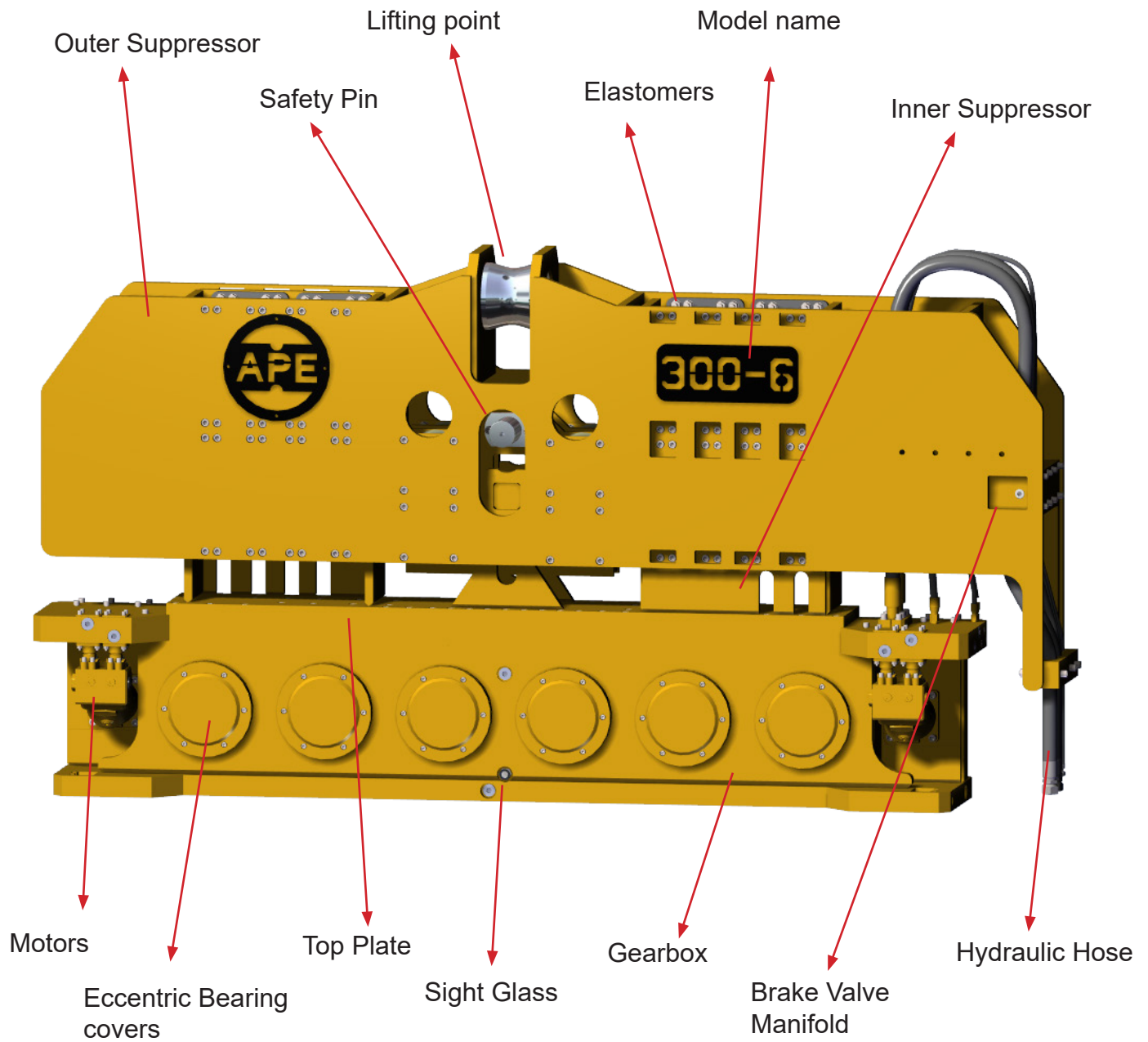

# GENERAL INFORMATION

## CONNECTING THE HYDRAULIC HOSES

Before connecting the hoses to the power unit ensure that the power unit is powered off. The quick disconnect couplers must be clean and free on any dirt or contaminants. Clean the quick disconnect couplers with brake wash if necessary.

The vibrator is usually shipped with the hoses attached to the vibrator. If the hoses have been shipped separately, they must be connected as shown.

The vibrator is usually shipped with the hydraulic clamp and hoses attached. If the clamp has been shipped separately, the two hoses connecting the clamp to the vibrator must be connected as shown in the figure to the right.

For caisson clamps four hoses must be connected. The two o-ring - jic fittings on the terminal manifold must be removed and replaced by two tees. This allows the four hoses to run both sides of the vibrator and operate the caisson clamps. The terminal manifold is stamped "O" Open and "C" Close for the clamp.

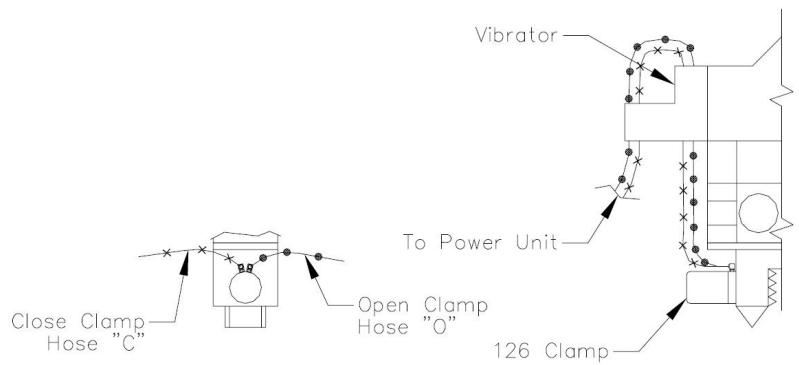
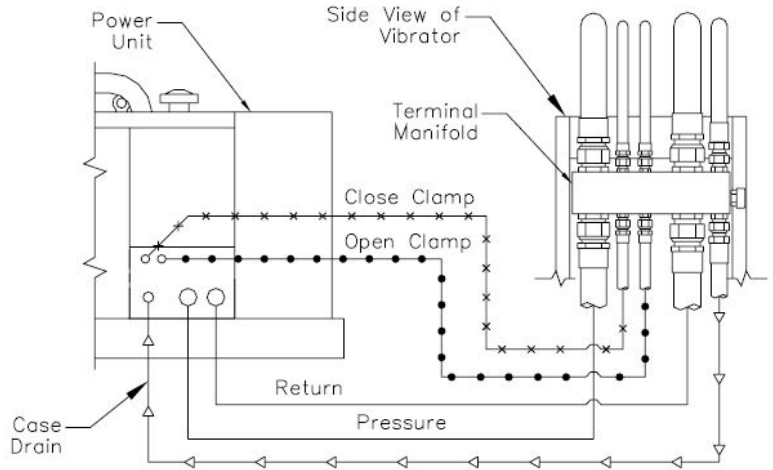

GENERAL INFORMATION

## Attention!

Connecting the hoses is one of the most critical aspects of commissioning an APE equipment. Take extreme care to keep these connections absolutely clean. This procedure is one of the most common ways for foreign particles to be introduced into a hydraulic system.

**New hydraulic fluid is NOT clean oil!**

**Oil must meet ISO cleanliness code 17/15/11**

## Attention!

Pressurizing the system while there is air entrained in the fluid may cause damage to the components.

Let the system run at idle for an **additional 10 minutes** to allow the air to rise into the airspace of the hydraulic reservoir.



## GENERAL INFORMATION

### BLEEDING THE HYDRAULIC SYSTEM

#### Bleeding Clamp Hoses

1. When the vibrator and hydraulic clamp are shipped with all hoses attached (between vibrator and clamp and five main hoses connected to the vibrator), the hoses are usually full of oil and may be used immediately. However if any of the clamp hoses are connected at the job site or if air is present in hoses they must be bled prior to operation
2. Start and warm up the hydraulic power unit.
3. With the power unit warmed-up and running at 1500 RPM loosen the clamp close hose at the hydraulic clamp. Turn the clamp switch on the remote control pendant to close. Wait until only oil flows from the connection at the hydraulic clamp. When oil flows without air tighten the connection.
4. Repeat step 3 with the clamp open line.
5. After the line has been bled, alternately turn the clamp switch to close and open to insure that the clamp is working properly. It may be necessary to bleed the line more than once.

#### Filling Vibrator Pressure Hoses

1. Start and warm up the hydraulic power unit.
2. With the engine warmed up and running at 1000RPM turn and hold the vibrator switch in reverse. The hoses will fill in approximately 5 minutes.

**Caution: If vibration begins in the vibrator, stop immediately and recheck hose connections.**

### WARM UP PROCEDURE

Before operation it is necessary to bring the power units hydraulic oil to a working temperature of 80°F. To start and warm up the power unit follow the steps below.

1. On the main control panel turn main power switch to the on position.
2. Press and hold engine start/stop button until engine in running. This should only take a few seconds.
3. Idle power unit in drive until oil temp is above 80°F before doing hard work. Failing to do so may cause seal failures, leaks and excessive pressures through the hydraulic system.

### OPERATING TEMPERATURES

The Operating Temperature references the internal temperature of the motor. Take into consideration the following requirements:

- 21°C (70°F) – Operate the Vibro at reduced speed while below this temperature
- 27°C (80°F) – Ideal working temperature.
- 70°C (158°F) – Avoid going over this Operating Temperature for improved service life
- 85°C (185°F) – Highest permissible intermittent Operating Temperature
- -35°C (-31°F) – Lowest permissible Operating Temperature
- 60°C (140°F) – Temperature difference between the motor and the hydraulic fluid

The Operating Temperature may be measured from the hydraulic fluid returning from the motor. Case drain fluid temperature will also have an effect.

### SHUT DOWN PROCEDURE

1. Stop the vibrator.
2. Allow the hydraulic power unit to run for five minutes at 1200 RPM
3. Reduce speed to low idle for approximately 30 second.
4. Stop the engine by pressing the engine start/ stop button

***Caution: If the hydraulic power unit engine is shut down while the vibrator is clamped to a pile, the clamp check valve will keep the vibrator clamped to the pile. However, system leakage could result in a loss of clamp pressure over time. It is NOT recommended to leave the vibrator clamped to a pile when the power unit is not running.***

### CHANGING FREQUENCY

In order to provide maximum flexibility in achieving optimum pile penetration and extraction rates, the frequency of the vibratory driver is adjustable.

The frequency can be varied from 900-1850 vibrations per minute by changing the engine speed. Engine speed is controlled with the governor on the main hydraulic control panel display, or on the remote control pendant.

# MAINTENANCE & TROUBLESHOOTING

## MAINTENANCE CHART

### NOTICE

In addition to keeping the unit in ideal condition, regular maintenance will help prevent unexpected machine downtime by finding minor issues before they can develop into serious or dangerous problems. Lubrication, inspection, and replacement of key parts are the major steps of this maintenance.

Lubrication is especially important and different components have their own schedules and lubrication types. Pay special attention to the lubrication steps noted in the chart above.

At each scheduled interval perform all previous checks which are due. During all steps be sure to:

- Thoroughly clean all lubrication fittings, caps, filler and level plugs along with their surrounding surfaces before servicing.
- Prevent dirt and other contaminants from entering with lubricants.

These service intervals are for normal operating conditions. Reduce the time by half when:

- The average temperature is above 80°F (26°C) or below -10°F (-23°C).
- Operating in a dusty or sandy area.
- Operating for more than 12 hours per day.

Environments that are humid and/or salty do not change the service intervals. However, during all procedures check the components for corrosion.

DAILY	WEEKLY	70 HOURS
<ul style="list-style-type: none"> <li>• Check operators report.</li> <li>• Check oil level in the gearbox and bring to correct level.</li> <li>• Inspect bolts, nuts, and screws for tightness.</li> <li>• Inspect elastomers for cracks.</li> <li>• Inspect fittings, hoses, and manifolds for leaks.</li> </ul>	<ul style="list-style-type: none"> <li>• Inspect hydraulic hoses and fittings for fraying and leaks. Replace any hoses with broken threads.</li> <li>• Bleed air from the hydraulic lines as described in the previous chapter.</li> <li>• Inspect gearbox magnetic drain plug for metal flakes. If flakes are found see Troubleshooting chart.</li> </ul>	<ul style="list-style-type: none"> <li>• Change gearbox oil.</li> <li>• Clean gearbox breather and pop-off valves.</li> <li>• Cycle oil into the hydraulic clamps as described later in this chapter.</li> </ul>
250 HOURS OR 6 MONTHS	1500 HOURS OR 1 YEAR	6000 HOURS OR 3 YEARS
<ul style="list-style-type: none"> <li>• Inspect eccentric bearings.</li> </ul>	<ul style="list-style-type: none"> <li>• Check torque on gearbox, suppressor, and clamp attachment mounting bolts.</li> <li>• Inspect hydraulic motors for leaks, wear, and proper operation.</li> <li>• Replace eccentric bearings.</li> </ul>	<ul style="list-style-type: none"> <li>• Replace eccentrics, elastomers, and hydraulic motors.</li> </ul>



# MAINTENANCE & TROUBLESHOOTING

## SEVERE CONDITIONS

The servicing intervals are specified on normal operation conditions. Operation under severe conditions require shorter service intervals.

- When the average outside temperature is above 80 F (26 C) or below -10 F (-23 C), reduce service time intervals by one-half.
- When operating in the presence of dust or sand, reduce service time intervals by one-half.
- When operating in air with high salt or moisture the service intervals do not need to be changed. However the unit should be inspected weekly to determine if additional servicing is required.

## VIBRATORY GEARBOX

The oil level is easily read through the sight glass located at the lower center of the vibratory gearbox on the motor side. Lubricating oil may be added when necessary, through the hole in the vibration case top plate after removing the 1" SAE O-ring plug. To drain the case, remove the 1" pipe plug at the end of the base plate. Tilt the case for complete drainage.

The preferred lubricating oil for APE vibro gearbox is high molly oil. The recommended oil by APE is Schaeffer 268.

The vibratory gearbox capacity is 17 Quarts Gallons (16 L).

*Sight-glass at ideal fill level.*

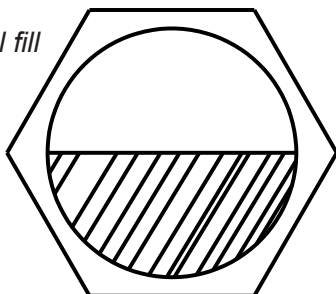

## OIL RECOMMENDATIONS

The gearbox lubricant installed by APE during manufacturing is Schaefer 268. If it is unavailable an alternative oil may be used when changing lubricants. Test and change the gearbox oil at smaller intervals if Schaefer 268 is not being used. The gearbox capacity is 1.5 gal, fill until you reach the half line mark on the sight glass.

### Second Preference Group

Mobil	SHC-634
Boron	Gearep 140
Chevron	Gear Comp. NL460
Citgo	Premium MP 85W-140
Citgo	Standard MP 85W-140
Gulf	Lub 85W-140
Phillips	MP 85W-140
Shell	Omala 460
Sun	Sunep 1110

### Third Preference Group

Amoco	Perma Gear EP140
Arco	Pennant NL 460
Conoco	EP 460
Exxon	Spartan EP 460
Phillips	AP 140
Texaco	Meropa 460
Union	MP 85W-140
Valvoline	Gear Lub 85W-140

### Hydraulic Oil Cleanliness

When adding or changing hydraulic fluid, APE uses only Biodegradable Envirolagic 146 hydraulic fluid. Consult your local oil supplier for recommendations on mixing hydraulic oils. See the warranty document at the beginning of this manual concerning fluid cleanliness, and Understanding ISO Codes at the rear of this manual.

**NOTICE**

**NEW HYDRAULIC FLUID IS NOT CLEAN OIL!  
OIL MUST MEET ISO CLEANLINESS CODE 17/15/11**

# MAINTENANCE & TROUBLESHOOTING

## STORAGE

During short-term storage of a Vibro, the following should be taken into consideration:

- Cover any pressure openings and open threaded holes with suitable caps.
- Protect the unpainted surfaces from dirt and moisture.
- The vibro should not be stored in an area with substances that have an aggressive corrosive nature; solvents, acids, alkalies and/or salts.

For long-term storage (over 9 months), the following additional actions are recommended:

- Damages to surface paint must be repaired before item is stored.
- Protect the unpainted surfaces with suitable anti-corrosion treatment such as CRC SP-350, CorrosionX corrosion inhibitor, or WD-40 Long Term Corrosion Inhibitor.
- Fill the power unit completely with hydraulic fluid.

If these instructions are followed to the letter, the vibro may be stored for approximately 2-years. However, as storage conditions do have a significant effect, all suggested time frames should be considered as guide values only.

## READING THE GEARBOX OIL LEVEL

The gearbox oil is a useful indicator of the health of the unit. Check the Troubleshooting chart if gearbox is overfilled, has discolored oil, or the oil contains metal flakes.

The oil level may be read from a sight-glass halfway up the vibro gearbox. Ideally the oil will fill midway up the sight-glass when the vibro is upright. If the level cannot be read remove the sight-glass and clean the window with ether.

## NOTICE

**IF YOU CANNOT READ THE GEARBOX SIGHT-GLASS DO NOT ASSUME IT IS FILLED. YOU MUST READ THE LEVEL TO RUN THE VIBRO.**

*Graphic of the sight-glass at ideal fill level.*

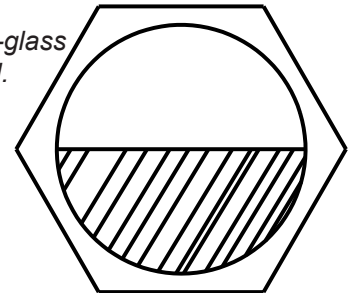

## CHANGING GEARBOX OIL

Gearbox oil can be added through a hole in the gearbox top plate. Remove the SAE plug to add oil.

To drain the gearbox, remove the pipe plug beside the gearbox sight-glass and tilt the vibro until the oil drains out.

Do not overfill the gearbox. Gearbox oil is viscous when cold. Add one gallon, allow the oil to spread out, then fill the remainder slowly while watching the sight glass.

When replacing either of the pipe plugs, add sealing tape to make sure oil and containments cannot enter or leave the gearbox.

## MAINTENANCE & TROUBLESHOOTING

### BLEEDING THE CLAMP CYLINDERS

As part of setting up a unit for service and regular maintenance, air and old oil must be bled from the hydraulic hoses.



**USE CAUTION NEAR OPEN HOSES. DO NOT TOUCH ANY AREA WITH ESCAPING OIL. HIGH PRESSURE OIL IS A SERIOUS HAZARD.**

1. Engage clamp CLOSE to extend all cylinders completely.
2. Disconnect the clamp hose at the Clamp OPEN Port on the Clamp.
3. Place the loose hose end in a bucket that can accept waste oil.
4. Engage clamp OPEN until all air has left the line and there is at least 3/8ths of a gallon in the bucket.
5. Release the clamp OPEN button and reconnect the fitting to the clamp.
6. Engage clamp OPEN to retract all cylinders completely.
7. Disconnect the clamp hose at the Clamp CLOSE Port on the Clamp.
8. Place the loose hose end in the bucket.
9. Engage clamp CLOSE until all air has left the line, emptying approximately 3/8 gallon into the bucket.
10. Release the Clamp CLOSE button and reattach the fitting to the clamp.

### INSTALLING A CLAMP ATTACHMENT

The vibro is usually shipped with the hydraulic clamp already attached and hooked up. If this is not so, or the job requires it to be removed and reattached later, a working knowledge of how to change the clamp is necessary. All bolts should be socket head cap screws. Do not use grade five bolts.



**IF ANY ONE ATTACHMENT BOLT BREAKS REPLACE ALL OF THEM. NEVER OPERATE THE VIBRO WITHOUT ALL ATTACHMENT BOLTS IN PLACE.**

1. Clean all drilled and tapped threads on the bottom surface of the gearbox with brake wash and a 1.5-6 UNC tap, removing any metal fragments.
2. Clean the machined bottom of the gearbox and the surface of the attachment. Make sure the surfaces are flat, void of dirt, and aren't obviously damaged.
  - Failure to follow cleaning steps will prevent bolts from tightening, causing them to break.
3. Orient the attachment holes with those of the vibrator, centering it on the gearbox.
4. Using anti-seize on each bolt, insert the center bolt first and work outwards. Do not tighten bolts until all are installed or while the attachment is hanging from the vibrator.
5. Tighten bolts according to the torque specifications at the end of this manual.
6. After vibrating the first pile retorque the bolts.

# MAINTENANCE & TROUBLESHOOTING

## CHECKING BEARINGS AND ECCENTRICS

Periodic maintenance and some vibro symptoms require the gearbox bearings to be inspected. The results of this inspection may indicate that the eccentrics require replacement.

During this check make sure no dust, dirt, or other contaminants can enter the gearbox.

If this procedure is being followed as part of regular maintenance only one cover needs to be removed and examined. If a problem is suspected all covers should be removed and inspected.

1. Remove one gearbox bearing cover.
2. Clean the bearing face. Examine both the bearing face and the interior of the bearing cover for wear or scorch marks.
3. Check the stamping on the outer ring of the bearing. There should be letters etched top.
  - If the lettering is not on top, tap the bearing with a rubber mallet to check if it is loose. If it is loose, replace it and check the eccentrics.
4. Inspect all visible components for chipping, pitting, corrosion, or deformation.
5. If no damage is found, apply lube to the bearing cover o-ring. Re-seat it, then attach the bearing cover to the gearbox with loctited bolts.

It is often difficult to determine if the eccentrics are damaged. In general, damage to a bearing requires the replacement of an eccentric. To check the eccentrics:

1. Unbolt and remove the suppressor and gearbox top plate.
2. Inspect eccentrics for chipping, pitting, corrosion, or deformation.
3. Replace damaged eccentrics and bearings, if necessary.
4. Apply fresh lube to o-ring cord before sealing gearbox.



*Etched words of manufacture location example: "USA" should be top center of bearings. If lettering is not on top, tap on the bearing with a rubber mallet to check if it is loose.  
Note: not all bearings are made in USA.*



*Metal flakes have pooled at the bottom of this bearing. It needs to be replaced.*



*Damaged eccentric bearing in need of immediate replacement.*



**ECCENTRICS MAY SWING UNEXPECTEDLY AND ARE HEAVY. THE INTERIOR OF THE GEARBOX IS A MAJOR PINCH AND CRUSH HAZARD WHEN OPEN.**



# MAINTENANCE & TROUBLESHOOTING

## TROUBLESHOOTING CHART

SYMPTOM	POSSIBLE CAUSE	SOLUTION
<u>Oil blowing out between gearbox and hydraulic motor</u>	<ol style="list-style-type: none"> <li>1. Blocked case drain.</li> <li>2. Breather plugged or damaged.</li> <li>3. O-rings not sealing properly.</li> </ol>	<ol style="list-style-type: none"> <li>1. Ensure case drain hose is attached and not kinked.</li> <li>2. Remove and clean breather, replacing if damaged.</li> <li>3. Verify o-ring seal and cleanliness between gearbox and motor.</li> </ol>
<u>Vibro gearbox overheating at the bearing covers</u>	<ol style="list-style-type: none"> <li>1. Vibro is being run too hard.</li> <li>2. There is too much or too little oil in gearbox.</li> <li>3. Gearbox oil is damaged.</li> </ol>	<ol style="list-style-type: none"> <li>1. Check that the unit is penetrating at least 1 inch of soil for every 30 seconds of operation. Allow the vibro to cool down between sessions of hard operation.</li> <li>2. Set the gearbox upright and level and check the sight glass. If the oil level is too high remove the sight glass and allow some to drain. If it is too low replace missing oil.</li> <li>3. Check oil quality in sight gauge and drainage plug. For oil that is black, milky, or contains large metal flakes see the next symptom on this chart.</li> </ol>
<u>The gearbox oil is discolored or contains contaminants</u>	<ol style="list-style-type: none"> <li>1. Gearbox oil has a dark or milky appearance from water, hydraulic oil, or dirt.</li> <li>2. Damaged bearings or eccentrics are leaving metal flakes or brass chunks.</li> </ol>	<ol style="list-style-type: none"> <li>1. Check all seals, especially those near the hydraulic motor, hoses, and the gearbox exterior for damage, breaches, or faulty o-rings.</li> <li>2. Perform the check bearings and eccentrics procedure. If damage is found replace the components and gearbox oil.</li> </ol>
<u>Gearbox is filling with oil</u>	Hydraulic oil is entering the gearbox through a bad motor seal.	Remove the hydraulic motor and check for damage to the o-ring or gearbox.
<u>Opening and closing clamp jaws seems spongy or slow</u>	<ol style="list-style-type: none"> <li>1. The clamp cylinders are dirty or inadequately lubricated.</li> <li>2. Clamp hoses contain air.</li> </ol>	<ol style="list-style-type: none"> <li>1. Inspect and lubricate clamps, clearing dirt as needed.</li> <li>2. Follow the Bleeding the Clamps procedure as described earlier in this manual.</li> </ol>
<u>Vibro won't come up to normal operating speed</u>	<ol style="list-style-type: none"> <li>1. Power unit at low RPM.</li> <li>2. Hoses are damaged or kinked.</li> <li>3. Defective or damaged hydraulic motor.</li> <li>4. Power unit pumps need repaired.</li> </ol>	<ol style="list-style-type: none"> <li>1. Raise the Power unit engine RPM.</li> <li>2. Check all hose connections and fix any loose or kinked lines.</li> <li>3. Perform the Checking Hydraulic Motors procedure. Replace a motor that shows damage.</li> <li>4. Contact a Qualified Service Technician to service or replace the power unit pump.</li> </ol>



# MAINTENANCE & TROUBLESHOOTING

## TRUBLESHOOTING CHART

SYMPTOM	POSSIBLE CAUSE	SOLUTION
<u>An attachment bolt broke</u>	Bolts didn't fully seat or are overstressed.	Replace all clamp bolts with special attention paid to cleaning all surfaces. Check working loads to ensure they're within acceptable levels.
<u>Clamps won't close when CLOSE switch is engaged</u>	<ol style="list-style-type: none"> <li>Hoses not properly routed.</li> <li>Bubbles are trapped in the line.</li> </ol>	<ol style="list-style-type: none"> <li>Double check hose hookups.</li> <li>Perform Bleeding the Clamps procedure as described earlier in this manual.</li> </ol>
<u>Vibro won't start when DRIVE button is engaged</u>	<ol style="list-style-type: none"> <li>The Vibro won't drive while the clamp is open.</li> <li>Hoses not connected properly.</li> <li>The hydraulic motor is damaged.</li> <li>Gearbox seized up.</li> </ol>	<ol style="list-style-type: none"> <li>Make sure the clamps are fully closed and the clamp light is on at the joystick.</li> <li>Check hose connections at the Vibro Pigtails, Qd, and Power unit.</li> <li>Follow Checking Hydraulic Motors procedure.</li> <li>Inspect the gearbox, bearings, and eccentrics. If there is damage found consult APE for repair and/or replacement.</li> </ol>
<u>Clamp won't open when OPEN switch is engaged</u>	<ol style="list-style-type: none"> <li>The vibrator is running.</li> <li>Hoses not properly routed.</li> </ol>	<ol style="list-style-type: none"> <li>Clamp won't open while vibro is in operation.</li> <li>Double check hose hookups.</li> </ol>

MAINTENANCE & TROUBLESHOOTING



## ORDERING REPLACEMENT PARTS

### Unit Information

Provide the serial and model number of the unit when contacting APE for replacement parts. This information can be found on a tag like the one on this page. Confirm all orders in writing to avoid duplicating shipments.

### Original and Modified Equipment

The previous equipment breakdowns apply only to equipment originally furnished with the unit. Any equipment that has been changed or upgraded won't be accurate to these schematics.

### Shipment

If the shipment recipient and method of shipment isn't stated then APE will use its own judgment.

### Shortages

APE does not assume responsibility for any delay, damage, or loss of material while in transit. Damaged or lost material should be refused or a full description made of its condition to the carrier agent on the freight or express bill. Make any such claims immediately upon receipt of parts.

### Return of Parts

If for any reason you desire to return parts to the factory or to any distributor from whom these parts were obtained, you must first secure permission to return the parts. Shipping instructions will be given along with this permission. A ten percent handling charge must be assessed against the returned shipment unless an error is made by the factory or by the distributor when filling your order.



*A tag with identifying numbers for the unit.*



# Replacement Parts

## OUTER SUPPRESSOR SUBASSEMBLY

P/N: 1008945

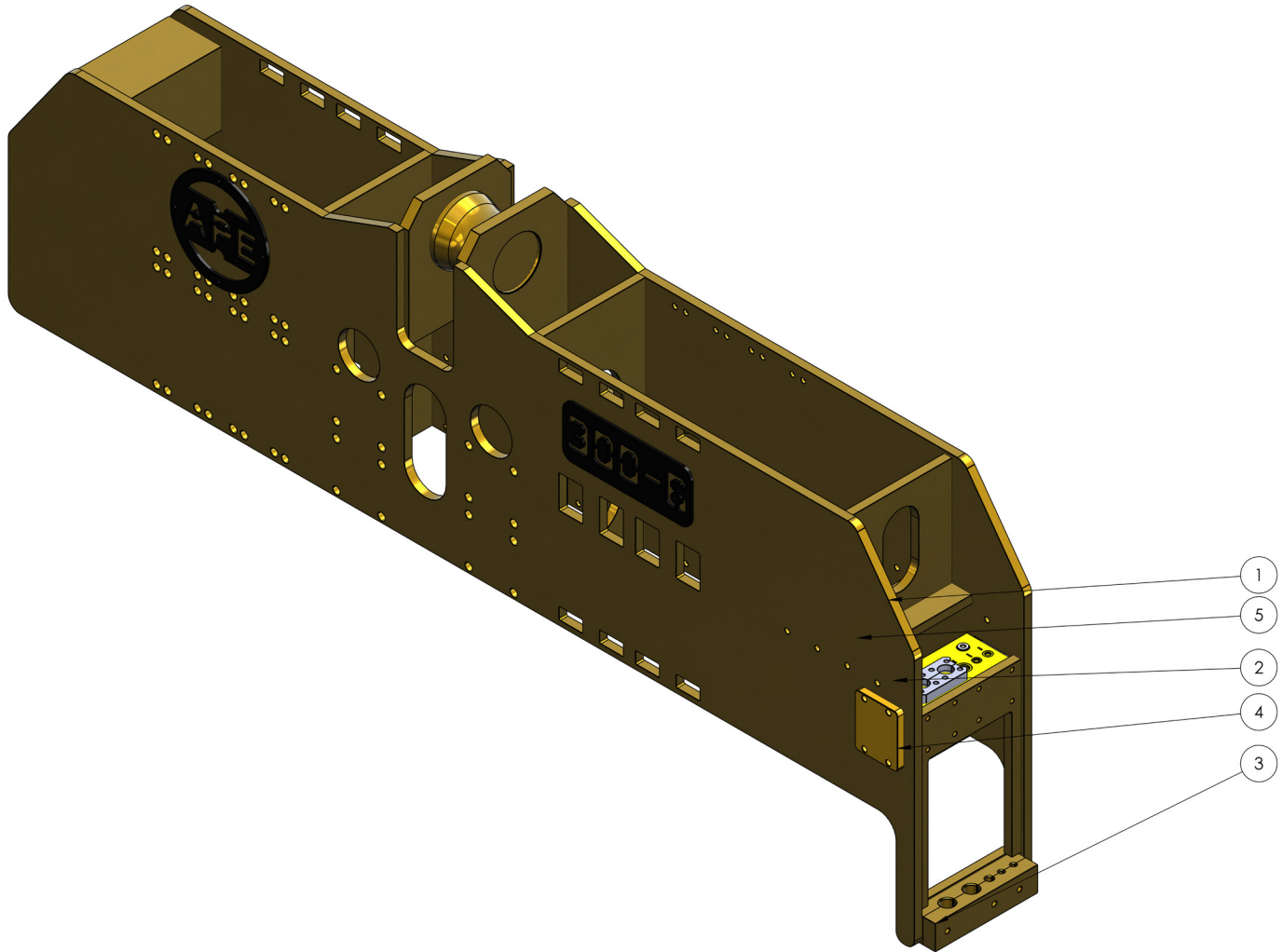

REPLACEMENT PARTS

ITEM NO.	PART NO.	DESCRIPTION	QTY
1	1009308	300-6 NEW STYLE OUTER SUPP MACH	1
2	1007027	BRAKE VALVE ASSEMBLY	1
3	1009307	HOSE CLAMP HALF	1
4	2000526	VALVE CARTRIDGE COVER, BRAKE VALVE	1
5	2001060	LASER MOUNT ASM	1



## INNER SUPPRESSOR SUBASSEMBLY

P/N: 1009305

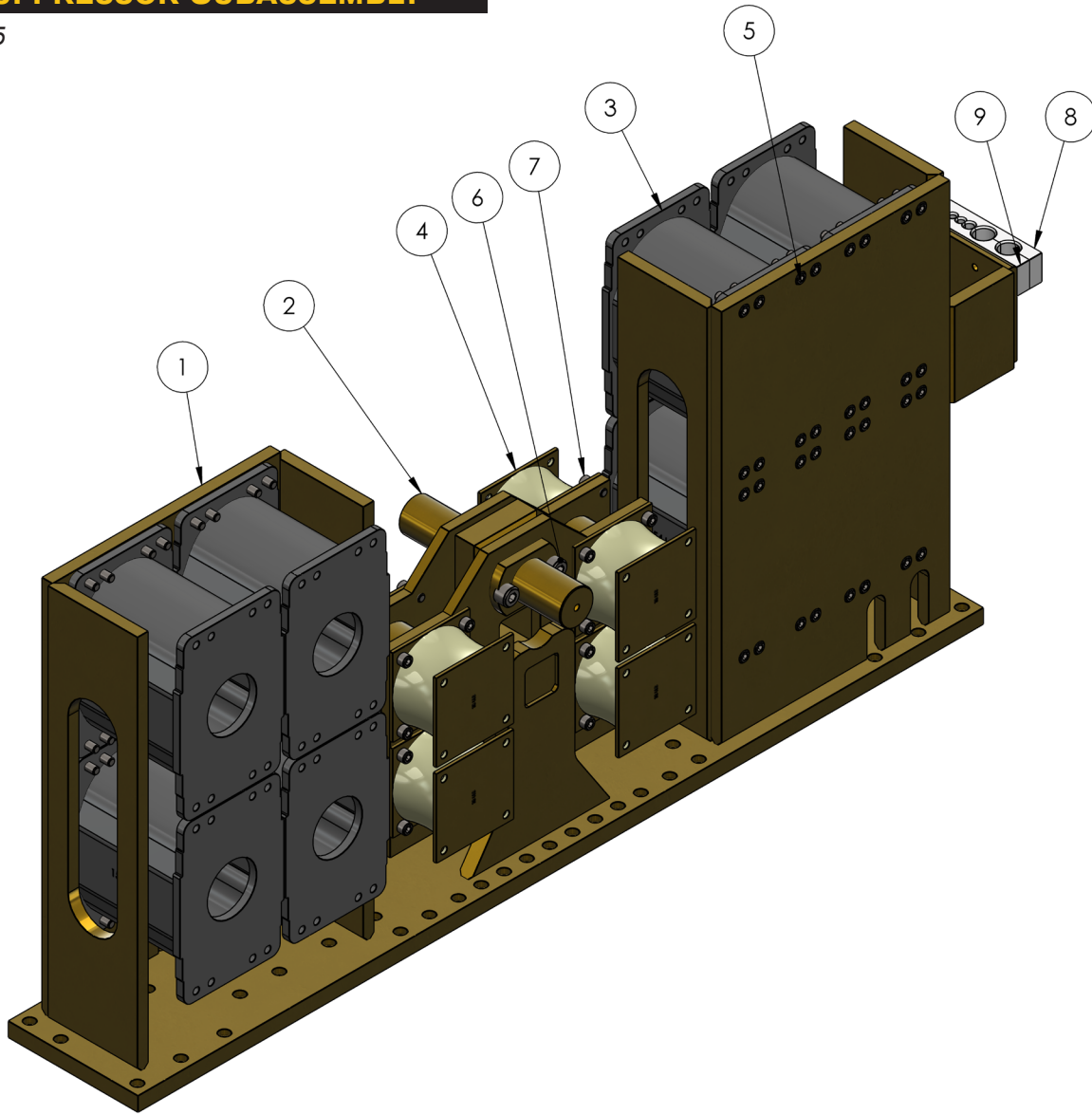

REPLACEMENT PARTS

ITEM NO.	PART NO.	DESCRIPTION	QTY
1	1009304	NEW STYLE INNER SUPP MACH	1
2	1009302	GUIDE PIN	1
3	321003	LARGE ELASTOMERS	8
4	321004	SMALL ELASTOMERS	8
5		STOVER NUT 0.75-10-D-N	64
6		HX-SHCS 0.75-10 X 2 X 2-N	64
7		HX-SHCS 0.75 -10 X 1.75 X 1.75-N	32
8	1009646	300-6 HOSE CLAMP TOP	1
9	1009647	300-6 HOSE CLAMP BOTTOM	1

# REPLACEMENT PARTS

## GEARBOX SUBASSEMBLY

P/N: 1008945

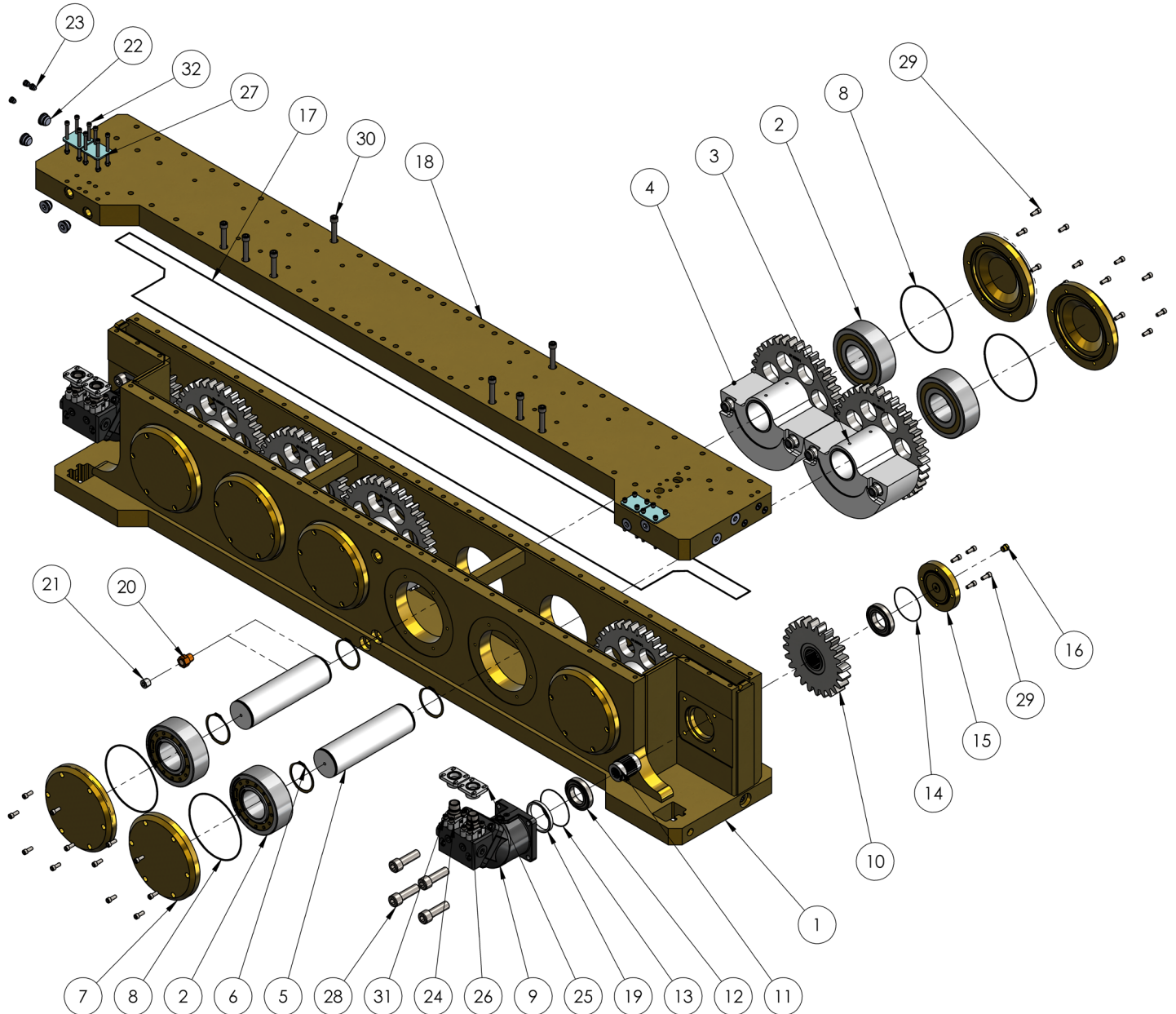

REPLACEMENT PARTS



## REPLACEMENT PARTS

Item No.	Part No.	Description	QTY
1	1008944	300-6 GEARBOX MACH W/12IN PITCH DIA DR-GEAR	1
2	1008997	NJ2324-E-MPAX-C4	12
3	1008951	ECCENTRIC GEAR ASSEMBLY-VALLEY	3
4	1008952	ECCENTRIC GEAR ASSEMBLY-PEAK	3
5	1008954	ECCENTRIC SHAFT	6
6	1008955	SH 475 EXT. RETAINING RING	12
7	1008956	ECCENTRIC BEARING COVER	12
8	110098	2-276 O RING	12
9	1004574	MA180 -095170B MOTOR	2
10	1008842	PINION GEAR	2
11	110370	PINION SHAFT (44)	2
12	110312	MOTOR BEARING	4
13	110195	2-163 O RING	2
14	170833	2-161 O RING	2
15	1008600	MOTOR BEARING COVER	2
16	122015	GEAR BOX BREATHER	2
17	1008996	GEARBOX TOP O RING	1
18	1008947	12IN PITCH DIA DR-GEAR-GEARBOX-TOP PL MACH	1
19	1008586	MOTOR BEARING BUSHING	2
20	123005	SIGHT GLASS	1
21		FIT-1" NPT PLUG	3
22		#20 SAE PLUG SOCKET	8
23		#8 SAE PLUG FLUSH	6
24	124233	#20 SPLIT FLANGE CODE 62	4
25	1007249	300-6 FEMALE COUPLER	4
26	1007551	300-6 MALE COUPLER	4
27		B1002-002 PLATE WASHER	4
28		HI ALLOY SPRING LW 0.75	8
29		HX-SHCS 0.75 -10X2X2 -N	8
30		HX-SHCS 0.5 -13X1.25X1.25-N	80
31		HX-SHCS 0.75-105X2-N	8
32		HI ALLOY SPRING LW 0.4375	16
33		HI ALLOY SPRING LW 0.5	16
34		HX-SHC 0.5-13X1.75X1.75-N	16
35		HX-SHCS 0.4375-14X5.5X1.375-N	16
36		HNUT 0.4375-14-D-N	16

REPLACEMENT PARTS



# REPLACEMENT PARTS

## BRAKE VALVE ASSEMBLY

P/N: 1007027

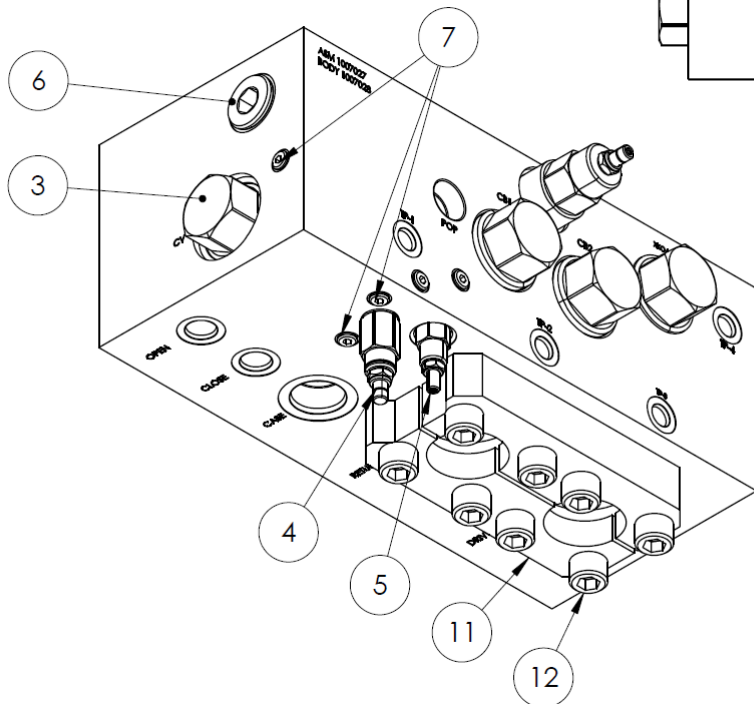
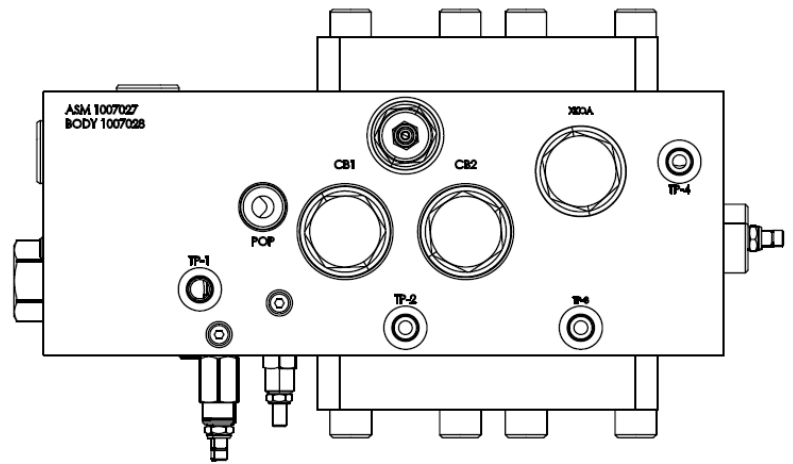
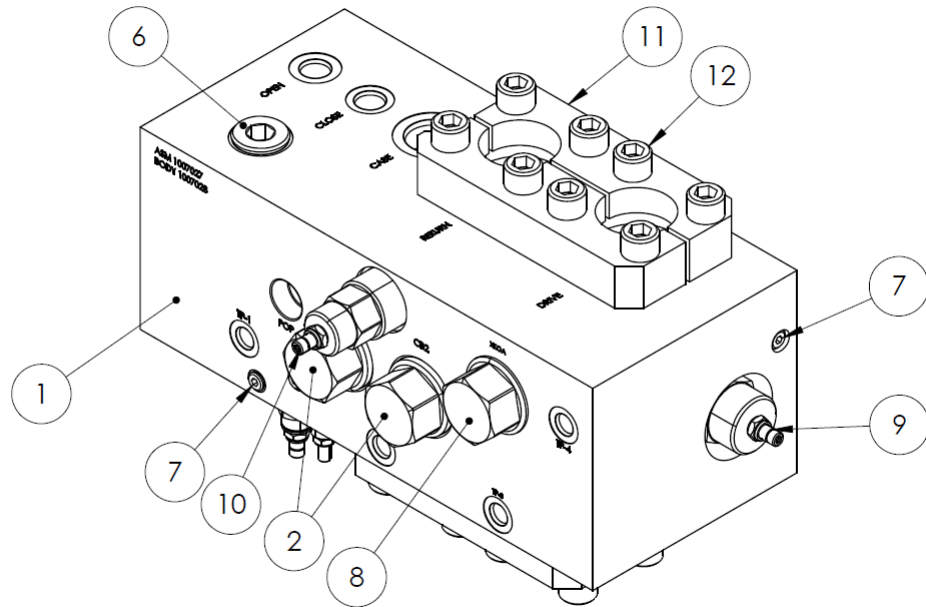

# REPLACEMENT PARTS

## BRAKE VALVE ASSEMBLY

P/N: 1007027

ITEM NO.	PART NO.	DESCRIPTION	DESCRIPTION 2	QTY
1	1007028	BRAKE VALVE BODY	HPS 018464	1
2	631073	POPPET VENT TO OPEN LOGIC VALVE	SUN LOKA-XDN	2
3	543105	CHECK VALVE	SUN CXJA-XCN	1
4		2 WAY PILOT SELECTOR VALVE	SUN DRBB-LEN	1
5	555195	DIRECT ACTING RELIEF VALVE	SUN RDBA-LCN	1
6	600189	#16 SAE MORB PLUG	BRE6408-H16-O	2
7	600184	#4 SAE MORB PLUG	BRE6408-H04-O	7
8	1000807	ALL PORTS OPEN CAVITY PLUG	SUN XKOA-XXN	1
9	400742	PISTON RELIEF VALVE	SUN RPKC-LCN	1
10		RELIEF VALVE	SUN RDHA-LAN	1
11	123021	DOUBLE SPLIT FLANGE		2
12	1003003	FLANGE MOUNTING BOLTS	SHCS 5/8" -11 X 2.50	16

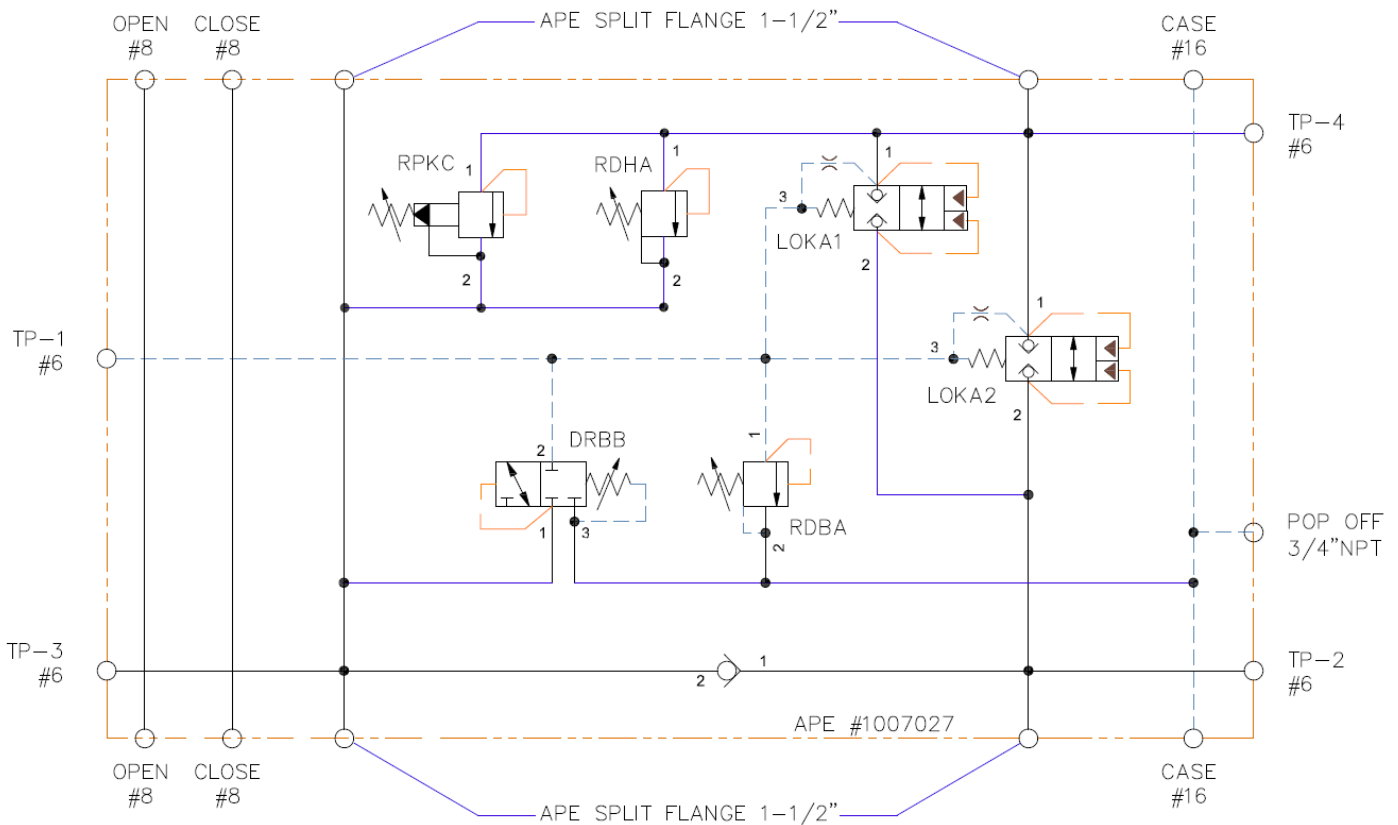

REPLACEMENT PARTS





## UNDERSTANDING ISO CODES

The ISO cleanliness code is used to quantify particulate contamination levels per milliliter of fluid at 3 sizes 4 $\mu$ [c], 6 $\mu$ [c], and 14 $\mu$ [c]. The ISO code is expressed in 3 numbers (ie 19/17/14). Each number represents a contaminant level code for the correlating particle size. The code includes all particles of the specified size and larger. It is important to note that each time a code increases the quantity range of particles is doubling.

ISO 4406 Chart		
Range Code	Particles per milliliter	
	More than	Up to/including
24	80000	160000
23	40000	80000
22	20000	40000
21	10000	20000
20	5000	10000
19	2500	5000
18	1300	2500
17	640	1300
16	320	640
15	160	320
14	80	160
13	40	80
12	20	40
11	10	20
10	5	10
9	2.5	5
8	1.3	2.5
7	0.64	1.3
6	0.32	0.64

Sample 1 (see photo 1)

Particle Size	Particles per ml*	ISO 4406 Code range	ISO Code
4 $\mu$ [c]	151773	80000~160000	24
6 $\mu$ [c]	38363	20000~40000	22
10 $\mu$ [c]	8229		
14 $\mu$ [c]	3339	2500~5000	19
21 $\mu$ [c]	1048		
38 $\mu$ [c]	112		

Sample 2 (see photo 2)

Particle Size	Particles per ml*	ISO 4406 Code range	ISO Code
4 $\mu$ [c]	492	320 ~ 640	16
6 $\mu$ [c]	149	80 ~ 160	14
10 $\mu$ [c]	41		
14 $\mu$ [c]	15	10 ~ 20	11
21 $\mu$ [c]	5		
38 $\mu$ [c]	1		

Photo 1

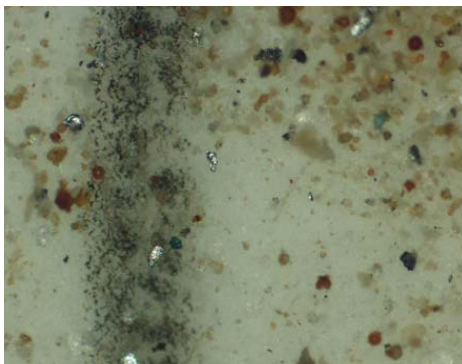

Photo 2





# TARGET ISO CLEANLINESS CODES

When setting target ISO fluid cleanliness codes for hydraulic and lubrication systems it is important keep in mind the objectives to be achieved. Maximizing equipment reliability and safety, minimizing repair and replacement costs, extending useful fluid life, satisfying warranty requirements, and minimizing production down-time are attainable goals. Once a target ISO cleanliness code is set following a progression of steps to achieve that target, monitor it, and maintain it justifiable rewards will be yours.

### Set the Target.

The first step in identifying a target ISO code for a system is to identify the most sensitive on an individual system, or the most sensitive component supplied by a central reservoir. If a central reservoir supplies several systems the overall cleanliness must be maintained, or the most sensitive component must be protected by filtration that cleans the fluid to the target before reaching that component.

### Other Considerations

Table 1 recommends conservative target ISO cleanliness codes based on a several component manufacturers guidelines and extensive field studies for standard industrial operating conditions in systems using petroleum based fluids. If a non-petroleum based fluid is used (i.e. water glycol) the target ISO code should be set one value lower for each size (4 μ[c]/6μ[c]/14μ[c]). If a combination of the following conditions exists in the system the target ISO code should also be set one value lower:

- Component is critical to safety or overall system reliability.
- Frequent cold start.
- Excessive shock or vibration.
- Other Severe operation conditions.

### Recommended\* Target ISO Cleanliness Codes and media selection for systems using petroleum based fluids per ISO4406:1999 for particle sizes 4μ[c] / 6μ[c] / 14μ[c]

	Pressure	Media	Pressure	Media	Pressure	Media
	< 140 bar	βx[c] = 1000	212 bar	βx[c] = 1000	> 212 bar	βx[c] = 1000
	< 2000 psi	(βx = 200)	3000 psi	(βx = 200)	> 3000 psi	(βx = 200)
<b>Pumps</b>						
Fixed Gear	20/18/15	22μ[c] (25 μ)	19/17/15	12μ[c] (12 μ)	-	-
Fixed Piston	19/17/14	12μ[c] (12 μ)	18/16/13	12μ[c] (12 μ)	17/15/12	7μ[c] (6 μ)
Fixed Vane	20/18/15	22μ[c] (25 μ)	19/17/14	12μ[c] (12 μ)	18/16/13	12μ[c] (12 μ)
Variable Piston	18/16/13	7μ[c] (6 μ)	17/15/13	5μ[c] (3 μ)	16/14/12	7μ[c] (6 μ)
Variable Vane	18/16/13	7μ[c] (6 μ)	17/15/12	5μ[c] (3 μ)	-	-
<b>Valves</b>						
Cartridge	18/16/13	12μ[c] (12 μ)	17/15/12	7μ[c] (6 μ)	17/15/12	7μ[c] (6 μ)
Check Valve	20/18/15	22μ[c] (25 μ)	20/18/15	22μ[c] (25 μ)	19/17/14	12μ[c] (12 μ)
Directional (solenoid)	20/18/15	22μ[c] (25 μ)	19/17/14	12μ[c] (12 μ)	18/16/13	12μ[c] (12 μ)
Flow Control	19/17/14	12μ[c] (12 μ)	18/16/13	12μ[c] (12 μ)	18/16/13	12μ[c] (12 μ)
Pressure Control (modulating)	19/17/14	12μ[c] (12 μ)	18/16/13	12μ[c] (12 μ)	17/15/12	7μ[c] (6 μ)
Proportional Cartridge Valve	17/15/12	7μ[c] (6 μ)	17/15/12	7μ[c] (6 μ)	16/14/11	5μ[c] (3 μ)
Proportional Directional	17/15/12	7μ[c] (6 μ)	17/15/12	7μ[c] (6 μ)	16/14/11	5μ[c] (3 μ)
Proportional Flow Control	17/15/12	7μ[c] (6 μ)	17/15/12	7μ[c] (6 μ)	16/14/11	5μ[c] (3 μ)
Proportional Pressure Control	17/15/12	7μ[c] (6 μ)	17/15/12	7μ[c] (6 μ)	16/14/11	5μ[c] (3 μ)
Servo Valve	16/14/11	7μ[c] (6 μ)	16/14/11	5μ[c] (3 μ)	15/13/10	5μ[c] (3 μ)
<b>Bearings</b>						
Ball Bearing	15/13/10	5μ[c] (3 μ)	-	-	-	-
Gearbox (industrial)	17/16/13	12μ[c] (12 μ)	-	-	-	-
Journal Bearing (high speed)	17/15/12	7μ[c] (6 μ)	-	-	-	-
Journal Bearing (low speed)	17/15/12	7μ[c] (6 μ)	-	-	-	-
Roller Bearing	16/14/11	7μ[c] (6 μ)	-	-	-	-
<b>Actuators</b>						
Cylinders	17/15/12	7μ[c] (6 μ)	16/14/11	5μ[c] (3 μ)	15/13/10	5μ[c] (3 μ)
Vane Motors	20/18/15	22μ[c] (25 μ)	19/17/14	12μ[c] (12 μ)	18/16/13	12μ[c] (12 μ)
Axial Piston Motors	19/17/14	12μ[c] (12 μ)	18/16/13	12μ[c] (12 μ)	17/15/12	7μ[c] (6 μ)
Gear Motors	20/18/14	22μ[c] (25 μ)	19/17/13	12μ[c] (12 μ)	18/16/13	12μ[c] (12 μ)
Radial Piston Motors	20/18/15	22μ[c] (25 μ)	19/17/14	12μ[c] (12 μ)	18/16/13	12μ[c] (12 μ)
<b>Test Stands, Hydrostatic</b>						
Test Stands	15/13/10	5μ[c] (3 μ)	15/13/10	5μ[c] (3 μ)	15/13/10	5μ[c] (3 μ)
Hydrostatic Transmissions	17/15/13	7μ[c] (6 μ)	16/14/11	5μ[c] (3 μ)	16/14/11	5μ[c] (3 μ)

\*Depending upon system volume and severity of operating conditions a combination of filters with varying degrees of filtration efficiency might be required (i.e. pressure, return, and off-line filters) to achieve and maintain the desired fluid cleanliness.

Example	ISO Code	Comments
Operating Pressure	156 bar, 2200 psi	
Most Sensitive Component	Directional Solenoid	19/17/14 recommended baseline ISO Code
Fluid Type	Water Glycol	18/16/13 Adjust down one class
Operating Conditions	Remote location, repair difficult	Adjust down one class, combination
	High ingestion rate	17/15/12 of critical nature, severe conditions

## REFERENCE / NOTES

# RECOMMENDED BOLT TIGHTENING TORQUE “LUBRICATED SHCS”

Socket Head Cap Screws

When installing any APE equipment or parts apply lubricant and use APE standard **Anti-Seize** torque specs. See Tightening Torque Spec below. Failure to follow tightening torque spec can result in under / over tightening fasteners, leading to equipment failure or personal injury.



### COARSE THREADS

Nominal Screw Size	Nominal Socket Size	Tightening Torque (ft-lbs)
#10-24	5/32	6
.25-20	3/16	10
.31-18	1/4	22
.38-16	5/16	38
.44-14	3/8	61
.50-13	3/8	93
.63-11	1/2	179
.75-10	5/8	317
.88-9	3/4	511
1.00-8	3/4	767
1.25-7	7/8	1,533
1.50-6	1	2,668

### FINE THREADS

Nominal Screw Size	Nominal Socket Size	Tightening Torque (ft-lbs)
#10-32	5/32	6
.25-28	3/16	12
.31-24	1/4	24
.38-24	5/16	43
.44-20	3/8	68
.50-20	3/8	105
.63-18	1/2	202
.75-16	5/8	354
.88-14	3/4	564
1.00-12	3/4	860
1.25-12	7/8	1,697
1.50-12	1	3,001

## RECOMMENDED ANTI-SEIZE LUBRICANT

### BENEFITS & FEATURES

- **Excellent Anti-Seize** Prevents seizing causing by galling, galvanic action, fretting, fusion, pitting, thread distortion, breakage, rust, and corrosions.
- **Water Resistant** Provides long term protection with just one application, outdoors or indoors, even in the damp areas or against salt spray. Will not wash off.
- **Wide Temperature Range** Coating withstands temperatures of -65 Degree F to 2100 Degree F. (-54 C to 1100 C)
- **Stable Coating** Will not harden or fuse to metal, cake, evaporate or separate
- **Compatible with many materials** Can be used as an anti-seize on the threads of steel, stainless steel, steel alloy, cast iron, aluminum, copper brass, and titanium parts and reduces friction and wear on plastic.
- **Environmentally Desirable** Past contains no lead compounds traditionally found in this type of product.



**WARNING: USING OTHER TYPES OF ANTI-SEIZE NOT RECOMMENDED BY APE CAN LEAD TO EQUIPMENT FAILURE OR PERSONAL INJURY. WARRANTY WILL BE VOIDED AND FEES MAY APPLY.**



All information given in this Manual is current and valid per the information available at the time of publication. (Please check the updated revision date at the bottom of each page.)

American Piledriving Equipment (APE) reserves the right to implement changes without prior notice.

Please visit [www.americanpiledriving.com](http://www.americanpiledriving.com) for the most recent version of this publication.

AMERICAN PILEDRIVING EQUIPMENT, INC.

7032 S. 196th Street

Kent, Washington 98032

Office: 253-872-0141

Toll Free: 800-248-8498

Fax: 253-872-8710