

Foreword

This manual will help users operate and maintain the drill rig correctly. The manual supplied with the drill rig is primarily intended for use by operator. It is particularly important that the drill rig operator should read these instructions carefully not only prior to using the drill rig for the first time (in order to become acquainted with its operation and special features), but also so as to take full advantage of its capabilities during use, or for lubricating and servicing operations. Otherwise accidents or damage may occur.

The manual should be regarded as the permanent part of drill rig and kept in the cab for consultation at any time. And the manual should be attached when the drill rig is transferred or sold.

The drill rig is designed according to the metric system, all the data presented are metric and only metric parts and apparatus can be used. Position definition: RIGHT and LEFT always mean the left and right of an operator seated correctly in the drill rig. The drive sprockets of undercarriage are located at the rear.

For best drill rig performance, all instructions given in this manual should be complied with strictly. Possible warranty claims may be considered only provided that all operations are made by qualified operator and scheduled inspections are made at the specified times by qualified technician. Warranty claims will not be considered provided the drill rig is abused, overloaded, or if there are changes to the original functions of drill rig.

Regarding SAFETY in particular, we recommend carefully reading the SAFETY RULES in this manual and complying with all the safety rules. The equipment covered by this manual meets the applicable technical specifications effective as of its date of issue. The manufacturer SUNWARD reserves the right to make from time to time and without prior notice any modification or amendment of any nature, deemed useful or necessary, to any drill rig component, without any obligation to amend the content of this manual accordingly. Pictures and data contained in this manual are not binding. Consequently, no claim raised in this respect will be considered.

American Piledriving Equipment, Inc.

TABLE OF CONTENTS

§1 Safety Information	3
§2 Description	14
§3 Technical Specification	17
§4 Main Component Structure and Working Theory	22
§4.1 Construction Procedure for Drilled Shaft	22
§4.2 Drill Rig Structure and Basic Principle	22
§4.2.1 Undercarrage	22
§4.2.2 Turntable	24
§4.2.3 Mast and Parallelogram System	24
§4.2.4 Main and Auxilary Winch	25
§4.2.5 Rotary Head	25
§4.2.6 Kelly Bar and Drilling Tool	27
§4.2.7 Engine	28
§4.2.8 Hydraulic System	28
§5 Electrical System	33
§5.1 Description	33
§5.2 DESARS Intelligent Control System	33
§5.2.1 Main Control Panel	35
§5.2.2 Debug Panel	35
§5.2.3 Work Panel	37
§5.2.4 Debug Panel	38
§5.2.5 Monitor Panel	39
§5.2.5.1 Instrument Monitor Panel	39
§5.2.5.2 Sensor Malfunction and Dignostic Panel	41
§5.2.6 Setup Panel	42
§5.2.7 Recording Panel	42
§5.3 Control and Operation of Engine's Auxilary Appliances	44
§5.3.1 Main Power Open and Auxilary Appliances Control	44
§5.3.2 Engine Start up	46
§5.3.3 Engine Shut Down	46
§5.4 Control During Drilling	46
§5.4.1 Drill Rig Moving Mode	46
§5.4.2 Drill Rig Drilling Mode	47
§5.4.3 Other Operation Control	50
§5.4.4 Interlock and Protection	50
§5.5 Engine Malfunction Indication and Code Chart	52
§6 Operation	54
§6.1 Inspection and Preparation Before Starting the Engine	55
§6.2 Operation and Instruments	55
§6.3 Operation	55
§6.3.1 Drill Rig Positioning	55
§6.3.2 Rigging up	56

§6.3.3 Hole Opening and Casing Installation	59
§6.3.4 Drilling	58
§6.3.5 Drill Rig Moving	60
§6.3.6 LCD Monitor Display	60
§6.3.7 Shut Down.....	61
§6.3.8 Steps to Exit From Drilling Mode to Transportation Mode	62
§7 Maintenance and Service	63
§7.1 Bolts and Nuts Tightening.....	63
§7.2 Fuel.....	63
§7.3 Hydraulic Oil.....	63
§7.4 Lubrication Oil(Fat)	63
§7.5 Coolant	64
§7.6 Maintainance	64
§8 Transportation	70
§8.1 Trailer Transportation.....	70
§8.2 Break-down Transportation.....	70
§9 Trouble Shooting.....	70

§ 1 Safety Rules

§ 1.1 Safety Mark

The figure to the right is a safety reminder. When you see this mark on the drill rig or in the manual, it indicates that you may be in danger of injury.



§ 1.2 Safety Label

There are various labels at various places on the drill rig indicating various risks, such as Danger, Warning, Attention, etc (right figure), they have the following meaning:

Danger---Direct danger. It will cause death or grievous bodily harm (GBH) if accident occurs.

Warning---Potential danger. It may cause death or GBH if accident occurs.

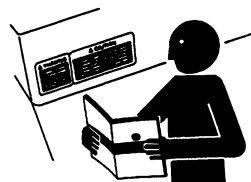
Attention---Potential danger. It may cause flesh or moderate wound.

Danger, Warning safety labels are placed at given locations of the drill rig in the possible dangerous area. General attentions are listed on the “Attention” safety label. In this manual, “Attention” is also used to remind of safety instruction.



§ 1.3 General Safety Instruction

- Read the manual carefully and follow the safety instructions on the labels and manual before operating the drill rig.
- Always keep the safety labels clean. Change any lost or damaged labels with new ones. If the labels or manual are lost, you can contact the dealer and indicate the model of drill rig to purchase.
- Only trained and qualified operators are permitted to operate this drill rig. Keep the drill rig in good condition as per this



manual.

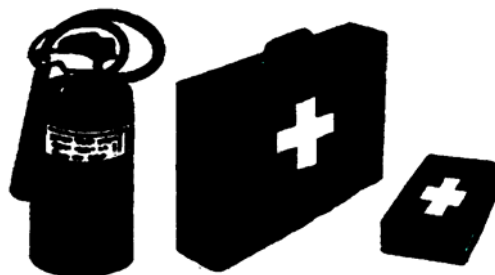
- Do not modify the drill rig without prior authorization, otherwise it will affect the performance and service life of the drill rig, or may cause injuries to human body.

ATTENTION: The safety instructions in this manual include only the general safety rules of the drill rig. Not all possible danger is covered. Should any problems occur, please report to your superior before operating and maintaining the drill rig.



§ 1.4 Preparation For Emergency

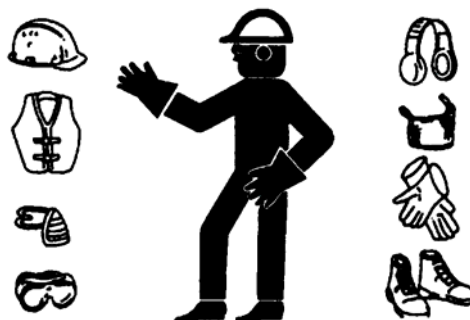
All personnel related to operating the drill rig should pay attention to prevent accidents from happening. Always keep a first-aid kit and fire extinguisher nearby. Have phone numbers of a doctor, ambulance, hospital, and fire department with you in case of emergency.



§ 1.5 Wear Safety Protective Gear

Before operation, always wear protective gear as the work requires, this includes:

- Tight work clothes
- Hard hat
- Safety gloves
- Safety glasses, goggles, or shield
- Dust mask or respirator
- Earplug



§ 1.6 Check Drill rig Before

Start-up

Before each day or shift, check the drill rig according to the “Check drill rig before start-up” section.

§ 1.7 Adjust Operator Seat

You may adjust seat to suit yourself, Lean your back on the back of seat and let your feet reach the pedals.

§ 1.8 Enter or Leave Drill rig

Always face the drill rig when you use the steps and hand-holds to enter or leave drill rig. Never use any control lever as a handhold. Never enter or leave drill rig when the drill rig is traveling, swinging, or drilling.

§ 1.9 Start Engine

The operator must sit on cab seat to start engine. Standing on the crawler to start engine is not permitted. Hot wire start-up (including terminal start-up) is not permitted.

§ 1.10 No Passenger Allowed In The

Cabin

When the drill rig is in operation or traveling, no passenger is allowed to stay on or in the drill rig except the operator.

§ 1.11 Keep Drill rig Away From Power Line

Any part or load of the drill rig touching power line will cause human death or GBH. Prohibit drill rig or its load from operating in close proximity to any power line. Keep the drill rig 3 meters (10feet) away from any power line(50,000KV or less) and follow OSHA rules.

ENGINE START-UP AND SHUT-DOWN

START-UP

1. MAKE SURE THE OPERATING HANDLE IS IN THE MIDDLE POSITION.
2. TURN YOUR KEY CLOCKWISE TO START THE ENGINE AND WAIT FOR THE PRE-HEAT LIGHT ON THE MONITOR GOES OFF, THEN CONTINUE TURN CLOCKWISE UNTIL THE ENGINE STARTS. AFTER ENGINE STARTS, RELEASE THE KEY AND THE KEY SHOULD RETURN TO "RUN" POSITION. STARTER SHOULD NOT CONSTANTLY WORK FOR MORE THAN 5 SECONDS. 30 SECONDS WAITING TIME IS REQUIRED BETWEEN EACH START-UP SHOULD THE FIRST START-UP FAIL.
3. AFTER THE ENGINE STARTS, SLIDE THE FUEL LEVER FROM LOW SPEED POSITION TO MIDDLE SPEED POSITION FOR 5 MINUTES TO WARM UP.

ENGINE RUNNING AFTER START-UP

1. BEGIN WORKING ONLY THE TEMPERATURE INDICATOR IS IN THE GREEN ZONE.
2. THE LIGHT ON THE MONITOR SHOULD GO OFF.
3. STOP THE ENGINE SHOULD YOU HEAR BEEP SOUND OR INDICATING LIGHTS ARE ON. PLEASE CHECK THE MACHINE BASED ON THE INDICATING LIGHTS.

SHUT-DOWN ENGINE

1. LET THE ENGINE RUN IN LOW SPEED FOR ABOUT 5 MINUTES AND LET THE ENGINE COOL GRADUALLY.
2. TURN THE KEY TO "SHUT-DOWN" POSITION



§ 1.12 Move Drill rig Safely

- Before the drill rig travels and swings, know the position of other people, and keep the drill mast backward 15° to avoid the drill rig tilting.
- Before the drill rig travels or swings, warn other people by tapping the horn.
- Hand signal should be used when operation or swinging is in confined area, and agree upon the hand signals before drill rig start-up.
- Know that the pedal/control levers are corresponding to the traveling direction before operate the drill rig.
- Raise drill mast and tool before moving drill rig. Stop the engine and take any necessary measures should the kelly bar fall.



§ 1.13 Prevent Accident While Backing Up or

Swinging

In order to prevent accidents while backing up or swinging, the operator must:

- Look around and confirm nobody is there before backing up or swinging.
- Ensure that other people are out of the working range. Warn other people by tapping the horn or using other signals before the drill rig moves,
- Keep a signal man within his(her) vision range if the operator's vision is obscured.
- Understand the meaning of flags, marks and signals before the drill rig moves or swings.
- Keep windows, mirrors, and lights clean.
- Use lights when visibility is obscured by dust, rain, fog, etc.
- Read carefully and understand the contents of this manual.



§ 1.14 Operate Safely

- All non-work related people should be kept away from the drill rig's working range.
- The jobsite **MUST** be hard enough to

support the drill rig, or use 2 steel plates to support the crawlers in order to prevent the drill rig from tipping over.

- When the drill rig works close to a hole, the tension wheel end should be towards the hole, the crawlers should be placed in a position such that the drill rig can move away easily in case of hole collapse.
- Hole location should be in the center line of the two crawlers. Leave enough space for the drill rig to swing or dump soil.

§ 1.15 Avoid Accident when The

Drill Rig Out Of Control

GBH or death may occur when attempting to climb onto a moving drill rig or trying to stop an out-of-control drill rig.

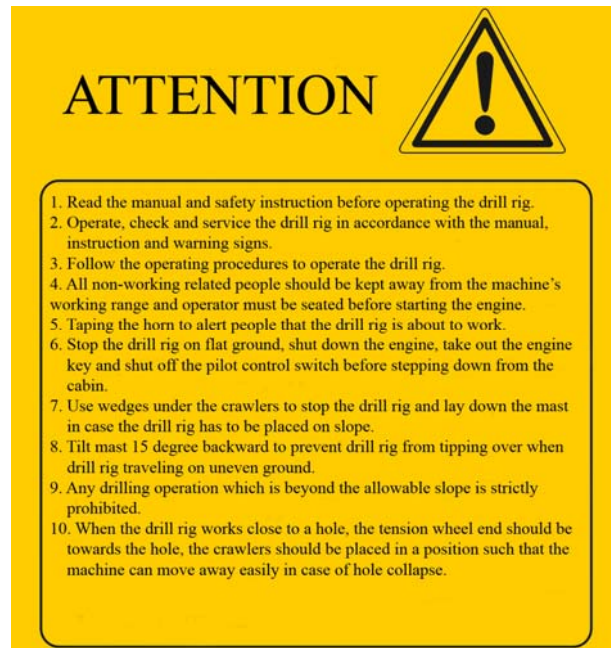
In order to prevent that from happening, pay attention to the following:

- Stop the drill rig on a flat ground and try to avoid stopping on slope. Shut down the engine according to the following procedures:
- Run engine at low RPM for 3 minutes to cool down the drill rig.
- Stop engine, take out key from key switch.
- Switch off hydraulic control switch by lifting the Left Console.
- Use chocks to block crawlers, and boom down the drill mast if the drill rig has to stay on slope.
- Secure the drill rig to prevent accidental movement.
- Keep the drill rig away from other machinery.
- Pin superstructure with undercarriage during transport.

§ 1.16 Park drill rig safely

Stop drill rig according to the following steps:

- Place drill rig on flat ground.
- Boom down the drill mast to horizontal position.



- Run engine at low RPM for 3 minutes to cool drill rig down.
- Slide the fuel handle to stop position; turn the ignition key to “OFF” position.
- Switch off pilot control by lifting the Left Console.
- Close window, sky window, and cabin.

§ 1.17 Safe Maintenance

- Maintenance Steps:

Keep the working area clean and dry.

Don't lubricate or maintain a moving drill rig.

Keep body and clothing from touching any moving parts.

- Preparation for maintenance:

Place the drill rig on flat ground.

Lower the mast foot on the ground or boom the mast down on the horizontal support bracket.

Run engine at low revs for 5 minutes.

Push fuel handle forward, stop engine, and take out key from the ignition.

Hang the “Drill rig out of Duty” plate at control lever.

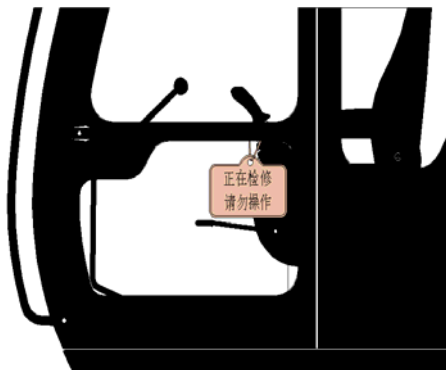
Switch off pilot control.

- Safety in maintenance

One person should remain inside the cabin if the maintenance must take place while the engine is running.

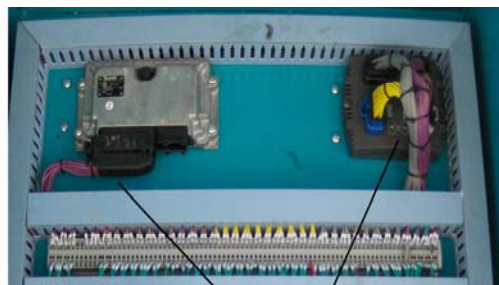
- Check some parts at regular intervals. Repair or replace, if necessary. (Refer to the “maintenance” chapter of this manual)
- Make sure all parts are in good condition and fit correctly. Replace worn or damaged parts. Clean any excess lubricant.

When adjusting electric system or welding on the rig, disconnect both positive and negative poles of battery and all the connections on PLC and Rexroth controls(see



ENGINE DAILY INSPECTION

1. CHECK OIL INDICATOR BEFORE START-UP. THE OIL INDICATOR SHOULD BE BETWEEN H AND L.
2. CHECK WATER INSIDE THE RADIATOR. USING CLEAN TAP WATER.
0-32 DEGREE CELSIUS: 50% Ethylene glycol AND 50% WATER MIXTURE;
-32 ~ -54 DEGREE CELSIUS: USING 60% Glycol AND 40% WATER MIXTURE.
3. DIESEL:
USING THE FOLLOWING DIESEL TYPE:
+4 DEGREE ABOVE (CELSIUS): # 0 DIESEL;
-5 DEGREE ABOVE (CELSIUS): # -10 DIESEL;
-15 DEGREE ABOVE(CELSIUS): # -15 DIESEL.
USING CLEAN DIESEL. NEVER USE LOW QUALITY, UNCLEAN DIESEL!
4. ENGINE DOES NOT WORK IF AIR IS INSIDE THE FUEL SYSTEM AND YOU MUST BLEED THE AIR OUT OF THE SYSTEM!
5. USING MANUAL FUEL PUMP TO BLEED AIR OUT AFTER REFILLING WHEN THE ENGINE STOPS.
(USING STARTER TO BLEED IF MANUAL FUEL PUMP NOT AVAILABLE)



UNPLUG ALL THE CONNECTIONS BEFORE WELDING

picture). Also, OEM 50-Pin connector on the Cummins engine should be unplugged; 4-Pin power plug on the Cummins engine should be unplugged.

§ 1.18 Support Drill rig Correctly

Prohibit repairing or maintaining drill rig before the drill rig is well supported.

Before maintenance, lower the drilling tools to the ground or lower the drilling mast on the bracket.

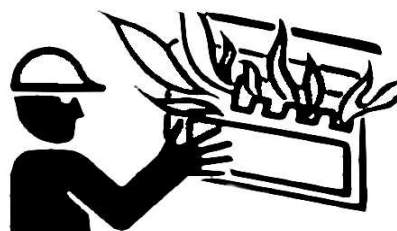
Don't support the drill rig on any slag, hollow brick, or fragile objects.

§ 1.19 Clean Trash From The Rig

Keep the engine, radiator, battery, hydraulic line, fuel tank, and cabin clean.

After stopping engine, the engine temperature may rise immediately. Open engine compartment doors to cool engine as soon as possible and clean engine apartment.

Clean drill rig at regular intervals, eliminate excess lubricant and other trash. Do not spray water or vapor into cabin.



§ 1.20 Prevent Battery Explosion

Prohibit fire or flame close to the battery top, battery gas may cause explosion.

Check the electric charge with a voltage meter or gravimeter. Do not place metal bestriding connection rod to check electricity deposit.

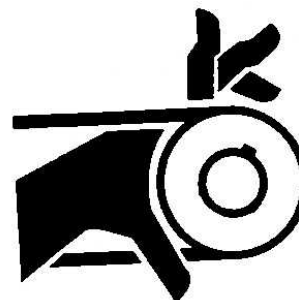
Never charge a frozen battery, otherwise it will explode. The battery should be warmed up to

16° C (60° F).



§ 1.21 Grinding Safely

Minimize grinding dust and debris by appropriate means. Wear goggles. Keep people away from work area to avoid accidents.



§ 1.22 Prevent Parts From Flying Off

Off

The grease in the crawler tension unit is under high pressure. To avoid injury, do not discharge grease cup or valve. Also keep your body and face away from any valves in case any unexpected parts fly off.

§ 1.23 Keep Away From Transmission

Parts

Touching transmission parts may cause GBH. When you work around the transmission parts, pay attention not to let your hand, foot, hair or clothes touch the drill rig.

§ 1.24 Prevent Inhaling Asbestos

Dust

Prevent inhaling possible asbestos dust. The asbestos fiber may cause lung cancer.

Some seals contain asbestos fiber. In these components, normally, the asbestos is in the resin or kept closed. If the asbestos containing parts don't cause dust, there isn't any danger in normal disposal.

In order to prevent dust, don't clean with compressed air, and avoid brushing and grinding asbestos-contained materials. In maintenance work, wear regulated respirator, and use a special dust collector to clean asbestos. If dust collector is not available, use a little oil or water to damp the asbestos-contained material. Comply with working area rules and asbestos disposal rules. Keep other people from entering in working area.



§ 1.25 Beware Of Inhaling Smoke or

Exhaust Gas

Inhaling exhaust gas may cause disease, or even death.

If the drill rig is operated inside a building, open windows and doors to ensure sufficient ventilation, or use long exhaust pipe to discharge smoke.



§ 1.26 Beware of Scalding

During operation, engine oil, gear oil, hydraulic oil will become hot. Also engine, hose, exhaust pipes, and other parts will also become hot. Beware of scalding.

Carry out inspection and maintenance after oil and parts have cooled to prevent scalding. The hydraulic oil tank and pipeline are high pressured. Before maintenance or replacement, the pressure should be released to avoid hot oil erupting.

§ 1.27 Be Careful Of Pressured

Liquids

Liquids in high pressure can penetrate through skin, causing GBH.

Release pressure before disconnecting any pipes to avoid this.

Operate control lever many times to release pressure.

Before pressurizing, tighten all the connections.

Inspect leakage with cardboard. Pay attention to protect your hand and body.

If accident occurs, see a doctor at once.

Any liquid penetrating the skin must be cleaned within a few hours, otherwise it will cause tissue decay.

§ 1.28 Avoid Heating Near A Pressured Oil

Pipe

To prevent severe burns, do not weld or flame cut near pressured oil pipe or other flammable materials.

A temporary fireproof protection cover should be provided when welding, flame cutting or gas welding takes place.

§ 1.29 Avoid Heating Flammable Liquid Pipe



Pipes with flammable liquid are not permitted to be welded. Pipes or hoses must be cleaned completely with incombustible solvent should any welding be required on those pipes.

§ 1.30 Remove Paint Before Welding or

Heating

Prevent potential poisonous gas and dust.

When paint is heated up by welding or other methods, it will produce poisonous gas.

Remove paint by the following methods before welding or heating:

- Wear a regulated mask to prevent inhaling dust when removing paint with abrasive paper or sand wheel.
- Remove paint with solvent or paint remover. Clean paint remover with soap and water and wait for about 15 minutes for solvent to evaporate before welding.

Paint removal work should be conducted outdoors or in a well ventilated area.

§ 1.31 Liquid Disposal

All fuels, most lubricants, and some coolants are flammable. These flammable liquids should be stored away from fire. Do not burn or punch any liquid containers. Dispose of fuel carefully; stop engine before adding fuel; prohibit smoking while adding fuel. Add fuel outdoors.

Do not put oil-containing rags on the drill rig to ensure the drill rig stays clean.

§ 1.32 Chemical Disposal

Touching harmful chemicals directly will cause serious injury to the human body. The chemicals used in this drill rig, such as lubricant, coolant, paint, and adhesive may be harmful. Before using harmful chemicals, check and understand its danger; know how to use them safely.



§ 1.33 Fire Prevention

Following these steps to prevent fire:

Prevent fire caused by leakages of fuel, hydraulic oil and lubricant.

Inspect clamps and ensure they are intact, check hoses and pipes to see they are in the right position; check hydraulic oil cooler, connections; check leakage using a piece of cardboard; never check leakage by hand.

Tighten, repair, or replace any clamps, pipes, hose, oil cooler, and flange bolts of oil cooler.

Do not twist or punch any high-pressured pipe.

Do not use any twisted or damaged pipe or hose.

- Inspect short circuits. Short circuiting of the electric system can cause fire. Check cables and wires before every shift or after 8 hours operation.

Check connectors before every shift or after 8 hours operation.

Tighten, repair, or replace any loosened or damaged cables, wires and connectors before operation. Do not operate the drill rig if the cables and wires are not in good condition.

- Repair switch
Check key switch and engine emergency stop switch before everyday operation. Repair immediately if they are not functioning.

Fire might be even worse or GBH might happen if engine can not be stopped in case of fire.

Clean out flammable materials

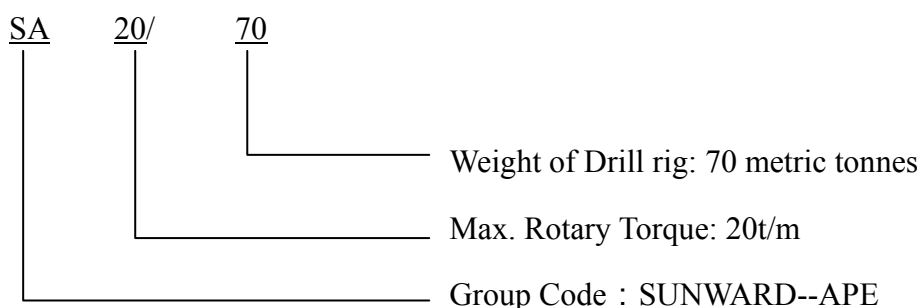
Spilled fuel, excessive coal dust, and other flammable materials may cause fire. Keep the drill rig clean every day to prevent fire.



§2 DESCRIPTION

SA-20/70 rotary drill rig is designed for cast-in-drilled-hole construction and widely used in foundation construction of roads, bridges, wharves and high-rise buildings with many features like high torque, high mobility and high efficiency. Equipped with long or short auger, drilling bucket, core barrel or hydraulic hammer, it can be used in drilling clay, sand, gravel or medium weathered rock layers.

§ 2.1 Model Definition



§2.2 Applicable Range

Use short auger for clayed soil, silty soil, backfilling, medium density sand and weathered rock layers above water table.

Use drilling bucket with slurry for clayed soil, silty soil, sand, backfill, gravel and weathered rock layers below water table.

Use rock auger for gravel, medium hard rock and weathered rock layers.

Use core barrel for weathered rock layer and cracked rock layer.

§2.3 Operation Condition

Ambient temperature should be $-15^{\circ}\sim+45^{\circ}\text{C}$ ($60^{\circ}\sim113^{\circ}\text{F}$) and ground gradient should be less than 5° . Stop working and boom down drill mast when rainstorm occurs or wind speed is more than 15m/s (34mph).

§2.4 Features

1. Special designed undercarriage, big roller winch, excellent stability, long wire rope service life.

SA-20/70 hydraulic drill rig utilizes hydraulic retractable undercarriage. The main and auxiliary winches are installed on the swing platform for stability of the drill rig. Large

diameter roller winch reduces wire rope layers and increase wire rope service life.

2. Patented parallelogram system, high torque, high mobility

Computerized design, simple hinge connection, high torque and parallelogram system for excellent stability. Drilling mast can be rigged or boomed down no matter where the rotary head and Kelly bar are located for easy transportation.

3. Easy load and unload

Drilling mast can be boomed down and extended by its own parallelogram system without additional equipment. Safety is ensured and rigging/unrigging becomes easy at site.

4. Multifunctional Mast Foot

A hydraulic mast foot is built at the bottom of drilling mast for easy casing installation, crawlers retract / extend and maintenance.



5. Rotary head

The rotary head uses two hydraulic motors, two speed transmission reduction with circulating lubrication system to enhance lubrication and cooling effect. Anti-shear structure and optimized consumable parts make the rotary head more reliable. Both interlocking and friction kelly bars are used for the rotary head. Crowd cylinder pushing force reaches to 40,786 lbs, lifting force reaches to 46,297 lbs. The cylinder stroke is 197 inches.

6. Patented electronic control system with features and various functions for reliable and easy maintenance

Intelligent control technology, CAN BUS technology and virtual monitor technology, embedded controller, true color LCD screen and SUNWARD DESARSR electronic control system are employed in the system. The system is precise, fast, stable with available Chinese (or English) computer interface that can ensure simple and reliable operation.

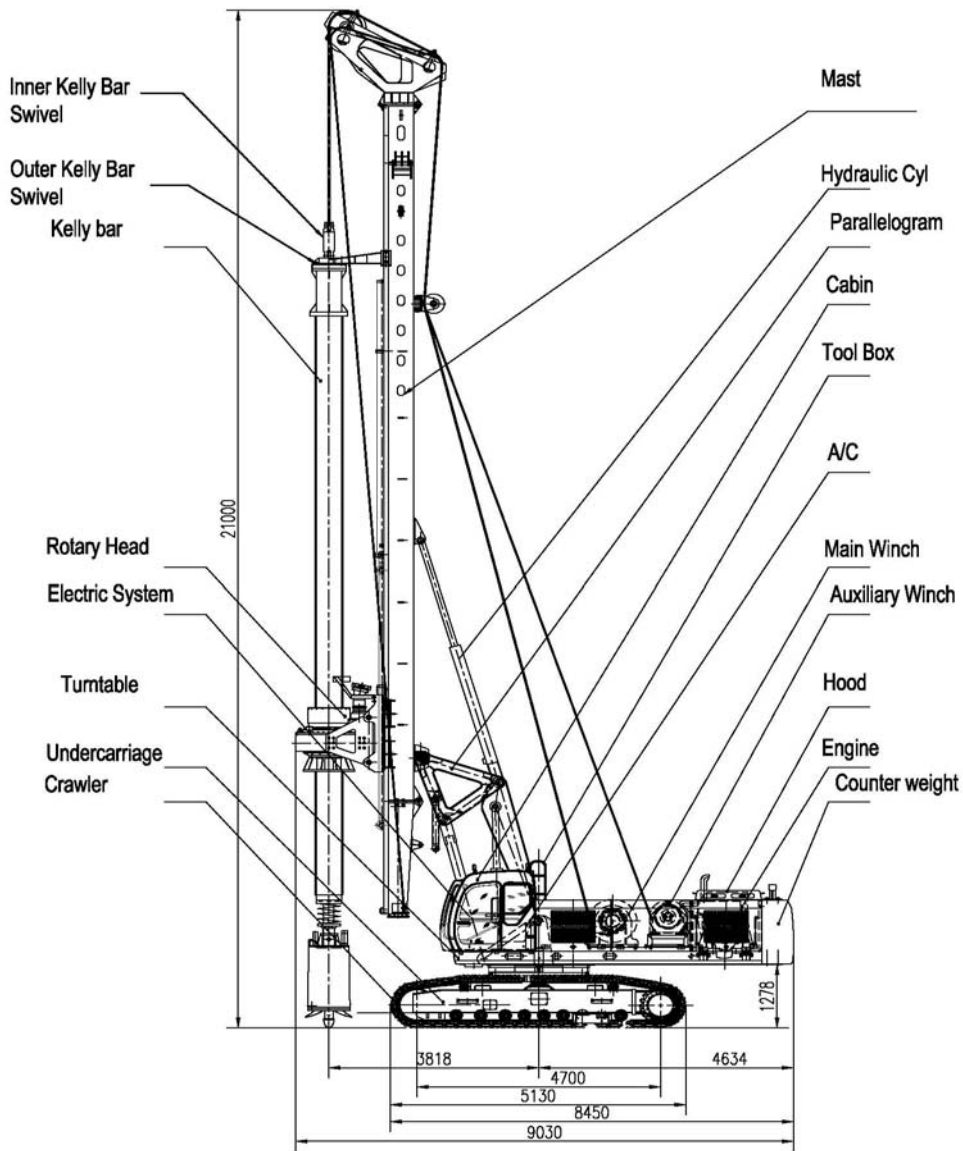
Automatic mast verticality adjustment and manual control of booming up; manual or automatic return after spinning off; automatic real-time drilling depth monitor; operation malfunction automatic recording; hole depth recording; signal input/output adjustment and inspection; mast L/R titling angle limitation; parallelogram system safety control; cooling system auto-start; main & auxiliary winch misoperation protection; moving and working operation interlocking and platform swing lock when drilling a hole.

§ 3 Technical Data

§ 3.1 Drill rig component and dimension

The structure of equipment, components and installation dimensions are shown in Figure 1 and Figure 2. The transportation dimension is shown in Figure 3.

Figure1



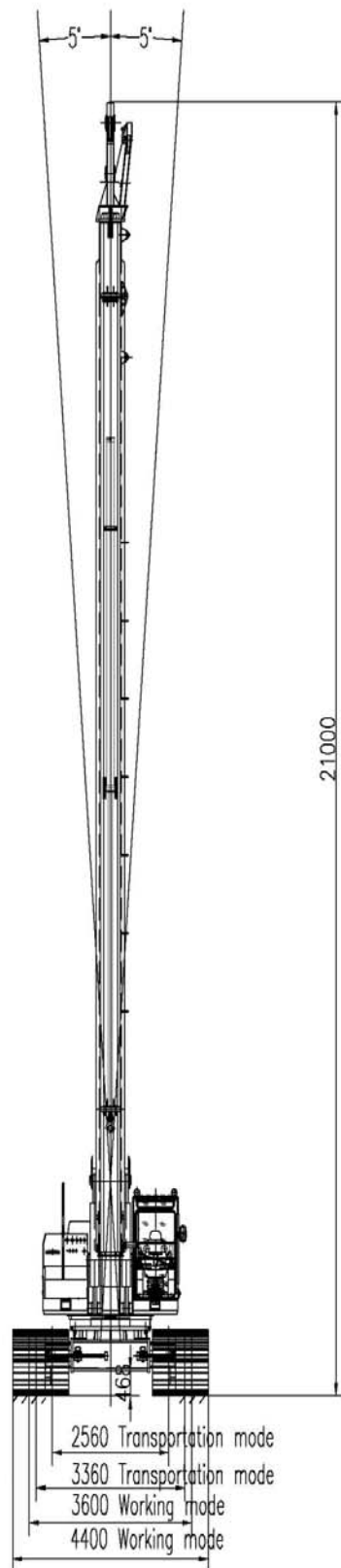


Figure 2

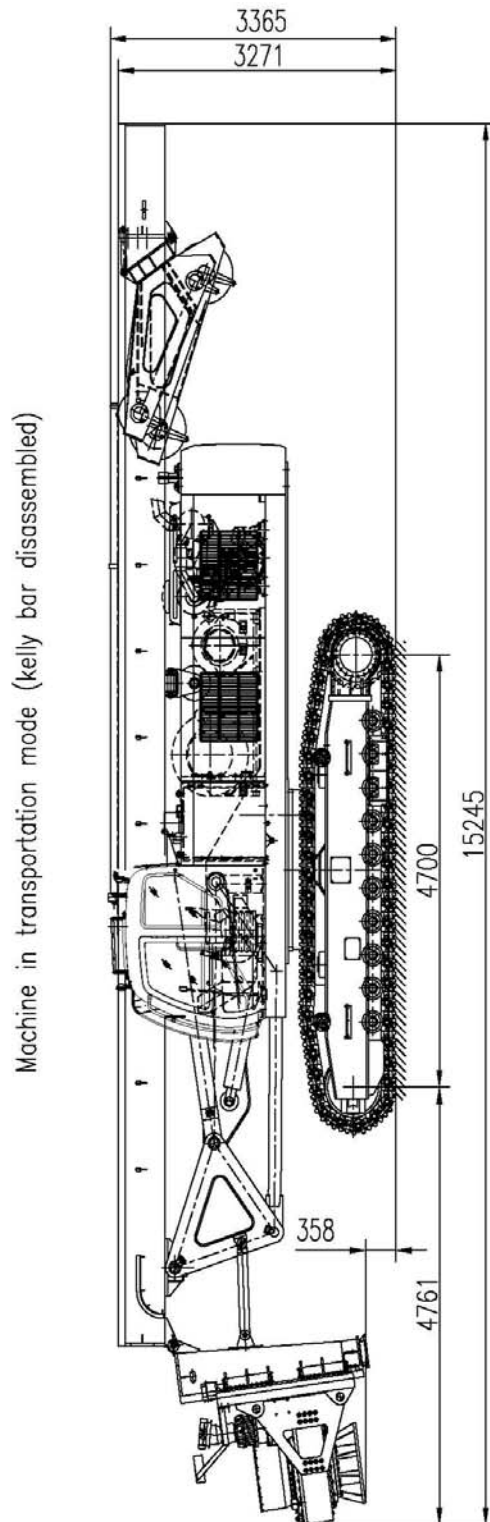


Figure 3

§3.2 Main technical data

Item		Parameter	
Max. drilling diameter	inch	Ø80 (mast to center of kelly bar)	
Max. drilling depth	ft	197(5 sections kelly bar) 157(4 sections kelly bar)	
Measurement	Working condition ft	29.6 x 14.4 x 68.9	
	Transportation condition ft	50 x 11 x 11	
Total weight (working condition)	lbs	154,324	
Engine	Model	M11-C330	
	Rated power hp/rpm	330/2100	
	Max. torque ft-lb/rpm	1075/1300	
Hydraulic system	Max. Working pressure psi	Main pump 4,351	Auxiliary pump 4,061
	Max. oil flow rate gal/min	2×55	24
Rotary Head	Max. torque ft-lb	147,512	
	Rev rpm	6~26	
	Max. Spin-off rate rpm	110	
Crowd cylinder	Max. crowd force push lbs	40,786	
	Max. crowd force pull lbs	46,297	
	Max. stroke ft	16.4	
Main winch	Max. line pull lbs	40,466	
	Max. line speed ft/min	240	
	Wire rope diameter inch	Ø1.125	
	Max. line pull lbs	17,985	

Auxiliary winch	Max. line speed ft/min	180
	Wire rope diameter inch	Ø0.81
Mast tilt	Left and Right Tilt Degree	±5
	Forward Tilt Degree	5
	Backward Tilt Degree	90
Turntable	Swing angle Degree	360
	Swing speed r/min	3
Undercarriage	Max. travel speed mph	2
	Max. travel slope	30%
	Min. ground clearance inch	18.4
	Width of track shoes inch	31.5
	Overall width of crawler (retract/extend) inch	101-142
	Overall length of crawler inch	185

§4 Main Structural Features and Working Theory

§4.1 Drilled Shaft Installation Procedure

§4.2 Structure and Basic Theory

Basic Function and Theory:

See Fig. 1 for drill rig structure. The house and undercarriage of the drill rig are interlocked. When in traveling mode, the hydraulic motors drive the traveling planetary and the crawlers move forward/backward, left/right and stop. Crawlers extend and retract, mast booms up/down. Crowd force is controlled by hydraulic cylinder. Kelly bar rotation, main/auxiliary winches and turntable utilizes planetary. The rotary head is equipped with hydraulic motors and planetary and the driving sleeve drives the kelly bar. The crowd cylinder is connected with the rotary head and the cylinder can generate the necessary compressive vertical force on the rotary head. Rotate to proper location to raise drilling tool for dumping.

Total drilling depth and depth of each pass are displayed in the virtual digital display and drilling procedure is stopped when designed tip elevation is reached.

Casing can be installed by mast foot or casing twister.

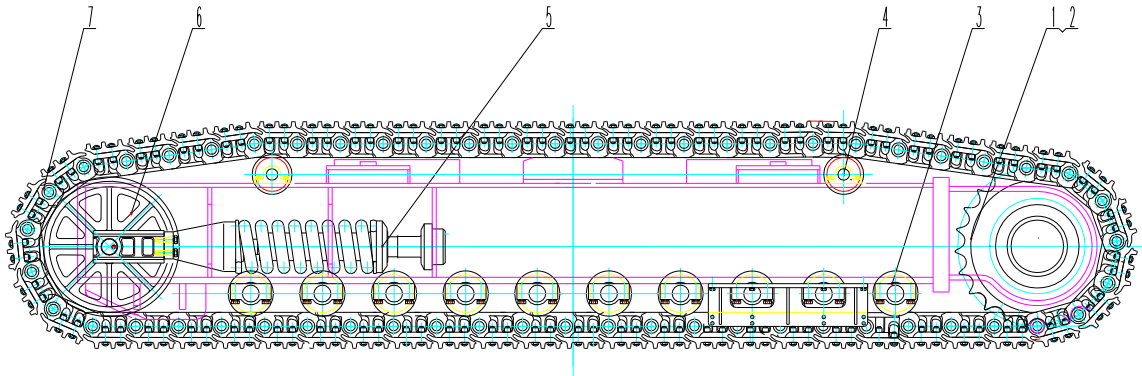
For transportation, the mast can be boomed down with kelly bar and kelly bar bracket detached. With the cathead and lower mast folded and crawlers retracted, the drill rig can move onto lowboy and the counterweight can be removed if road condition does not permit.

Main Structure

§4.2.1 Undercarriage

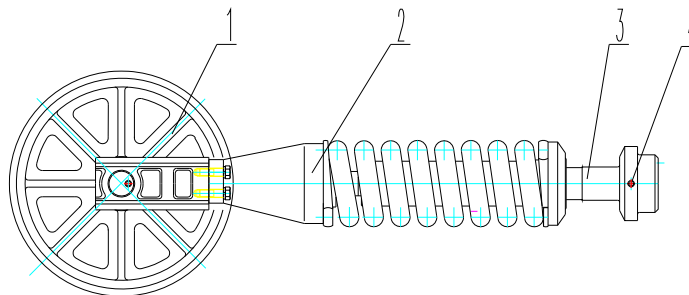
Undercarriage includes frame and traveling components. Frame is box structure and two main beams are controlled by hydraulic cylinder. Crawlers traveling mechanism (Fig. 5) includes planetary, sprocket, track roller, carrier roller, guide wheel, crawler assembly, tension unit (Fig. 6).

Crawler traveling mechanism (Fig. 5) is driven by sprocket, speed reducer and hydraulic pumps. Planetary (Model GFT80T3) is made by Rexroth equipped with constant-close, multi-plate brake system when it runs at high speed. The brake system works under tension spring when the drill rig is stopped, and the brake is released when traveling is engaged.



1. planetary 2. sprocket 3. track roller 4. carrier roller 5. tension unit
6. guide wheel 7. tracks assembly

Fig. 5 Crawler



1. guide wheel 2. tension spring 3. tension cylinder 4. grease zerk

Fig. 6 Tension Unit

Crawler tension unit (Fig. 6) is composed of tension cylinder, tension spring, guide wheel, oil cup. The function of tension unit is to keep enough tension on the crawlers during drilling or traveling. If the crawlers are too loose, use grease gun to fill grease through grease zerks and the guide wheel will shift outward and the crawlers will tighten.

§4.2.2 Turntable

Turntable is composed of rotating planetary, slewing bearing, rotating frame and mast support. Rotation is achieved by a slewing bearing driven by a planetary gear. Planetary (Model Rexroth GFB36T3) is three-speed, planetary gear box with constant-close, multi-plate brake. Slewing bearing is a single-row four point contact ball slewing ring.

§4.2.3 Drill Mast and Parallelogram System

The box type drill mast is composed of three sections. The upper cathead section and the lower drill mast section can be automatically folded or attached/detached (Fig. 7). Rotate the drill mast 90 degree and raise one side of the crawlers by pushing the lower drill mast down to extend or retract the crawlers (Fig. 8).

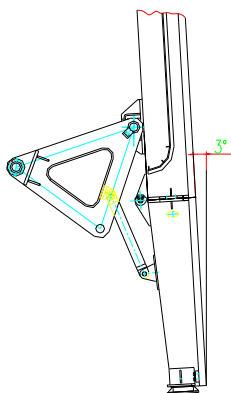
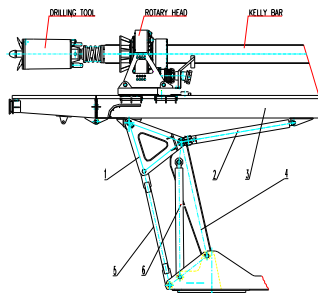


Fig. 7 Lower mast off from main mast



Fig. 8 Crawlers extend and retract

The parallelogram system is composed of arms, triangle frames and parallelogram cylinders (Fig. 9). The parallelogram cylinders control the angle of arms, the mast hydraulic cylinders control the main mast verticality. The main mast can tilt 5 degree left/right; 5 degree forward and 15 degree backward. Kelly bar must be vertical during drilling to prevent A-frame and kelly bar damage. **DRILLING WITH MAST MORE THAN 2% OUT OF PLUMB VOIDS ANY WARRANTY.**



1. Triangle Frame 2. Mast cylinder
3. Mast 4. Arms 5. Link Rod
6. Parallelogram cylinder

Fig. 9 Parallelogram System



Left: Main winch. Right: Aux. winch
Fig. 10 Main/Aux. winch

§4.2.4 Main/Aux. winches

The main/aux. winches are located on the turntable. The main winch is used for kelly bar and the aux. winch is used for assistance to drilling. The aux. winch is not to be used as a crane or to replace service crane. Winch planetary is made by Roxroth and the main winch has dual-speed control and free-fall control (Free-fall is not permitted if the drill rig is not in drilling status).

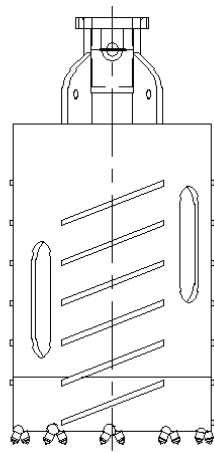
§4.2.5 Rotary Head

Rotary head is composed of bracket and driving components. The bracket supports the driving components and takes vertical force from the crowd cylinder. The driving components consist of two hydraulic motors, planetary, driving gear, gear box and driving sleeve. The working theory is that the driving sleeve drives the kelly bar to rotate after speed is reduced by driving gear and speed reducer.

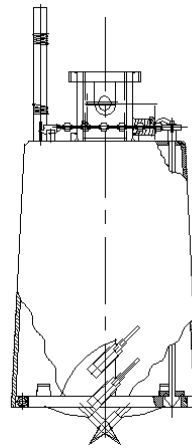


Fig. 11 Rotary Head

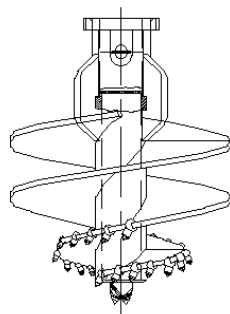
The first stage lubrication of the gear box adopts circulation lubrication and the second stage lubrication adopts oil-bath lubrication. Planetary runs in high speed by a small transmission ratio when spinning-off is required. The driving sleeve has rectangle teeth and rotates with the kelly bar when they are engaged. The control system is a variable pump, variable motor system and it can automatically adjust its speed and torque(power load sensing) according to different soil condition.



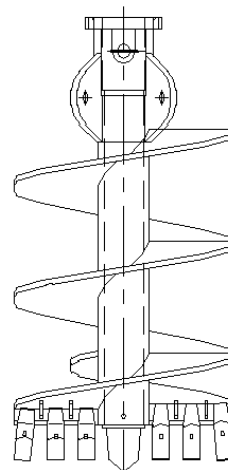
(a) Core barrel



(b) Drilling bucket



(c) Rock auger



(d) Dirt auger

Fig. 12 Drilling tool

§4.2.6 Kelly Bar, Drilling Tool

The outer kelly bar engages with rotary head and the top kelly is connected with kelly bracket which slides up/down on the mast guide. When the teeth disengage, each section of the kelly can freely extend and retract. The top inner kelly bar is connected to the wire rope by a swivel and the bottom square connects to the drilling tool. The kelly bar can be retracted (interlocking bar disengage) by main winch wire rope.

Common drilling tools (Fig. 12) and specification (Chart 2, 3, 4 & 5)

Table 2

Name	Hole Dia(mm)	Tool Dia(mm)	Pitch(mm)	High(mm)	Note
Rock auger	Φ500	Φ490	300	280	
	Φ600	Φ590	400	1030	
	Φ800	Φ790	400	1030	
	Φ1000	Φ990	500	1180	
	Φ1200	Φ1190	500	1180	
	Φ1500	Φ1490	500	1180	
	Φ1800	Φ1790	500	1180	
	Φ2000	Φ1990	500	1180	

Table 3

Name	Hole Dia(mm)	Tool Dia(mm)	High(mm)	Note
Drilling bucket	Φ600	Φ580	1702	
	Φ800	Φ780	1702	
	Φ1000	Φ980	1702	
	Φ1200	Φ1170	1702	
	Φ1500	Φ1470	1602	
	Φ1600	Φ1570	1602	
	Φ1800	Φ1770	1602	
	Φ2000	Φ1970	1602	

Table 4

Name	Hole Dia(mm)	Tool Dia(mm)	Pitch(mm)	High(mm)	Note
Dirt auger	Φ500	Φ480	350	1520	
	Φ600	Φ580	400	1520	

	Φ800	Φ780	400	1620	
	Φ1000	Φ970	500	1650	
	Φ1200	Φ1170	500	1550	
	Φ1500	Φ1470	600	1570	
	Φ1800	Φ1770	700	1770	
	Φ2000	Φ1970	700	1770	

Table 5

Name	Hole Dia(mm)	Tool Dia(mm)	High(mm)	Note
Core barrel	Φ500	Φ490	1150	
	Φ600	Φ580	1150	
	Φ800	Φ775	1150	
	Φ1000	Φ975	1150	
	Φ1200	Φ1175	1150	
	Φ1500	Φ1450	1150	

§4.2.7 Engine

CUMMINS M11-C330, 246kw/2100rpm (See engine manual)

§4.2.8 Hydraulic System

SA-20 main components- traveling, rotating, parallelogram, mast tilting, main/aux winch, rotary head are driven by hydraulic motors and cylinders (See hydraulic diagram Fig. 13).

The hydraulic system has two major parts-the turntable/undercarriage hydraulic system and upper hydraulic system.

Open hydraulic micro switch by lowering down the Left Console before operation and let pilot pressure oil flow into pilot control valves and solenoid valves.

(1) Undercarriage Hydraulic System

Traveling system and crawlers extend and retract:

1) Traveling system: working through an M8 Valve and L/R dual pedal pilot valve, two main pumps pump oil for two traveling motors which drive the drill rig

forward/backward and left/right.

2) Crawlers extend and retract: Switch on SA1 and solenoid valve Y34 works. Directional valve changes the pilot oil direction. Push Left Pedal forward/backward to extend/retract the right/left crawler while the right/left crawler is off the ground and the main drill mast is 90 degree relative to the right/left crawler.

(2) Upper-carriage Hydraulic System

Upper-carriage hydraulic system controls parallelogram, mast angle, crowd force down/up, main/aux. winches, upper structure swing, rotary head rotation (See Fig 14, 15 for joysticks, switches layout. Operation diagram see Table 6).

1) Parallelogram: Through M8 Valve, the main pump pumps oil to the parallelogram cylinders. Control pilot right joystick by pushing forward/pulling backward. The mast can horizontally move forward/backward.

2) Mast angle adjustment: Mast angle can be changed by controlling Electric Handle(with button SB7 pushed) (Attention: Left/Right tilting angle is less than 5 degree).

3) Crowd force down /up operation: Switch on SA10 and push right joystick forward or pull backward and the piston rod of hydraulic cylinder extends/retracts. If SA15 is switched on at the same time, the piston rod can quickly push downward/upward.

4) Rotary head: Switch on SA10, push right joystick left/right, the rotary head rotates counterclockwise/clockwise. If SB4 (or SB5) is switched on at the same time, high counterclockwise/clockwise spinning off speed is achieved.

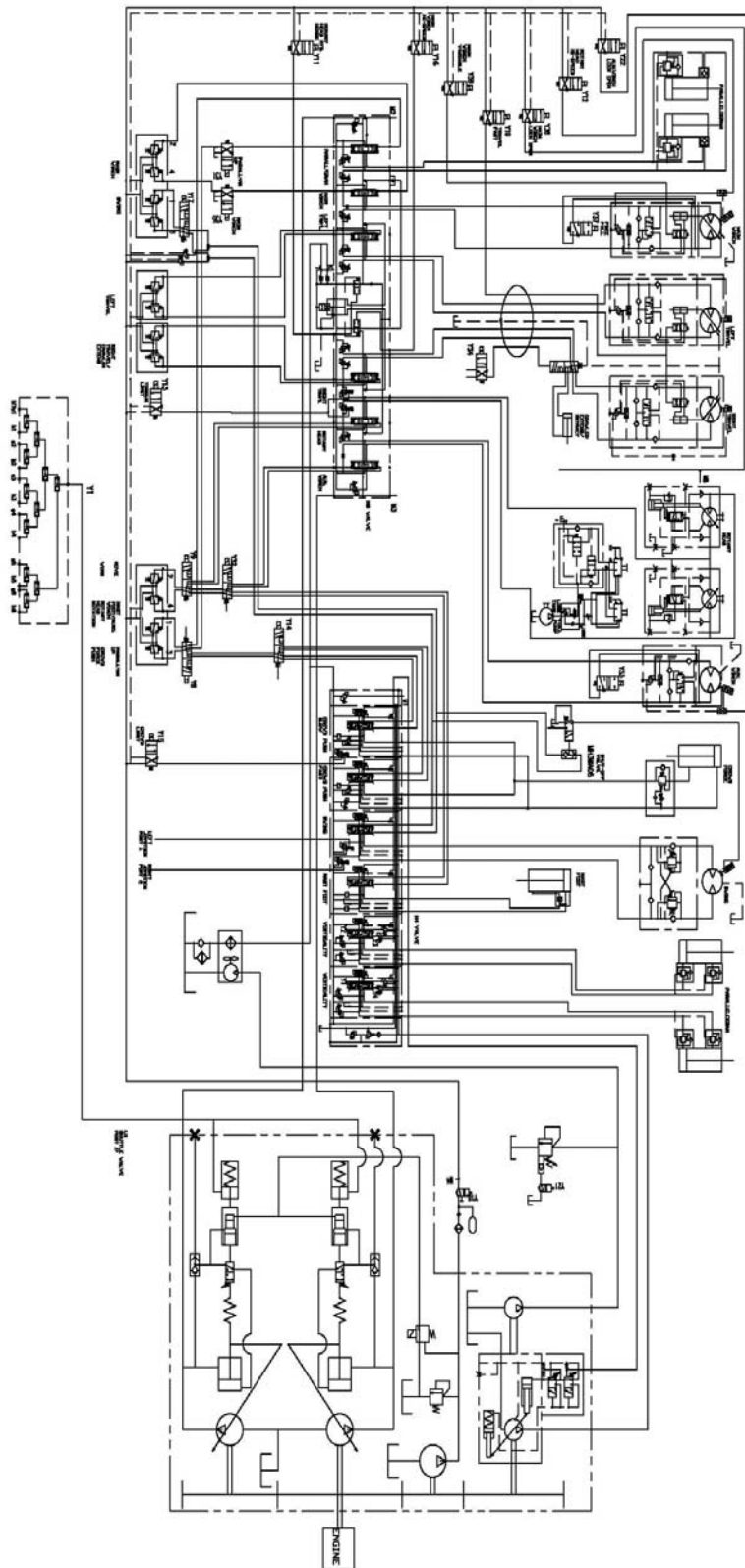


Fig.13 SA-20 Drill Rig Hydraulic Diagram



5) Superstructure swing: Push Left joystick left/right and the superstructure swings 360° counterclockwise/clockwise.

6) Main winch: Push Left joystick forward/backward to lower/lift load by the main winch. If SB1 (or SB2) is switched on, the main winch rope can quickly fall/lift.

7) Main winch free-fall: Switch SA11 on for main winch free-fall.

Attention : No kelly bar free-fall is permitted if the rig is not drilling.

8) Mast foot extension: Push SB5, push Right joystick left/right, the foot cylinder retracts/extends.

9) Aux. winch: Push right joystick left/right to lower/lift load.

10) Cooling System: Superstructure hydraulic system provides cooling for the whole drill

rig. Open SA8 to start the cooling pump (Fig. 13)

The hydraulic system has balance valves to prevent stall, buffering valve is for rotation buffering, pilot operated check valve locks the piston location of the hydraulic cylinder.

(3) Pilot Control System

The drill rig hydraulic system uses hydraulic pilot control. The micro switch under the left console controls the pilot oil passage.



Micro Switch

(4) Filters

The alarm will beep if oil filter is too dirty and filters need to be replaced. A high pressure oil filter is installed at the exit port of the pilot hydraulic pump to keep hydraulic oil clean.

Disabling this alarm voids any warranty.

(5) Hydraulic Oil

The drill rig uses YB-N68 hydraulic oil and hydraulic oil needs to be REPLACED every 1000 hours. When adding or replacing hydraulic oil, use the following grade:

IS04606 17/14-18/15 or NAS1638 Grade 8—9

§5 Electric System

Attention : !!! All the control units should be unplugged should any welding occur on the drill rig !!!

§5.1 Description

Electric system includes engine, controllers, control panels, sensors and display instruments. Equipped with advanced intelligent modules of CAN BUS programmable logic controller (PLC), graph guide display controller and engine maximum power-output-adjustment controller, the electric system becomes an intelligent control system with many functions of data collection, programmable control, virtual instruments display, BUS transmission and problem diagnosis. When pushbuttons are switched on, sensors check working parameters and limit parameters. PLC magnifies and calculates commanding signals, sensor signals to interlock or drive (motors, solenoid valves) so that operator can finish operations like monitoring engine, traveling, drilling, automatic leveling, automatic verticality of main mast, problem diagnosis and data saving. Hole depth display, drill rig working condition animation display, virtual instruments display are real-time shown on the monitor through CAN BUS transmission (Fig. 15).

§5.2 DESARS Intelligent Control System

DESARS Intelligent control system is a new generation of control system developed by Sunward Intelligent Machinery CO., Ltd. (Patent Registration Number: 2005SR05206). The system has functions of BUS transmission, automatic leveling, automatic swing, drill monitoring, system adjustment and setup, real-time monitor, data dynamic display, problem real-time diagnosis and operation and malfunction recording.

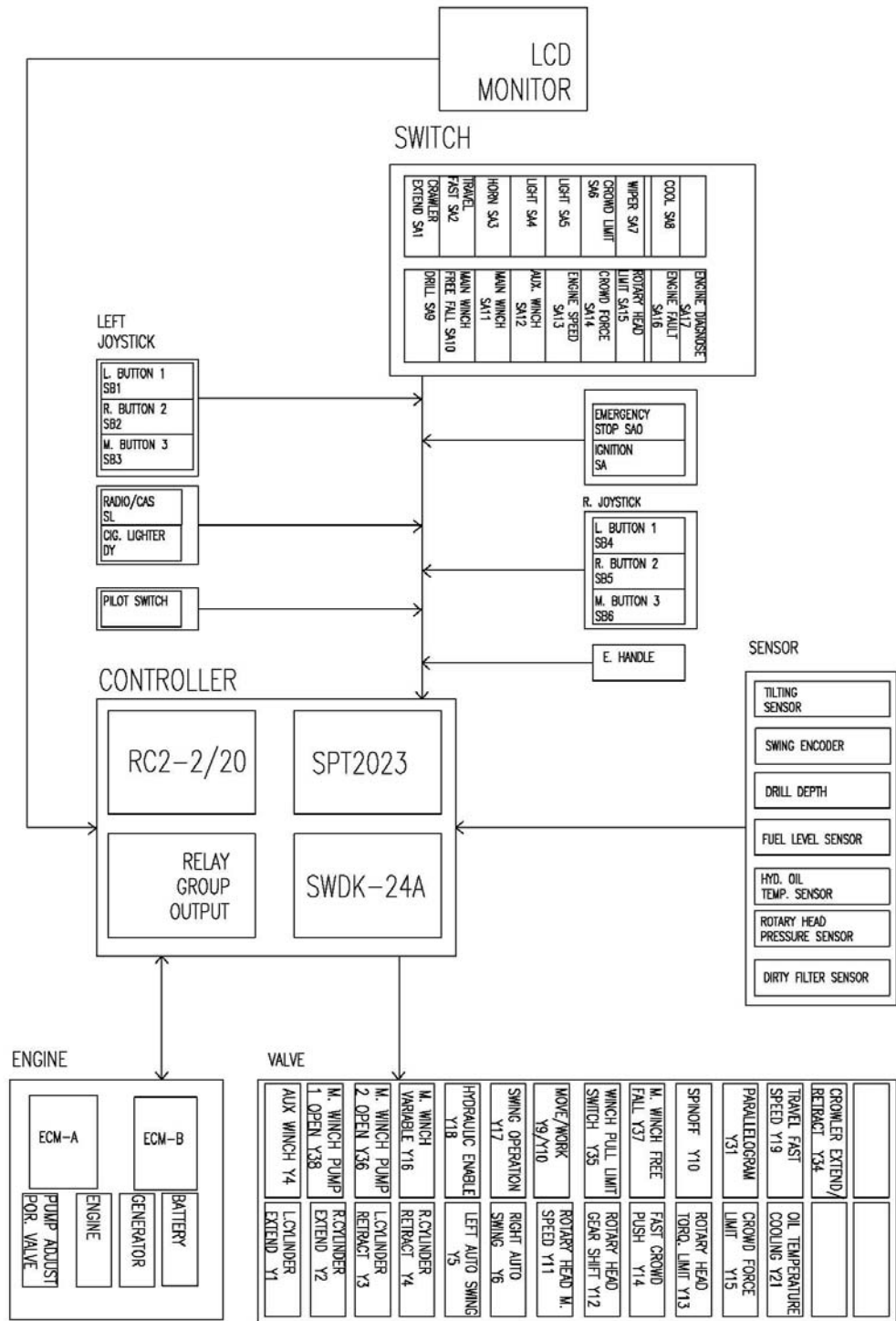


Fig. 15 SA-20 Electric System Layout

§5.2.1 Main Control Panel

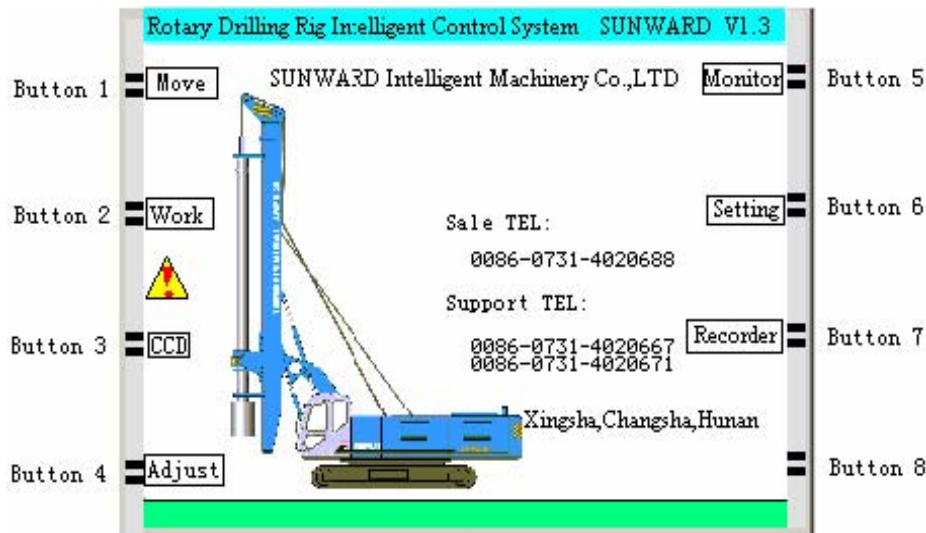


Fig. 16 Main Control Panel

Push “ MOVE ” button (Button 1): Boom up mast, leveling and swing(see5.2.2 Fig.17).

Push “ WORK ” button (Button 2): Monitor drilling process(see5.2.3 Fig.18).


Push “ CCD ” button (Button 3): Video monitor.

Push “ ADJUST ” button (Button 4): Hydraulic cylinders adjustment(see5.2.4 Fig.19).

Push “ MONITOR ” button (Button 5): Instruments and sensors monitor(see5.2.5 Fig.20).

Push “ SETTING ” button (Button 6): Setup new parameters (see5.2.6 Fig.26).

Push “ RECORDER ” button (Button 7): Drilling record (see 5.2.7. Fig. 27)

The blue bar on top of monitor displays the software version and the company name and the bottom green bar displays at which working condition the drill rig is. The sign  flashes when malfunction occurs. Push “MONITOR” button 5 to see where the problem is. Check engine if engine hydraulic oil pressure sensor beeps.

§5.2.2 Adjusting Control Panel

Push “ MOVE ” button (Button 1) to enter control panel (Fig.17).

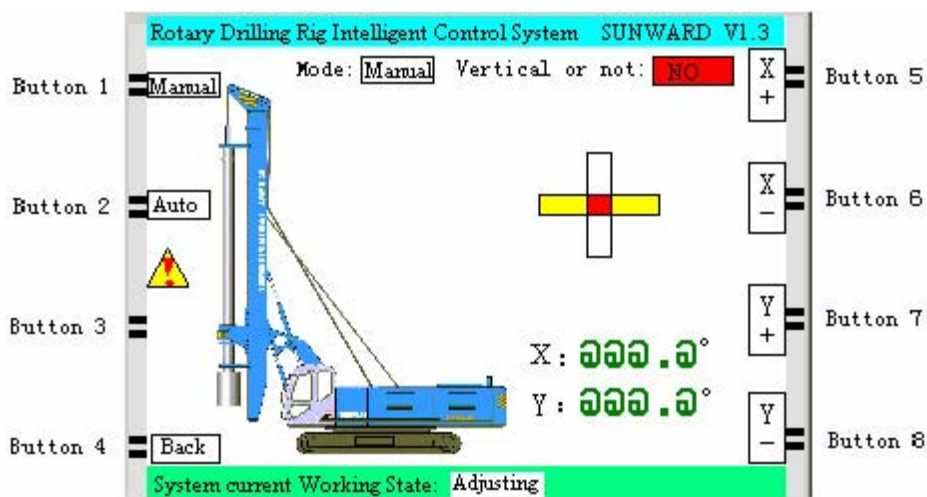


Fig. 17 Move/Adjust Control Panel

Current display is MANUAL mode. Push button 2 AUTO mode for auto leveling. Auto leveling fails if X and Y axes show 5° more and the display goes back to MANUAL mode again and LEVEL DISPLAY shows “UNEVEN”. If X and Y angles are less than 5°, auto leveling keeps the mast straight and LEVEL DISPLAY shows “EVEN”

Push Button 1 for MANUAL mode if needed.

Adjust X+ , X- , Y+ , Y- for kelly bar verticality.


Push “X +” (Button 5) to increase angle on X-direction (tilting right increase) ;

Push “X -” (Button 6) to decrease angle on X-direction (tilting left increase) ;

Push “Y +” (Button 7) to increase angle on Y-direction (tilting backward decrease) ;

Push “Y-” (Button 8) to decrease angle on Y-direction (tilting backward increase) .

Push Button 4 to EXIT.

Sign  flashes if malfunction occurs. Push “MONITOR (Button 5) for further details. LEVEL DISPLAY shows “EVEN” when X and Y are within 0.2° range otherwise the LEVEL DISPLAY shows “UNEVEN” (Fig. 17).

§5.2.3 Work Panel

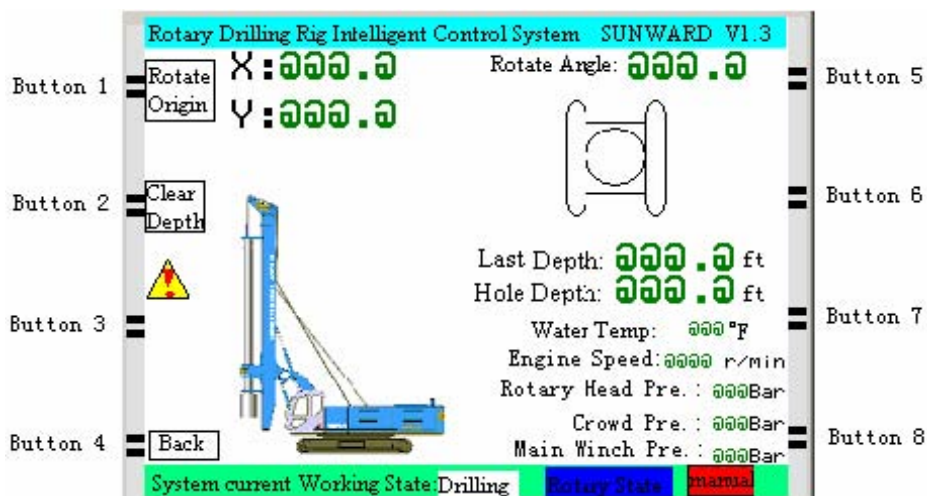



Fig. 18 Drill Control Panel

Push “WORK” (Button 2) from (Fig 16) Main Control Panel and the Main Control Panel becomes Fig. 18-Driling Panel which shows current kelly bar right tilting angle (X) and front tilting angle (Y), rotation angle, previous hole depth, current hole depth, water temperature, engine speed, rotary head pressure, crowd force, main winch pressure.

Push “ROTATE ORIGIN” (Button 1) and ROTATION ANGLE becomes zero. This function enables the drill rig to return to its original location after spinning off. The rotation angle is controlled within a range of 0.1 degree.

Push “CLEAR DEPTH” (Button 2) and set current hole depth to zero after drill tool is set on ground.

“FREE FALL” appears on the right corner when kelly bar depth reaches to previous drill depth.

Sign  flashes when malfunction occurs. Push “MONITOR” (button 5) to check further details. Push “EXIT” (button 4) to go back to Main Control Panel.

§5.2.4 Adjust Panel

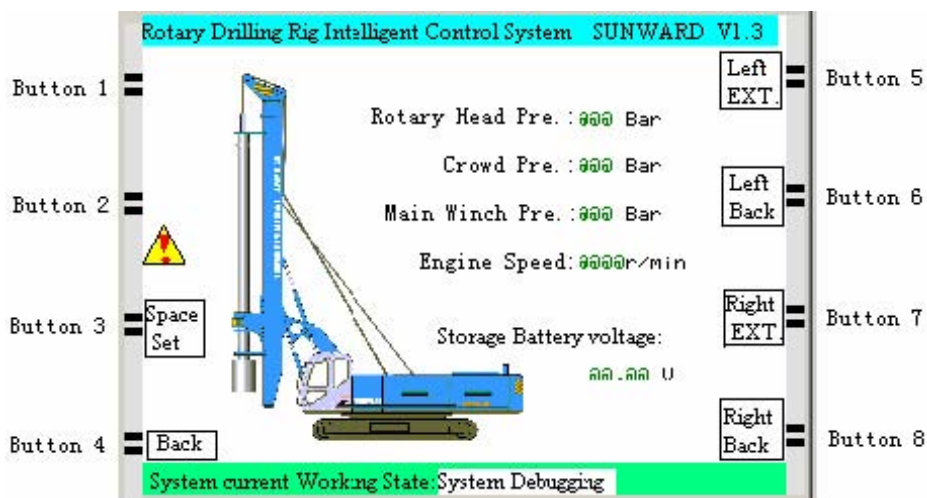


Fig. 19 Adjust Panel

Push “Adjust” (Fig. 16 Main Control Panel) (Button 4)to enter Fig. 19 Adjust Panel and the real-time display shows rotary head pressure, crowd force pressure, main winch hoist pressure and engine speed. The main function of this mode is to manually adjust the verticality of the mast.

Push “Button 5” to extend left cylinder of the drill mast;


Push “Button 6” to retract the left cylinder of the drill mast;

Push “Button 7” to extend right cylinder of the drill mast;

Push “Button 8” to retract the right cylinder of the drill mast.

Push “SPACE SET” (Button 3) for space setting up.

Push “EXIT” (Button 4) to exit to main control panel.

Sign  flashes when malfunction occurs. Push “MONITOR” (button 5) to check further details. If during drilling procedure hole becomes more than 2 degree out of plumb and operator tries to correct by manually changing mast or proceeds beyond 2 degree verticality in hole it may result in kelly bar damage.

§5.2.5 Monitor Panel

§5.2.5.1 Instrument Monitor Panel

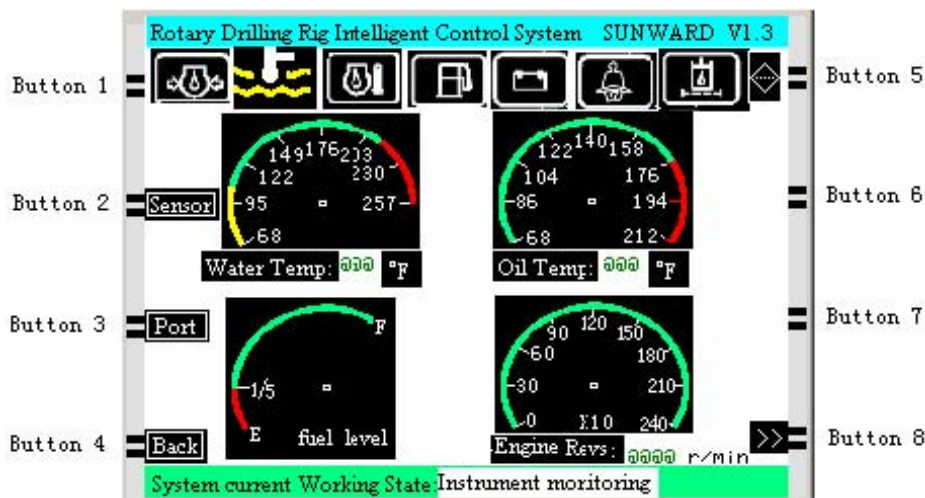


Fig. 20 Monitor Panel-1

Push “Button 5” on the Main Control Panel (Fig. 16) to enter to Monitor Panel-1(Fig. 20).

Alarm icon Fig. 21 :



Fig. 21 Alarm Indicating Icon

Icon 1: Engine fault alarm;

Icon 2: Coolant temperature alarm;

Icon 3: Hydraulic oil temperature alarm;

Icon 4: Fuel level alarm;

Icon 5: Charge battery alarm (Low battery alarm);

Icon 6: Main winch limitation alarm;

Icon 7: Hydraulic enable signal;

Icon 8: Hydraulic oil filter plugged alarm.

Icon flashes and changes to red color if safe parameter is out of range.

Hydraulic Pilot Handle(Safety Handle): When the left console is lowered and the micro switch is on, the Incon 7 should be red alerting the operator that the rig is in operation mode.

Virtual instrument displays water temperature, hydraulic oil temperature, fuel level, and

engine rpm. Green zone is safe zone and red zone is critical zone. Wait and slow down until water temperature reaches to safe zone before normal drilling if water temperature indicator is in the yellow zone.

Push “>>” (Button 8) to enter next page (Fig. 22 Monitor Panel-2);

Push “SENSOR” (Button 2) to enter SENSOR diagnosis panel (Fig. 25);

Push “PORT” (Button 3) to enter port check panel;

Push “EXIT” (Button 4) to go back to Main Control Panel.

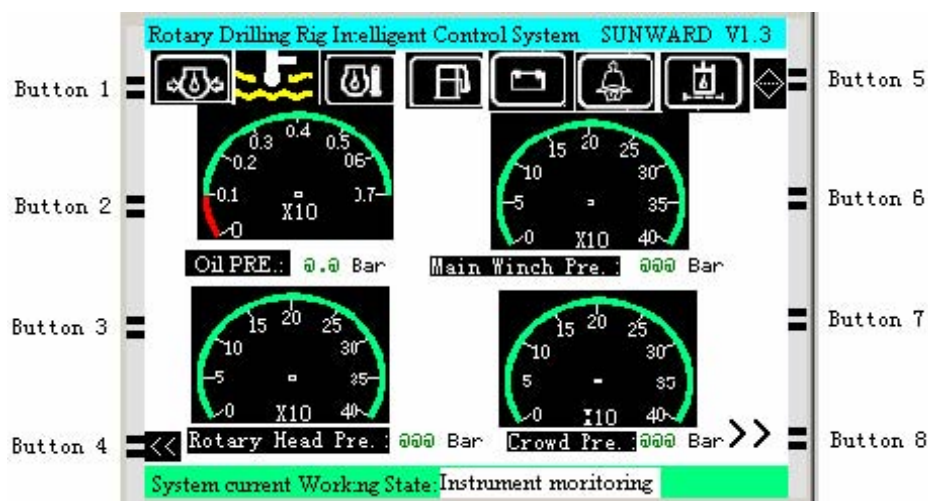


Fig. 22 Monitor Panel-2

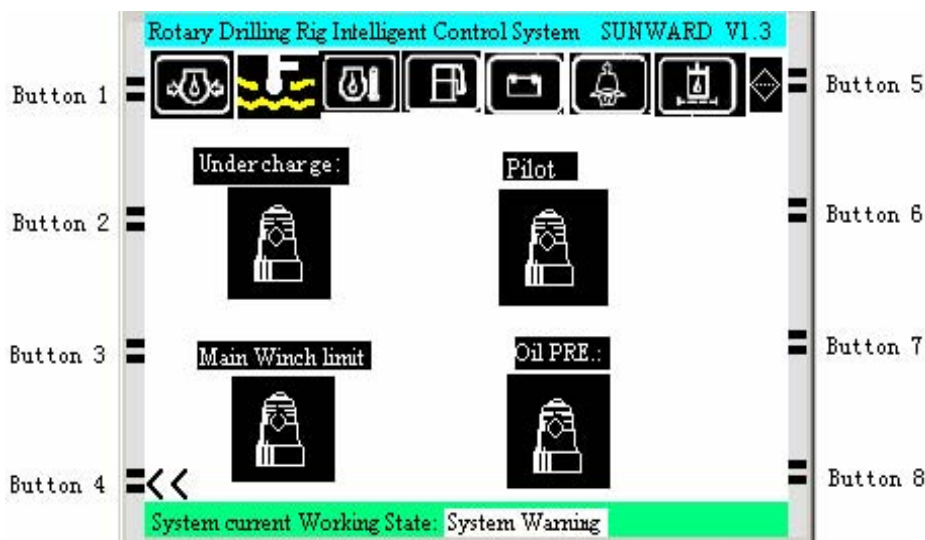


Fig. 23 System Alarm Panel

Push “<<<” (Button 4 Fig. 23) to go back Monitor Panel-2 (Fig. 22).

Alarm icon turns red, flashes and beeps when parameter is out of range (Fig. 24).



Fig. 24 Alarm

§5.2.5.2 Sensor Malfunction Panel

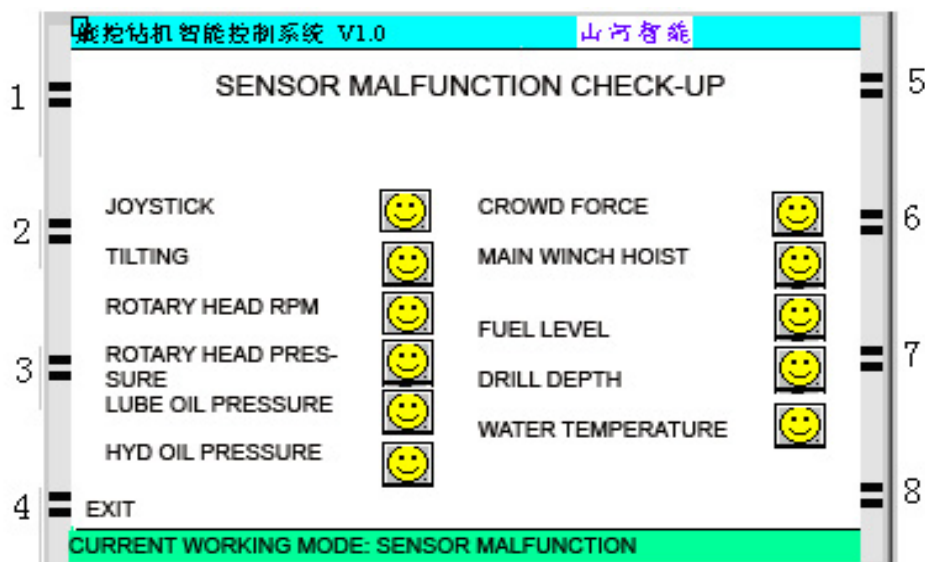




Fig. 25 Sensor Malfunction Panel

Push “SENSOR: (Button 2 Fig. 20) to enter Fig. 25 Malfunction Sensor Panel. When icon  turns to , it indicates malfunction on the sensors and these sensors need to be replaced.

Push “EXIT” (Button 4) to exit and return to Fig. 20 Monitor Panel-1

§5.2.6 Setup Panel

Push “SETUP” (Button 6) in Main Control Panel (Fig. 16) and input password (Fig. 26).

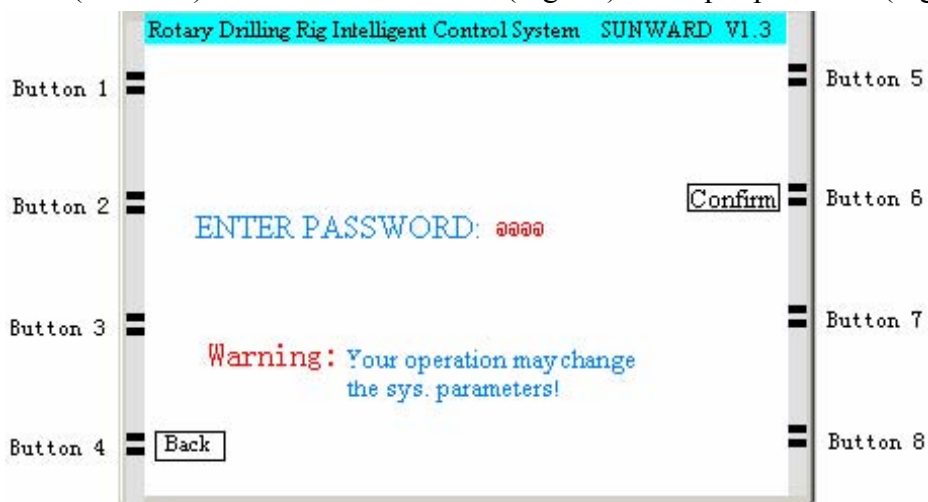


Fig. 26 Setup Confirm Panel

Special Note: Changing “SETUP” will change system parameter and system setup. Any inappropriate setup would affect the performance of the drill rig or may cause operation out of control thus lead to accident. Therefore, SETUP should be carried out under the supervision of our technician otherwise we are not responsible for any consequences caused.

§5.2.7 Recording Panel

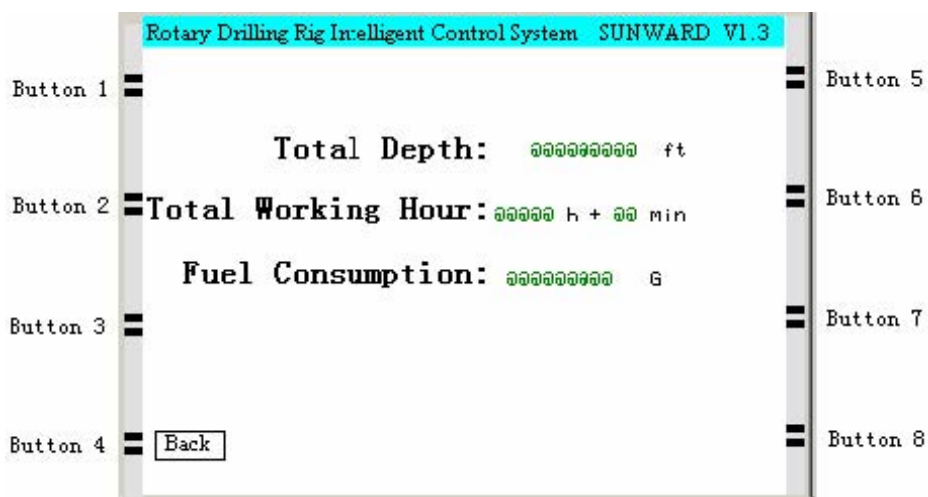


Fig. 27 Recording Panel

Push “RECORDER” (Button 7 Fig. 16) to enter to RECORDING PANEL (Fig. 27).

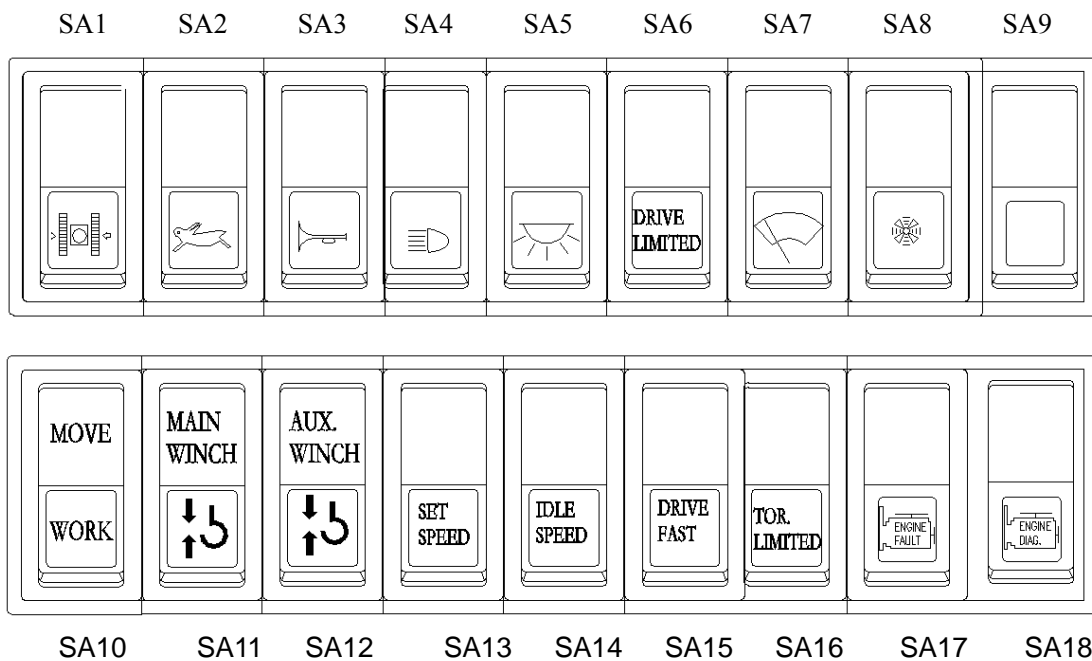
It records the total drill depth (unit: meter) and total working hours. When the total drill depth exceeds 32,766 meters, the display will use 32,767 + Xm to show the accumulative drill depth.

Push “EXIT” (Button 4) to go back to Main Control Panel.

§5.3 Control, operation of Engine and Auxiliary Appliances


§5.3.1 Main Power Open and Auxiliary Appliances Control

The main power is controlled by SA Key switch. When the key is turned to the first slot, the main power is on and the followings can be completed:



- 1) Push “SA1” for crawler extend/retract;
- 2) Push “SA2” for fast travel;
- 3) Push “SA3” for horn;
- 4) Push “SA4” for headlights;
- 5) Push “SA5” for cabin light;
- 6) Push “SA6” for crowd force limit;

- 7) Push “SA7” for wiper;
- 8) Push “SA8” for hydraulic cooling system(when hyd. oil is at 150⁰ F)
- 9) Push “SA9” for WARNING light;
- 10) Push “SA10” for MOVE/WORK;
- 11) Push “SA11” for main winch free fall;
- 12) Push “SA12” for aux. winch free fall;
- 13) Push “SA13” to set engine speed(engine default speed is at 1600rpm);
- 14) Push “SA14” for idle speed. When joysticks are at neutral position and the rig is not working, four seconds after the button pushed , engine speed automatically drops to 1200rpm;
- 15) Push “SA15” for crowd force push fast;
- 16) Push “SA16” for rotary head torque limit;
- 17) “SA17” for Engine Fault (for idle speed adjust: push top, idle speed is increased by 30r; push bottom, idle speed is decreased by 30r. This switch is also used as page turnover for engine malfunction when engine is shut down and SA17 is switched on)
- 18) “SA18” for engine diagnose.

In case the Orange Light on the Right Console is on , the engine malfunction can be diagnosed by pushing open SA18  . Simply by counting

how many times the Red Light flashes after SA18 is on, engine error code can be found. Follow the steps below to diagnose engine error:

- (1), Push down SA18 when the Orange Light is on;



(2), Write down how many times the Red Light flashes, if the light flashes 1 time, write down 1;

(3), There should be one second pause between the first and the second time flash;

(4), Count how many times it flashes, if the light flashes 5 times, write down 5;

(5), Then there will be another one second pause;

(6), Count how many times it flashes, if the light flashes 3 times, write down 3;

So the error code of the engine is 153. Check the error code chart on §5.5 to find the engine problem.

§5.3.2 Engine Start-up

Check oil, coolant before engine start-up; insert ignition key and turn the key to the first slot position; then change the display to Monitor Panel-1 to check virtual gauges and warning lights; continue turn the key to the second slot position to start the engine(Do not engage starter for more than 10 seconds).

§5.3.3 Engine Shut-down

Switch off the micro switch by lifting the left console before engine shut-down. Let the engine run for a short period of time to eliminate excessive heat and turn the key to ‘OFF’ position to shut down the engine.

§5.4 Control During Drilling Process

In order to have a friendly working interface and safe working interlock, the drill rig has adopted two processes-drilling and moving. All the hydraulic system is enabled and hydraulic

pilot lines are pressurized only after hydraulic micro switch is pushed on.

§5.4 .1 Drill Rig Move Mode

Move mode includes: drill rig traveling; drill mast lower foot

extend and retract; crawlers extend and retract; main/aux



Fig. 28

winch; parallelogram; upper carriage manual/auto rotating and mast automatic boom up.

After engine start-up, push down the Left Console, the right Emergency Stop Button off;

Set SA10 Button(MOVE/WORK) to MOVE (Fig. 28) and the drill rig is ready to move.

§5.4.2 Drill Rig WORK Mode












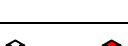






WORK Mode includes: main/auxiliary winches operation; rotary head operation; upper carriage rotation and crowd force.


After engine start-up, push down the Left Console; the right Emergency Stop Button off;









set SA9 Button(MOVE/WORK) to WORK (Fig. 28) and the drill rig is ready to drill.

See Table 6 for drill rig MOVE/WORK joystick/pedal operation:

Table 6



SA9 ON MOVE	Left Joystick (SB1 SB2 SB3)		Main winch down		
			Main winch up		
			Upper-carriage left swing		
			Upper-carriage right swing		
		Push SB3	Auto swing to original position		
	Right Joystick (SB4 SB5 SB6)		+SB4	Parallelogram down	
			Parallelogram up		
				Aux. winch down	
			+SB5	Mast foot retract	
				Aux. winch up	
			+SB5	Mast foot extend	
	Pedal		Drill rig moves forward		
			Drill rig moves backward		
			Drill rig turn right		
			Drill rig turn left		
		Open SA1 	left pedal 	Crawler extend	
			left pedal 	Crawler retract	
	Electric Handle (push SB7)		Mast boom up/ mast forward tilting		
			Mast boom down/mast backward tilting		
			Mast left tilting		



			Mast right tilting
--	--	---	--------------------

SA9 ON WORK	Left Joystick (B1 SB2 SB3)		Main winch down	
			+SB1	Main winch down, merge (mid-speed)(Push SB1 first)
			+SB2	Main winch variable + main winch down + merge (hi-speed)(Push SB2 first)
			Main winch up	
			+SB1	Main winch up, merge (mid-speed)(Push SB1 first)
			+SB2	Main winch variable +merge, winch up(hi-speed) (Push SB2 first)
			Upper-carriage Left swing	
		Upper-carriage Right swing		
	SB3	Auto swing to original position		
	Right Joystick SB4 SB5 SB6)		Crowd force push/ Hyd. Cyl. extend	
			Crowd force lift/Hyd. Cyl. retract	
			Rotary head clockwise rotation	
			+SB4	Rotary head merge (mid-speed)(Push SB4 first)
			+SB5	Rotary head merge + gear shift (hi-speed)(Push SB5 first)
			+SB6	Auto spin-off
			Rotary head anticlockwise rotation	
			+SB4	Spin-off (Push SB4 first)
			+SB5	Rotary head merge + gear shift (hi-speed)(Push SB5 first)

§5.4.3 Other Operation Control

1) When hydraulic oil reaches to 65°C, open SA8  to keep oil temperature not exceeding 85°C.

2) During drilling process, open SA11  for kelly bar free fall; open SA12  for auxiliary winch free fall

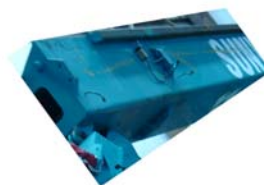
3) When soil condition is complicated, slows down drilling speed, open torque limitation switch SA16  and crowd force limitation switch SA6  to protect rotary head and kelly bar.

4) In case of emergency and people or equipment are in danger, push down Emergency Stop Button to stop all hydraulics.

§5.4.4 Interlocking and Safe Protection

For the safety of people and drill rig, the following interlocking and safe protection steps have been taken:

- a) Main winch pull-up limitation: in order to protect cathead from being hit by kelly bar when main winch pulls up, a limit switch is activated when kelly bar reaches to the top and the main winch can only descend and not ascend.



Following those steps to bypass limit switch:

Switch MOVE/WORK to MOVE, pull Left Joystick back, with both SB1 and SB2 buttons pushed, now the main winch can pull the kelly bar over the limit switch.

USE THIS OPERATION WITH CAUTION.

- b) Swing Limitation: when drill rig is in drilling operation and drilling depth reading is greater than zero, the system considers that the kelly bar is inside hole and accidents

may occur if upper-carriage swings and the program restricts this operation.

Upper-carriage can swing only drilling depth reading is less than -20cm(-0.8 inch). If the drilling depth proximity switch is damaged and the drilling depth reading is less than zero, switch the SA10 to MOVE for upper carriage Left/Right swing.

- c) Tilting limitation: Leveling drill rig before booming up mast and set MOVE/WORK (SA10) to MOVE. When left and right of mast deflection is over 5 degree, use Electric Handle for mast tilting; when mast's X and Y axles are within the range of ± 5 degree, use Auto Leveling.
- d) Spin-off limitation: when drill rig is in drilling operation and drilling depth reading is greater than zero, the system considers that the kelly bar is inside hole and spin-off is restricted. Spin-off works only the drilling depth reading is less than -20cm(-0.8 inch).
- e) In case of emergency and people or equipment are in danger, push down Emergency Stop Button to stop all hydraulics.



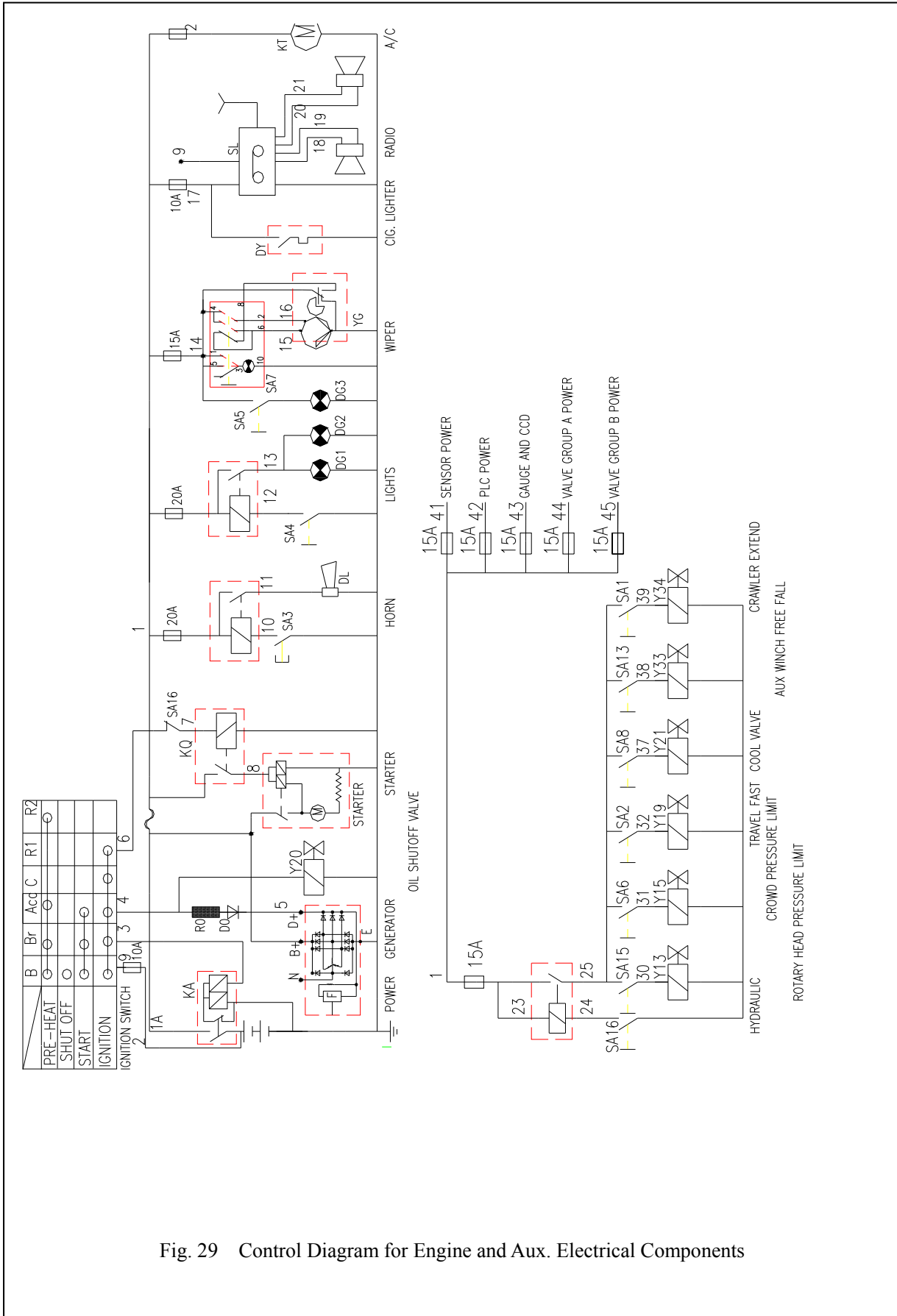
Emergency Stop

§§5.5 Engine Malfunction Indication and Error Code Chart

Table 2 (Y=yellow R=red W=white)

Error Code Light	SPN FMI	Description
111/Y	629/12	Engine control module internal error
115/Y	190/2	Engine speed/location sensors signals lost
122/Y	102/3	Air intake pipe pressure sensor circuit---hi-voltage short circuit
123/Y	102/4	Air intake pipe pressure sensor circuit---low-voltage short circuit
131/Y	091/3	Throttle pedal sensor circuit---hi-voltage short circuit
132/Y	091/4	Throttle pedal sensor circuit---hi-voltage short circuit
133/Y	029/3	Remote throttle pedal sensor circuit---hi-voltage short circuit
134/Y	029/4	Remote throttle pedal sensor circuit---hi-voltage short circuit
135/Y	100/3	Engine oil pressure sensor---hi-voltage short circuit
141/Y	100/4	Engine oil pressure sensor---low-voltage short circuit
143/Y	100/1	Engine oil pressure low
144/Y	110/3	Engine coolant temp.sensor---hi-voltage short circuit
145/Y	110/4	Engine coolant temp.sensor---hi-voltage short circuit
146/Y	110/0	Engine coolant temperature low
151/R	110/0	Engine coolant temperature high
153/Y	105/3	Air intake pipe temp. sensor circuit---hi-voltage short circuit
154/Y	105/4	Air intake pipe temp. sensor circuit---low-voltage short circuit
155/R	105/0	Air intake pipe temperature high
191	876/11	A/C clutch short circuit
234/R	190/0	Engine speed too high
235/W	111/1	Engine coolant too low
241/Y	084/2	Speed sensor signal lost
242/Y	084/10	Error in speed sensor signal
243	513/4	Error in brake delay signal--42
245	647/4	Error in fan clutch delay signal---31
261/Y	174/0	Fuel temperature too high

264/Y	174/2	Fuel temp. sensor circuit---hi/low-voltage short circuit
278/Y	1075/11	Error in pump signal ---11
283/Y	636/3	Engine speed sensor circuit---hi-voltage short circuit
284/Y	636/4	Engine speed sensor circuit---hi-voltage short circuit
297/Y	1084/3	Aux. pressure sensor signal input circuit---hi-voltage short circuit
298/Y	1084/4	Aux. pressure sensor signal input circuit---hi-voltage short circuit
319/W	251/2	Actual clock signal broken
349/Y	191/0	Gear box speed output too high
352/Y	620/4	Wire 10 voltage too low
361/R	1076/3	Fuel pump current too high
362/Y	1076/4	Fuel pump voltage too low
363/Y	1076/7	No fuel in fuel tank
364/Y	1077/9	No connection between ECM and fuel pump
365/Y	1077/4	Fuel pump control circuit---low voltage short circuit
366/Y	1077/2	Fuel pump power supply 6-24VDC
367/R	1078/11	Fuel pump location sensor signal lost
368/Y	1078/8	Fuel pump in delay receiving signal
369/Y	1078/2	Fuel pump can't detect pulse signal
372/Y	1077/11	Fuel pump detects continuous signal from idle speed switch
373/R	1077/3	Fuel pump control circuit—hi voltage short circuit
374/Y	1077/12	Fuel pump error
375/Y	629/2	Fuel pump actuator-drill rig plugged
376/R	1077/13	Fuel pump module not adjusted
377/Y	1077/7	Fuel pump module not connected
381/Y	626/11	Error signal in preheat relay---wire 41
382/Y	626/11	Error signal in preheat relay---wire 31
385/Y	620/3	Remote throttle sensor+5VDC too high
386/Y	620/3	Engine speed sensor+5VDC too high
387/Y	091/3	Throttle location sensor+5VDC too high
391/Y	632/11	Fuel pump wire43 signal error
415/R	100/1	Engine oil pressure too low
418	097/0	H ₂ O in fuel



§§6 Operation

§6.1 Preparation and Check-up Before Operation

- (1) Choose different drilling tool based on different soil condition.
- (2) Check hydraulic oil, no oil leakage.
- (3) Check Fuel.
- (4) Check wire rope.
- (5) Check tools.
- (6) Check bolts and nuts.
- (7) Check joysticks, levers and gauges.
- (8) Check engine coolant (see engine operation manual).

§6.2 Operation and Gauges

See Fig. 14 to 15 for names and codes of operational instrument in the cabin; see Fig. 16 to 28 for LCD display of working modes and switches.

Pressure gauges

You can also monitor the system maximum pressures by checking on the three gauges:



Gauge 1

Gauge 2

Gauge3

Gauge 1:

Parallelogram up/down = 300 bars

Main winch = 300 bars

Left travel = 280 bars

Gauge 2:

- Crowd force pull = 280 bars
- Crowd force push = 120 bars
- Mast up/down = 280 bars
- Mast foot retract = 280 bars
- Swing = 240 bars

Gauge 3:

- Rotary head = 300 bars
- Aux. winch = 240 bars
- Right Travel = 280 bars

§6.3 Operation

- (1) Open Main Power SA switch and start engine (see engine manual)
- (2) Move fuel control lever to “Mid” position.
- (3) Run engine at low rpm for 5 minutes after engine start-up.
- (4) Stop engine if engine oil icon becomes red. Check engine and begin operation after everything is normal.

§6.3.1 Drill Rig Positioning

Open Main Power SA switch; open hydraulic switch by lowering down the Left Console; step on pedals. Step on both pedals for drill rig forward/backward. Step on left pedal, drill rig turns right, step on right pedal, drill rig turns left (see Table 6 for details).

Attention for operator when drill rig is travelling:

- 1 . Pin down undercarriage and turntable(pin is under driver’s right foot) and pull pin out when drill rig is in drilling process;
- 2 . Mast must be boomed down;
- 3 . Lock crawler extend/retract cylinder.

§6.3.2 Rig up

1. Mast self rigging/derigging

- 1) Reconnect coupling if crowd cylinder is disconnected or not loaded
- 2) Use rope to pull top folded top mast straight and bolt together with main mast; use crane or use rope to connect crowd cylinder (extend) to pull cathead.
- 3) Pull right joystick backward and the arm cylinder will extend; push Electric Handle (with SB7 pushed) forward and the parallelogram cylinders extend; use joystick and Electric Handle alternatively until mast is completely boomed up. Do not let mast touch ground during booming up. Feeding out main/aux. winch cables as mast and parallelogram go up. Stop electric handle operation when the lower mast and main mast are fully connected (otherwise components may be damaged). Take off the link rod between the triangle frame and lower mast.
- 4) Open switch SA9 to WORK, push right joystick forward and the crowd cylinder extends (push SA14 for quick cylinder action); continue pushing until cylinder is completely extended and ready for rotary head connection.
- 5) Take off the stopper plate under the sliding frame of the rotary head and move it to the bottom of the mast; push crowd cylinder to push rotary head downward; connect lower mast with main mast.

Mast derigging process is vice versa to the process above.

Special Attention:

- 1) **A helper is required during mast rigging/derigging.**
- 2) **Use proper length of wire rope during the mast rigging/derigging process. No wire rope overlapping is permitted to happen in the main/aux winches.**

2 . Crawler Extend/Retract

Attention : For the safety and stability of the drill rig, the crawlers must be fully extended before drilling operation.

Crawler extend: Choose a firm, flat ground; push Left Joystick left(or right) to swing uppercarriage left (or right) 90 degree; push Right Joystick forward and the parallelogram bows down until drill mast is in contact with the ground; put a piece of wood or steel plate

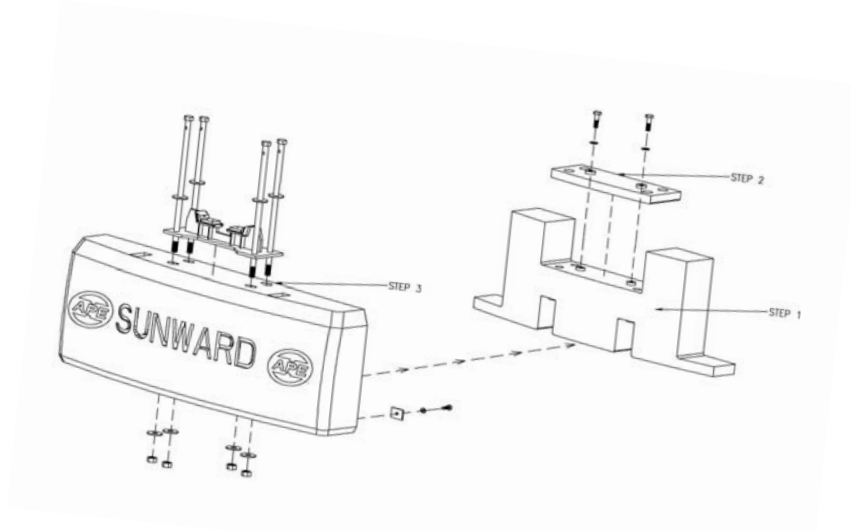
under the drill mast if the ground is not firm enough.

Push Right Joystick right (with SB5 pushed) to extend mast foot cylinder until left(right) crawler is raised; take off crawler pin; Push Left pedal forward until crawler(s) is fully extended.

Crawler retract is vice versa to the process above.

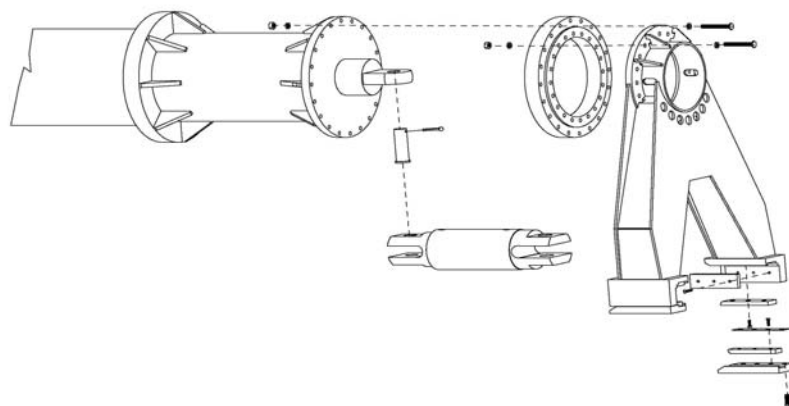
3. Counterweight Mount

Follow Step 1, Step 2 and Step 3 to mount counterweight.



4 . Kelly Bar Mount

Crowd cylinder is fully extended and rotary head is at low position; mast tilts forward; push Left Joystick forward to lower down main winch rope; connect to swivel; pull Left joystick backward and main winch winds up until kelly bar reaches the top mast; keep mast vertical, lower kelly bar through rotary head to complete kelly bar mounting.



Kelly Bar and A-frame Mount

5 . Check mast tilting degree through LCD display; adjust mast verticality.

6 . Hook up drilling tool and start drilling.

§6.3.3 Hole Opening and Casing Installation

Use reamer to open a hole after drill rig is positioned. The hole diameter should be equal to casing diameter. Use auxiliary winch to pull casing to hole location and use mast foot or drilling tool to push casing down. Casing embedded depth and casing length are based on soil condition and water table level.

§6.3.4 Drilling

1 . Short auger drilling:

Switch on SA10; push Right Joystick left and the rotary head rotates clockwise; switch on SA10 for main winch free fall; push Right Joystick left-forward for crowd force down.

Special attention : No free fall is permitted if drill rig is not in drilling process.

Drilling depth of each pass will be displayed on the LCD monitor.

1) Push Right Joystick right and the rotary head turns anticlockwise; the kelly bar and rotary head sleeve disengage.

2) Use Left Joystick for main winch up to raise kelly bar and at the same time use Right Joystick to retract crowd cylinder so that rotary head can come up.

3) Use Left Joystick to swing uppercarriage; and use Right Joystick with push button SB4 engaged for high speed spinning off.

4) Return to original position after spinning off. Use Left Joystick to lower kelly bar (**Attention: Do not use Free Fall to lower kelly bar**).

5) Repeat the above procedures.

6) Clean hole after design tip is reached.

Pay attention during drilling process:

- Keep kelly bar vertical. Keep kelly bar from wobbling.

- Drill slow at the beginning, speed up after auger goes inside soil; slow down when drilling soft-hard soil junction layer.
- Handle with care should an abnormality like high ground water level, hole collapse or hole shrinking happen.
- Do not push to drill when clean hole; do not rotate drilling tool when pulling drilling tool up.

2 . Digging bucket

- 1) Install casing. Casing imbedded length is based on soil condition and water table level.
- 2) Use stabilizer to keep hole from collapsing.
- 3) Using drilling bucket with the same procedure as augers except that the drilling bucket has an opening mechanism and the door is open when the opening mechanism hits a keeper plate on the rotary head.

3 . Core Barrel

- 1) Drilling procedure is same as auger.
- 2) Pay attention to drilling speed and pressure; keep kelly bar from jumping up and down.
- 3) Slow down drilling with low pressure before core barrel enters rock; increase speed and pressure when core barrel enters rock layer.
- 4) Slow speed with low pressure to prevent core barrel from sliding when inclined rock face is encountered. Crooked hole may break kelly bar.

§6.3.5 Drill Rig Move

Check ground condition; ground slope should be less than 5 degree. Repeat the above procedures for a new hole.

§6.3.6 LCD Monitor, Warning Icons

Check LCD Monitor and alarm warning icons. Take necessary measures when alarm beeps

Attention:

- When Alarm icons in Fig. 21, 23 and 24 turn red or flash, please check the drill rig.

- 1) When #1 icon turns red, it means the engine oil pressure is low. Do not start engine before the problem is eliminated.
- 2) When #2 icon turns red, it means the coolant temperature is too high. Slow down until the coolant temperature drops down.
- 3) When #3 icon turns red, it means the hydraulic oil temperature is too high. Slow down until hydraulic oil temperature drops down to normal temperature.
- 4) When #4 icon turns red, it means the fuel is not sufficient.
- 5) When #5 icon turns red, it means battery charger problem(or low battery). Engine can work but battery discharges quickly.
- 6) When #6 icon turns red, it means the main winch hoist has reached to the limit. Stop main winch.
- 7) When #7 icon turns red, it means the hydraulic enabling switch is OFF.
- 8) When #8 icon turns red, it means hydraulic filter needs to be replaced.

§6.3.7 Shut down

1) Lower drilling tool and kelly bar down for short time engine shut down; Boom the mast down as in Fig. 3 for long time engine shut down.

Attention: Switch off main hydraulic by pushing the Left Console up before exit the driver's cabin.

- 2) Run engine at low speed for 5 minutes to cool engine down.
- 3) Switch the ignition key to "OFF" position, pull ignition key out to switch off the main power.
- 4) Lock the cabin.

Attention:

- Stop drill rig on a flat ground;
- Clean drill rig, clean crawlers, rollers, carriers.
- Drain off any coolant which is easily to be frozen in winter.

§6.3.8 Steps to exit from drilling mode to transportation mode

- 1) Stop drill rig on a flat ground, lower rotary head to the bottom of drill mast by pushing down crowd cylinder;
- 2) Pull kelly bar up until kelly bar bracket is off the mast guide;
- 3) Let mast tilt forward until kelly bar away from mast and rotary head;
- 4) Lower main winch until kelly bar is on ground;
- 5) Use main winch and traveling mechanism to lay down kelly bar, disconnect wire rope from kelly bar;
- 6) Mast boom up vertically, swing uppercarriage left(right) 90 degree, lower mast foot down to push left(right) crawler up so that left(right) crawler can be retracted;
- 7) Swing mast back (facing front), connect triangle frame with lower drill mast;
- 8) Follow procedure in “Mast self rigging/derigging” to derig;
- 9) Use crane to fold cathead and pin cathead with mast;
- 10) Pin uppercarriage and undercarriage together;
- 11) Pin crawler cylinders;
- 12) Retract crowd cylinder or disassemble crowd cylinder;
- 13) Derigging is complete.



Pin Undercarriage

Special Attention:

- 1) **A helper is required during mast rigging/derigging.**
- 2) **Use proper length of wire rope during the mast rigging/derigging process. No wire rope overlapping is permitted in the main/aux winches.**

§7 Maintenance and Service

Periodic and proper maintenance is very important to the performance and service life of the drill rig.

§7.1 Bolt Torque

- 1) Torque

Table 7

PARTS	SPECIFICATION	THREAD	GRADE	TORQUE (N.M)
Crawler Track	GB10677-89	LS20×1.5	12.9	620
Traveling Speed Reducer	GB5782-86	M20	12.9	620
	GB5782-86	M24	12.9	1080
Swing Speed Reducer	GB5782-86	M18	8.8	240
Slewing Bearing	GB5782-86	M24	12.9	1080
Main Winch Speed Reducer	GB70-85	M16	10.9	265
	GB70-85	M20	10.9	520
	GB70-85	M24	10.9	900
Main Winch Mount	GB1228	M24	10.9	900
Aux. Winch Speed Reducer	GB70-85	M16	10.9	265
		M20	10.9	520
Aux. Winch Mount	GB5782-86	M20	10.9	520
Keeper Plate	GB5782-86	M16	10.9	265
Kelly Bar Guide Mount	GB5782-86	M16	10.9	265

2) Standard fitting torque(grade 8.8)

Table8

THREAD	M6	M8	M10	M12	M16	M18	M20	M24	M30
Torque (N.m)	10	24	44	78	190	260	370	640	1300

§7.2 Fuel

Fuel tank capacity is 400L. See Engine Manual for Fuel brand and usage.

§7.3 Hydraulic Oil

Hydraulic oil tank capacity is 750L and use FUCH, TOTAL or China #46 hydraulic oil.

§7.4 Lubrication Oil (Fat)

TABLE 9

COMPONENTS		LUBRICATION OIL(FAT)	QTY	NOTE
Traveling	Roller	HC-8HC-11(Winter)HC-14(Summer)		
	Carrier	#10(Winter), #15(Summer)		
	Idler	HC-8HC-11(Winter)HC-14(Summer)		
	Traveling Speed Reducer	CLP220LS2	Full	
	Crawler Tension Unit	Calcium Based Lubricant		
	Rotary Head	Gear	N150E(Winter) ; H200EP(Summer)	Full
2 ND Stage Reducer		VG150EP(Summer)VG100EP(Winter)	Full	
Bearing		(Lithium Based) LGMT3 LGEP2	4Kg	2/3
Winch	Reducer	CLP220LS2	Full	
	Wire rope	Calcium based grease		

Kelly Bar	Bracket	#3 Calcium based grease		
	Swivel	#3 Calcium based grease		
Swing	Slewing	#2 Calcium based grease		
	Bearing			
	Reducer	ZCLP220LS2		
Guide, Slide Frame		Calcium based grease		Surface apply
Shaft, Sleeve		Calcium based grease		
Parallelogram and Crawler Cylinder		Calcium based grease		
Engine		See Engine Manual		

§7.5 Coolant

See engine manual.

§7.6 Maintenance

1 Daily/ every 10 hours maintenance

① General check

- a) Check any leakage on fuel/oil tanks, cylinders, hoses, couplings and grease zerks;
- b) Check cooling system, leakage, hose damage and spoil built-up;
- c) Check wind shield, wiper;
- d) Check ladder, hand railing, passage;
- e) Check light.

② Check wire rope; grease on swivel; slewing bearing; kelly bar bearing.

③ Check hydraulic oil;

④ Check fuel;

⑤ Check coolant; engine oil level;

- ⑥ Check operating levers, gauges;
 - ⑦ Check drilling tool.
- 2 Weekly/every 50 working hours maintenance

- ① Check rotary head
 - a) gear box lubricant;
 - b) bolts and nuts;
 - c) speed reducer lubricant;
- ② Slewing bearing bolts and nuts;
- ③ Swing speed reducer lubricant, bolts and nuts;
- ④ Grease on pin, bearing, guide;
- ⑤ Kelly bar bearing, A-frame bolts.

3 Three Months/every 500 working hours maintenance

- ① Crawlers traveling fittings
 - a) check crawler tension unit, adjustment(after 50hours);

Use a long ruler placed on top of two carries to measure how much the crawler drops down.

Normal sagging should be 40 to 50 mm. Fill grease to increase crawler tension;

- b) check for wear and tear, strange sounds, loose bolts and nuts of traveling components;

- ② Hydraulic system check(1st check after 50hours)
 - a) change main hydraulic oil and pilot hydraulic oil filter cartridge;
 - b) change hydraulic oil tank air filter;
- ③ check guide, bolts of rotary head;
- ④ check rotary sleeve;
- ⑤ Main hydraulic oil needs to be filtered(cleaned);

4 Six month/ every 1000 working hours Maintenance

- ① change rotary head gear box lubricant;
- ② change traveling speed reducer lubricant;

- ③ change winch speed reducer lubricant;
 - ④ change rotary head speed reducer lubricant;
 - ⑤ change swing speed reducer lubricant;
 - ⑥ check battery;
- 5 Yearly/every 2000 working hours Maintenance
- ① change hydraulic oil (1st oil change after 500 working hours)
- 6 See Engine Maintenance Manual
- 7 Maintenance and service after stopping for long time
- ① clean drill rig, keep traveling components clean;
 - ② Grease hinges, guide;
 - ③ drain coolant, take battery off;
 - ④ Put drill rig in a dry place and cover with tarp;
 - ⑤ Run drill rig on a monthly basis;
- 8) Maintenance Chart(Fig.30)

Table 10

CODE	ITEM	DESCRIPTION	MAINTENANCE
1	Wire Rope	Check Wear & Tear	10h/Daily
2	Fuel	Check Full Level	10h/Daily
3	Hydraulic System	Check HYD. Level	10h/Daily
4	Coolant	Check Level	10h/Daily
5	Control Lever/Gauges	Check Lever/Gauge	10h/Daily
6	Drill Tool	Mount/Wear	10h/Daily
7	Shaft, Bearing, Slide Frame	Lubrication	50h/Weekly
	Cathead/Pulley/Bearing	Lubrication	2000h/Yearly
8	Swing Speed Reducer	Lubricant/Bolt/Nut	50h/Weekly
9	Slewing Bearing	Bolts	50h/Weekly
10	Rotary Head Guide	Bolts	50h/Weekly
11	Rotary Head Transmission Box	Lubricant/Bolts	50h/Weekly
12	Rotary Head Speed Reducer	Lubricant	50h/Weekly
13	Swivel	Lubricant/nuts	50h/Weekly
14	Air Filter	Filter Core/Replace	250h/Monthly
15	Hydraulic System	Initial Check/ Replace	50h
		Oil Filter/Air Filter	250h/Monthly
16	Slewing Ring	Lubricant	2000h/Yearly
17	Crawler Track	Initial Tension Check	50h
		Adjust Tension	250h/Monthly
18	Rotary Guide	Bolts	250h/Monthly
19	Rotary Head Sleeve	Wear & Tear	250h/Monthly
20	Kelly Bar Guide	Bolts	250h/Monthly
21	Traveling Speed Reducer	Change Oil	1000h/Six Monthes
22	Swing Speed Reducer	Periodic Change Oil	1000h/Six Monthes
23	Rotary Head Gear Box	Change Oil	1000h/Six Monthes
24	Rotary Head Speed Reducer	Change Oil	1000h/Six Monthes
25	Hydraulic System	Change Oil	500h
		Change Oil	2000h/One Year
26	Air Filter	Change	2000h/One Year
27	Roller	Change Oil	2000h/One Year
28	Carrier	Change Oil	2000h/One Year

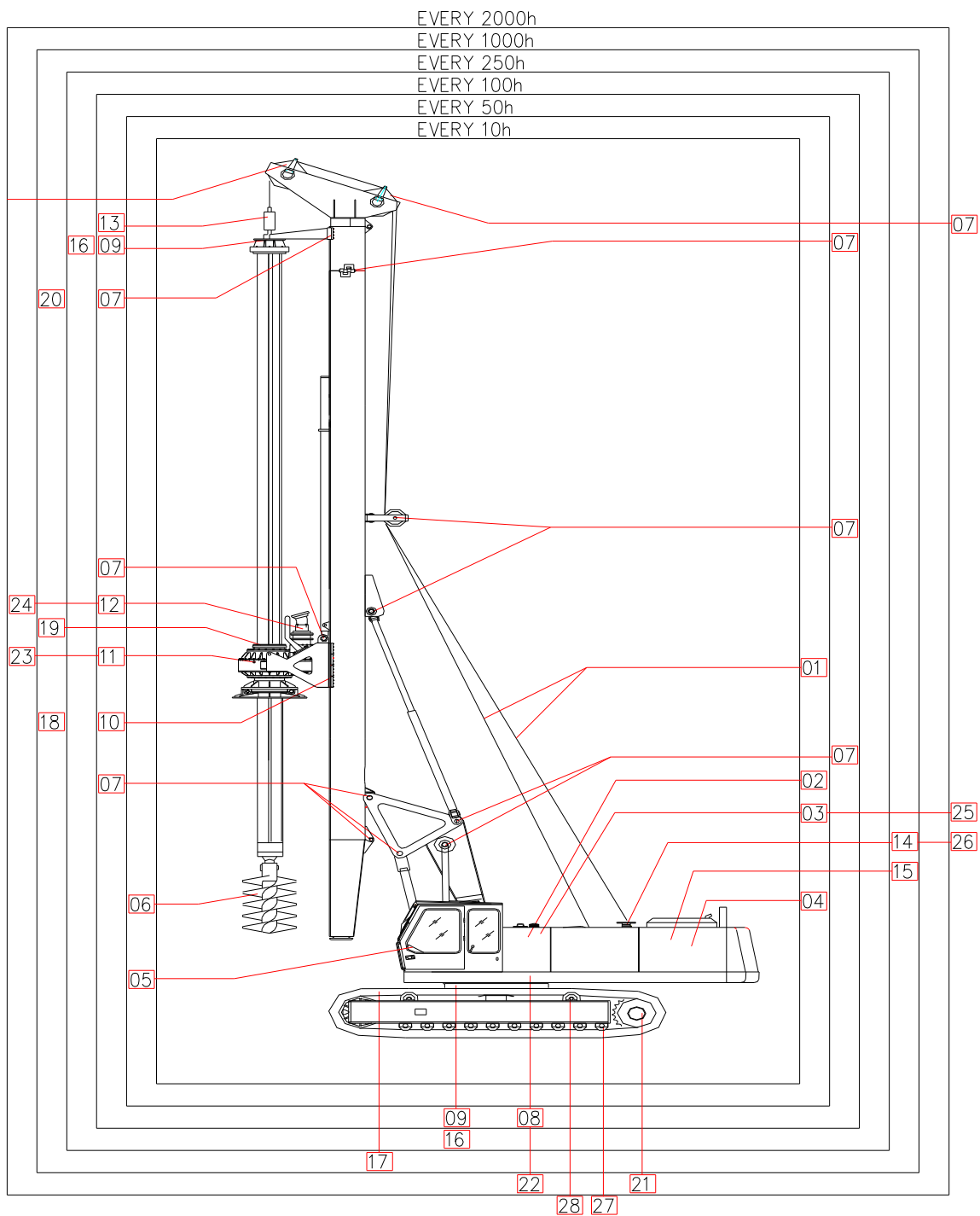


Fig. 30

§8 Transportation

§8.1 Trailer Transportation

1. See Fig. 4 for drill rig outer dimension. Dismantle drilling tool, kelly bar and crowd cylinder. Fold upper and lower drill masts up.
2. Choose right trailer.
3. Load drill rig
 - 3.1 Choose a flat ground;
 - 3.2 Block the trailer wheels;
 - 3.3 Trailer ramp should be within 15 degree;
 - 3.4 Driving wheel should be at back of drill rig, i.e. back drill rig on the trailer;
 - 3.5 Keep drill rig balance when passing through the joint between the ramp and trailer;
keep rotary head above ground by pushing up hydraulic cylinders;
4. Tie drill rig
 - 4.1 Lift hydraulic control (Left Console) to “LOCK” position;
 - 4.2 Turn ignition key to “OFF” position and pull key out from engine;
 - 4.3 Pin uppercarriage with undercarriage;
 - 4.4 Lock doors;
 - 4.5 Put wedges under crawlers, tie drill rig with cables.

§8.2 Break-down Transportation

Drill rig can be broken down for small trailer transportation, disassemble Kelly bar, drill tool, rotary head, mast and counter weight. Drill mast can be broken down into three sections.

§9 Trouble-Shooting

§9.1 Common Malfunction and Check-ups

Table 11

MALFUNCTION	CAUSES	CHECK
Engine does not start or difficult to start	Battery bad or low battery	Change /charge battery
	Starter damaged	Replace
	Poor Connection/short circuit	Repair
	See engine manual for other malfunction	
Joysticks loose/slow action	Air in hydraulic system	Check any leakage
	Hyd. Oil temperature too low, too sticky	Pre-heat engine
	Hyd. Oil bad	Replace oil
	Hyd. Pressure low	Check Hyd. System
Cylinders not working/slow	Pilot Valve	Repair
	Cyl. seals	Replace
	Overflow valve damage	Repair
Abnormal sound in rotary head	Bad Lubricant	Replace
	Low Lubricant	Re-fill
	Gear damage, worn out	Replace
	Bearing worn out	Replace
No Signal from Gauges	Gauges damaged	Repair/Replace
	Fuse Burnt	Replace
	Poor connection/short circuit	Repair

No swing/Swing	Pilot Valve Directional Valve/Break Valve Motor Swing Speed Reducer Slewing Ring	Repair Check with Sale Depart.
Engine Stops/Hyd. Arm not working/slow	No pressure/low pressure on bladder accumulator/check valve leaking	Add Nitrogen Check check valve port
One side of crawlers not moving/slow moving	Pilot Valve Directional/break valve Central Coupling Seals Motor Traveling Speed Reducer	Repair Check with Sale Dep. Change seals
High Hyd. Oil Temperature	Radiator too dirty Hyd. Components worn out, low efficiency/ overflow valve on/off too often	1.Clean 2.Check W/Sale Dept. 3.Slow down drilling speed